

# A Comparative Guide to PIKfyve Inhibitors in Cancer Cells

**Author:** BenchChem Technical Support Team. **Date:** April 2026

## Compound of Interest

Compound Name: *PIKfyve-IN-2*

Cat. No.: *B12387721*

[Get Quote](#)

For Researchers, Scientists, and Drug Development Professionals

The lipid kinase PIKfyve has emerged as a compelling therapeutic target in oncology. Its inhibition disrupts fundamental cellular processes, including endosomal and lysosomal trafficking and autophagy, leading to selective cytotoxicity in cancer cells. This guide provides an objective comparison of prominent PIKfyve inhibitors, supported by experimental data, to aid researchers in selecting the appropriate tool compounds for their studies.

## Mechanism of Action of PIKfyve Inhibitors

PIKfyve is a crucial enzyme that phosphorylates phosphatidylinositol 3-phosphate (PtdIns3P) to generate phosphatidylinositol 3,5-bisphosphate (PtdIns(3,5)P<sub>2</sub>) and phosphatidylinositol 5-phosphate (PtdIns5P). These phosphoinositides are vital for the regulation of endosome and lysosome function. By blocking PIKfyve, small molecule inhibitors disrupt the production of these lipids, leading to a cascade of cellular events including:

- **Disruption of Lysosome Homeostasis:** Inhibition of PIKfyve leads to the enlargement of lysosomes and the formation of large cytoplasmic vacuoles.<sup>[1]</sup> This is a result of impaired lysosome fission and defective fusion between autophagosomes and lysosomes (autolysosome formation).<sup>[1]</sup>

- **Blockade of Autophagy:** The impairment of autolysosome formation effectively halts the autophagy process. This is particularly detrimental to "autophagy-addicted" cancer cells that rely on this recycling pathway for survival, especially in the nutrient-poor tumor microenvironment.[1][2]
- **Induction of Cancer Cell Death:** The culmination of disrupted lysosomal function and autophagy blockade can trigger non-apoptotic cell death in cancer cells.[3]

## Comparative Efficacy of PIKfyve Inhibitors

Several small molecule inhibitors targeting PIKfyve have been developed and characterized. The following tables summarize their in vitro potency against the PIKfyve enzyme and their anti-proliferative effects in various cancer cell lines.

Inhibitor	Target	IC50 (nM)	Reference
Apilimod	PIKfyve	14	[4]
YM201636	PIKfyve	33	[5]
WX8	PIKfyve	~1 (Kd)	[1]

Table 1: In Vitro Inhibitory Potency Against PIKfyve Kinase. IC50 values represent the concentration of the inhibitor required to reduce the enzymatic activity of PIKfyve by 50%. The value for WX8 is the dissociation constant (Kd).

Inhibitor	Cancer Cell Line	Cell Type	IC50 / EC50 (µM)	Reference
Apilimod	B-cell non-Hodgkin lymphoma (various)	Lymphoma	< 0.2 (in ~73% of lines)	[6]
YM201636	Calu1	Non-small cell lung cancer	15.03 (72h)	[7]
HCC827	Non-small cell lung cancer	11.07 (72h)	[7]	
H1299	Non-small cell lung cancer	74.95 (72h)	[7]	
WX8	A375	Melanoma	~0.68 (cell death)	[8]
U2OS	Osteosarcoma	>10 (cell viability)	[1]	
ESK981	Prostate Cancer Cell Lines	Prostate Cancer	Potent growth inhibition at 0.3 µM	[9]

Table 2: Anti-proliferative Activity of PIKfyve Inhibitors in Cancer Cell Lines. IC50/EC50 values represent the concentration of the inhibitor required to inhibit cell proliferation or viability by 50%. The specific assay and incubation time are noted where available.

## Key Experimental Protocols

### Cell Viability Assay (e.g., CellTiter-Glo® Luminescent Cell Viability Assay)

This assay quantifies ATP, an indicator of metabolically active cells.

- Cell Seeding: Plate cancer cells in a 96-well plate at a density of 1,000-5,000 cells per well and incubate overnight.

- **Compound Treatment:** Add serial dilutions of the PIKfyve inhibitors to the wells. Include a vehicle control (e.g., DMSO).
- **Incubation:** Incubate the plate for a predetermined period (e.g., 72 hours).
- **Assay Procedure:** Equilibrate the plate to room temperature. Add CellTiter-Glo® reagent to each well according to the manufacturer's instructions.
- **Measurement:** Mix the contents on an orbital shaker to induce cell lysis. Measure the luminescence using a plate reader.
- **Data Analysis:** Normalize the luminescence readings to the vehicle control and plot the results to determine the IC50 value.<sup>[1]</sup>

## Autophagy Flux Assay (LC3-II Western Blotting)

This method measures the accumulation of LC3-II, a marker of autophagosomes, in the presence and absence of a lysosomal inhibitor to assess autophagic flux.

- **Cell Treatment:** Treat cells with the PIKfyve inhibitor for the desired time. For the last 2-4 hours of treatment, add a lysosomal inhibitor (e.g., Bafilomycin A1 or Chloroquine) to a subset of the wells.
- **Cell Lysis:** Wash cells with ice-cold PBS and lyse them in RIPA buffer supplemented with protease and phosphatase inhibitors.
- **Protein Quantification:** Determine the protein concentration of each lysate using a BCA assay.
- **Western Blotting:**
  - Separate equal amounts of protein on an SDS-PAGE gel.
  - Transfer the proteins to a PVDF membrane.
  - Block the membrane with 5% non-fat milk or BSA in TBST.
  - Incubate with a primary antibody against LC3.

- Wash and incubate with an HRP-conjugated secondary antibody.
- Detect the signal using an enhanced chemiluminescence (ECL) substrate.[\[10\]](#)[\[11\]](#)
- Data Analysis: Quantify the band intensity of LC3-II. Autophagic flux is determined by the difference in LC3-II levels between samples with and without the lysosomal inhibitor.[\[12\]](#)

## Signaling Pathways and Experimental Workflows

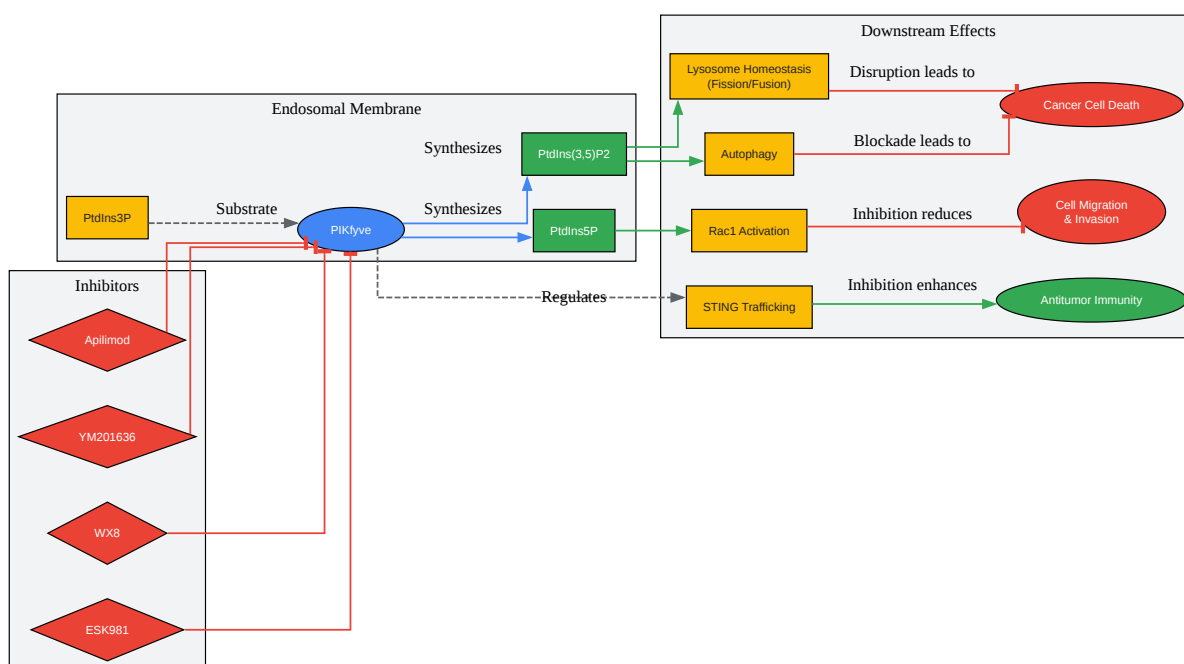

[Click to download full resolution via product page](#)

Caption: PIKfyve Signaling and Inhibition in Cancer Cells.

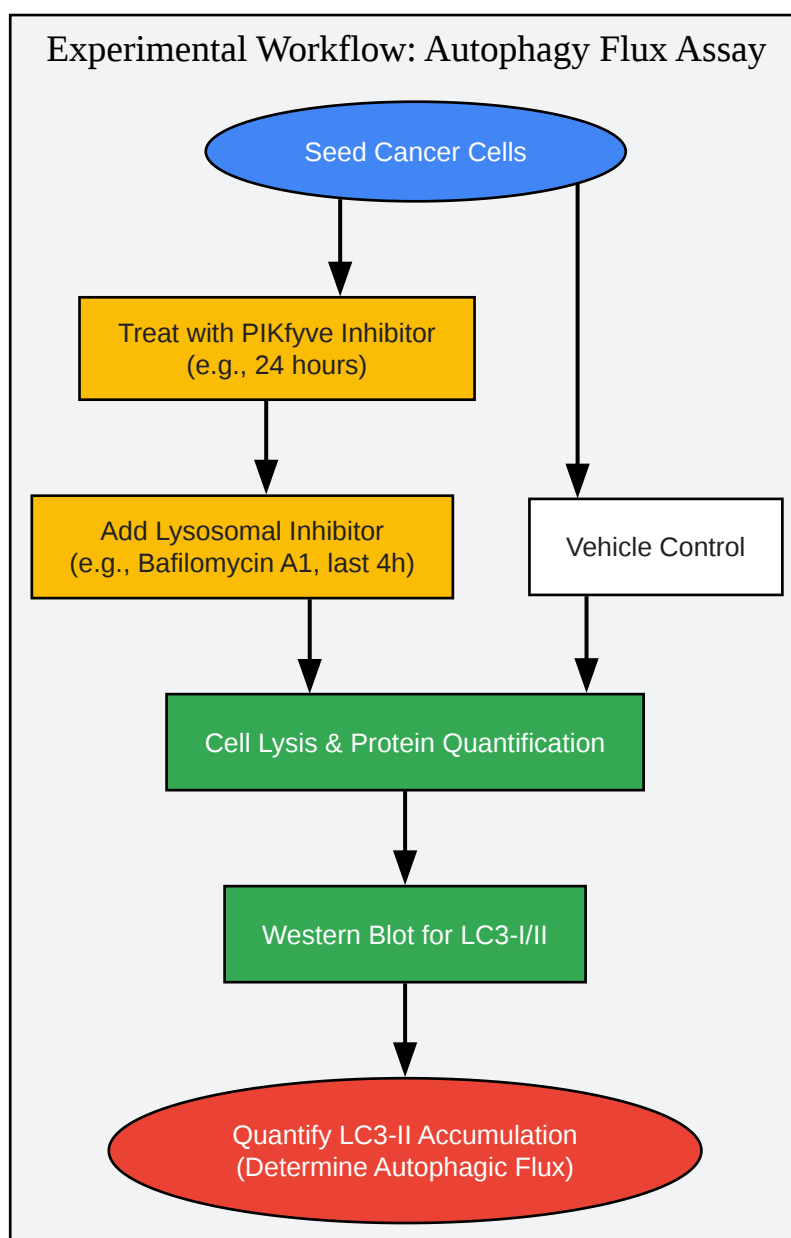

[Click to download full resolution via product page](#)

Caption: Workflow for Assessing Autophagy Flux.

#### Need Custom Synthesis?

BenchChem offers custom synthesis for rare earth carbides and specific isotopic labeling.

Email: [info@benchchem.com](mailto:info@benchchem.com) or [Request Quote Online](#).

## References

- [1. A family of PIKFYVE inhibitors with therapeutic potential against autophagy-dependent cancer cells disrupt multiple events in lysosome homeostasis - PMC \[pmc.ncbi.nlm.nih.gov\]](#)
- [2. A family of PIKFYVE inhibitors with therapeutic potential against autophagy-dependent cancer cells disrupt multiple events in lysosome homeostasis - PubMed \[pubmed.ncbi.nlm.nih.gov\]](#)
- [3. aacrjournals.org \[aacrjournals.org\]](#)
- [4. Apilimod, a candidate anticancer therapeutic, arrests not only PtdIns\(3,5\)P2 but also PtdIns5P synthesis by PIKfyve and induces bafilomycin A1-reversible aberrant endomembrane dilation - PMC \[pmc.ncbi.nlm.nih.gov\]](#)
- [5. pubs.acs.org \[pubs.acs.org\]](#)
- [6. Identification of apilimod as a first-in-class PIKfyve kinase inhibitor for treatment of B-cell non-Hodgkin lymphoma - PMC \[pmc.ncbi.nlm.nih.gov\]](#)
- [7. The effects of PIKfyve inhibitor YM201636 on claudins and malignancy potential of nonsmall cell cancer cells - PMC \[pmc.ncbi.nlm.nih.gov\]](#)
- [8. mdpi.com \[mdpi.com\]](#)
- [9. Autophagy Inhibition by Targeting PIKfyve Potentiates Response to Immune Checkpoint Blockade in Prostate Cancer - PMC \[pmc.ncbi.nlm.nih.gov\]](#)
- [10. Measuring Autophagy in Stressed Cells - PMC \[pmc.ncbi.nlm.nih.gov\]](#)
- [11. proteolysis.jp \[proteolysis.jp\]](#)
- [12. How to Measure Autophagic Flux With LC3 Protein Levels | Bio-Techne \[bio-techne.com\]](#)
- [To cite this document: BenchChem. \[A Comparative Guide to PIKfyve Inhibitors in Cancer Cells\]. BenchChem, \[2026\]. \[Online PDF\]. Available at: \[https://www.benchchem.com/product/b12387721/docs#a-comparative-guide-to-pikfyve-inhibitors-in-cancer-cells\]](#)

---

### Disclaimer & Data Validity:

The information provided in this document is for Research Use Only (RUO) and is strictly not intended for diagnostic or therapeutic procedures. While BenchChem strives to provide accurate protocols, we make no warranties, express or implied, regarding the fitness of this product for every specific experimental setup.

**Technical Support:** The protocols provided are for reference purposes. Unsure if this reagent suits your experiment?

**Need Industrial/Bulk Grade?** [Request Custom Synthesis Quote](#)

## BenchChem

Our mission is to be the trusted global source of essential and advanced chemicals, empowering scientists and researchers to drive progress in science and industry.

### Contact

Address: 3281 E Guasti Rd  
Ontario, CA 91761, United States  
Phone: (601) 213-4426  
Email: [info@benchchem.com](mailto:info@benchchem.com)

[Contact our Ph.D. Support Team for a compatibility check](#)