

Technical Support Center: Troubleshooting SJF-0661 Control Experiments

Author: BenchChem Technical Support Team. **Date:** April 2026

Compound of Interest

Compound Name: SJF-0661
Cat. No.: B12386536

[Get Quote](#)

This technical support center provides guidance for researchers, scientists, and drug development professionals encountering unexpected results with the **SJF-0661** control compound. The following troubleshooting guides and frequently asked questions (FAQs) are designed to address specific issues that may arise during your experiments.

Frequently Asked Questions (FAQs)

Q1: I am observing degradation of BRAF protein when using **SJF-0661**, which is supposed to be an inactive control. What could be the reason for this?

A1: This is an unexpected result, as **SJF-0661** is designed to be the negative control for the BRAF-targeting PROTAC SJF-0628. **SJF-0661** possesses an identical warhead and linker to SJF-0628 but contains an inverted hydroxyl group in its VHL ligand.^[1] This modification prevents its engagement with the VHL E3 ubiquitin ligase, thereby inhibiting the ubiquitination and subsequent degradation of the BRAF protein.^[1]

Potential causes for observing BRAF degradation with **SJF-0661** include:

- Compound Mix-Up: The most common reason is a simple mix-up of vials containing **SJF-0661** and the active compound, SJF-0628. We recommend clearly labeling all tubes and

maintaining stringent laboratory notebook practices.

- Contamination: The **SJF-0661** stock solution may have been contaminated with the active SJF-0628 compound. Prepare fresh stock solutions from the original powders to rule out this possibility.
- Off-Target Effects at High Concentrations: While designed as a negative control, exceptionally high concentrations of any compound can sometimes lead to non-specific or off-target effects. It is crucial to use **SJF-0661** at the same concentration as the active PROTAC.
- Experimental Artifacts: Ensure that the observed protein degradation is not an artifact of the experimental procedure. Include appropriate vehicle controls (e.g., DMSO) and untreated samples in your experiments.

To troubleshoot this issue, we recommend performing a dose-response experiment comparing SJF-0628 and **SJF-0661**, analyzing BRAF protein levels via Western Blot.

Q2: My results show no difference between the vehicle control and the **SJF-0661** treated group, but the active compound (SJF-0628) is also not showing any BRAF degradation. What should I do?

A2: If both the negative control (**SJF-0661**) and the active compound (SJF-0628) are not inducing BRAF degradation, it is likely that there is an issue with the experimental setup or the reagents.

Here are some troubleshooting steps:

- Cell Line Sensitivity: Confirm that the cell line you are using expresses a form of BRAF that is susceptible to degradation by SJF-0628.
- Compound Integrity: Ensure that the active compound, SJF-0628, has not degraded. Check the storage conditions and consider using a fresh vial.
- Treatment Time and Concentration: The concentration of the PROTAC and the duration of the treatment may not be optimal. Perform a time-course and dose-response experiment to determine the optimal conditions for BRAF degradation with SJF-0628.

- **Reagent and Protocol Verification:** Review your experimental protocol, including cell seeding density, lysis buffer composition, and Western Blotting procedure. Ensure all reagents are fresh and properly prepared.

Q3: Can **SJF-0661** be used to study cellular phenotypes unrelated to BRAF degradation?

A3: While **SJF-0661** is primarily designed as a negative control for BRAF degradation studies, it can be a useful tool to investigate potential off-target effects of the chemical scaffold shared with SJF-0628. If you observe a cellular phenotype with SJF-0628 that is independent of BRAF degradation, treating cells with **SJF-0661** at the same concentration can help determine if this phenotype is due to the engagement of other cellular targets by the warhead or linker components.

Experimental Protocols

Western Blotting for BRAF Degradation

This protocol is designed to assess the levels of BRAF protein in cell lysates following treatment with SJF-0628 and **SJF-0661**.

- **Cell Seeding:** Seed cells in 6-well plates at a density that will result in 70-80% confluency at the time of harvest.
- **Compound Treatment:** The following day, treat the cells with the desired concentrations of SJF-0628, **SJF-0661**, or vehicle control (e.g., DMSO) for the specified duration (e.g., 24 hours).
- **Cell Lysis:**
 - Wash the cells once with ice-cold PBS.
 - Add 100 μ L of ice-cold RIPA buffer supplemented with protease and phosphatase inhibitors to each well.
 - Scrape the cells and transfer the lysate to a pre-chilled microcentrifuge tube.
 - Incubate on ice for 30 minutes, vortexing every 10 minutes.

- Centrifuge at 14,000 rpm for 15 minutes at 4°C.
- Transfer the supernatant to a new tube.
- Protein Quantification: Determine the protein concentration of each lysate using a BCA protein assay.
- Sample Preparation: Normalize the protein concentrations and prepare samples for SDS-PAGE by adding Laemmli sample buffer and boiling at 95°C for 5 minutes.
- SDS-PAGE and Western Blotting:
 - Load equal amounts of protein onto a polyacrylamide gel.
 - Separate the proteins by electrophoresis.
 - Transfer the proteins to a PVDF membrane.
 - Block the membrane with 5% non-fat milk or BSA in TBST for 1 hour at room temperature.
 - Incubate the membrane with a primary antibody against BRAF overnight at 4°C.
 - Wash the membrane three times with TBST.
 - Incubate with an appropriate HRP-conjugated secondary antibody for 1 hour at room temperature.
 - Wash the membrane three times with TBST.
 - Visualize the protein bands using an enhanced chemiluminescence (ECL) substrate and an imaging system.
 - Use a loading control, such as β -actin or GAPDH, to ensure equal protein loading.

Co-Immunoprecipitation (Co-IP) to Assess VHL Engagement

This protocol is used to determine if SJF-0628, but not **SJF-0661**, can induce the interaction between BRAF and VHL.

- Cell Treatment and Lysis: Treat cells with SJF-0628, **SJF-0661**, or vehicle control as described above. Lyse the cells in a non-denaturing lysis buffer (e.g., Triton X-100 based buffer).
- Immunoprecipitation:
 - Pre-clear the lysates by incubating with protein A/G agarose beads for 1 hour at 4°C.
 - Incubate the pre-cleared lysates with an antibody against VHL overnight at 4°C.
 - Add protein A/G agarose beads and incubate for 2-4 hours at 4°C to capture the antibody-protein complexes.
 - Wash the beads three to five times with lysis buffer.
- Elution and Western Blotting:
 - Elute the immunoprecipitated proteins from the beads by boiling in Laemmli sample buffer.
 - Analyze the eluted proteins by Western Blotting using antibodies against BRAF and VHL. An increased amount of BRAF in the VHL immunoprecipitate from SJF-0628-treated cells would indicate PROTAC-induced complex formation.

Data Presentation

Table 1: Representative BRAF Protein Levels Following Treatment with SJF-0628 and **SJF-0661**

Compound	Concentration (nM)	BRAF Protein Level (% of Vehicle)
Vehicle (DMSO)	-	100%
SJF-0628	1	85%
SJF-0628	10	50%
SJF-0628	100	15%
SJF-0661	1	98%
SJF-0661	10	95%
SJF-0661	100	92%

Table 2: Representative Co-Immunoprecipitation Results for VHL-BRAF Interaction

Treatment	VHL IP: BRAF Signal (Arbitrary Units)
Vehicle (DMSO)	5
SJF-0628 (100 nM)	85
SJF-0661 (100 nM)	7

Visualizations

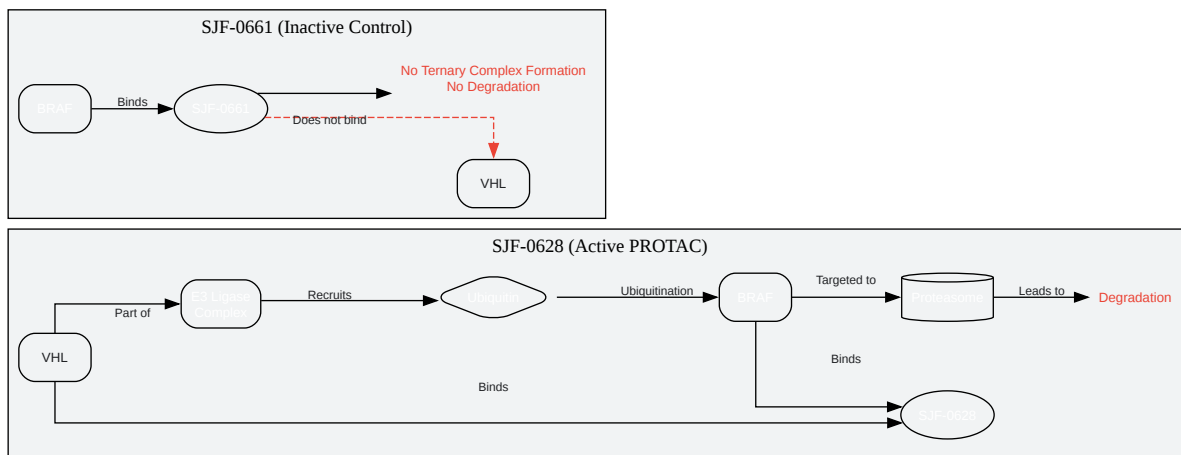

[Click to download full resolution via product page](#)

Caption: Mechanism of action for SJF-0628 vs. the inactive control **SJF-0661**.

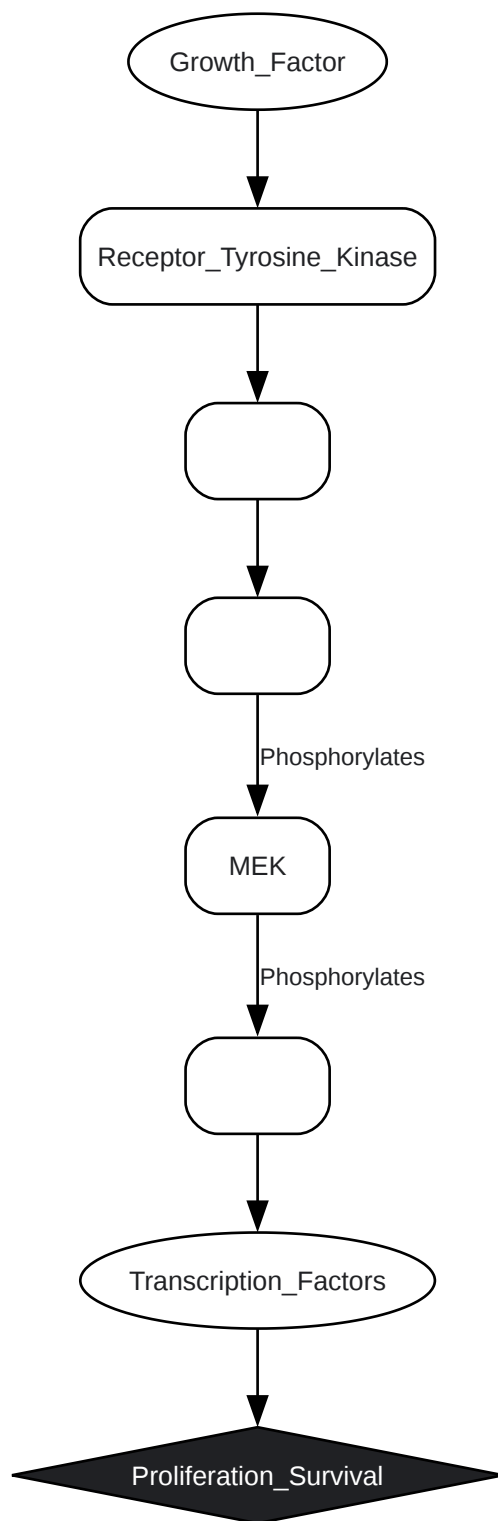

[Click to download full resolution via product page](#)

Caption: Simplified BRAF signaling pathway.

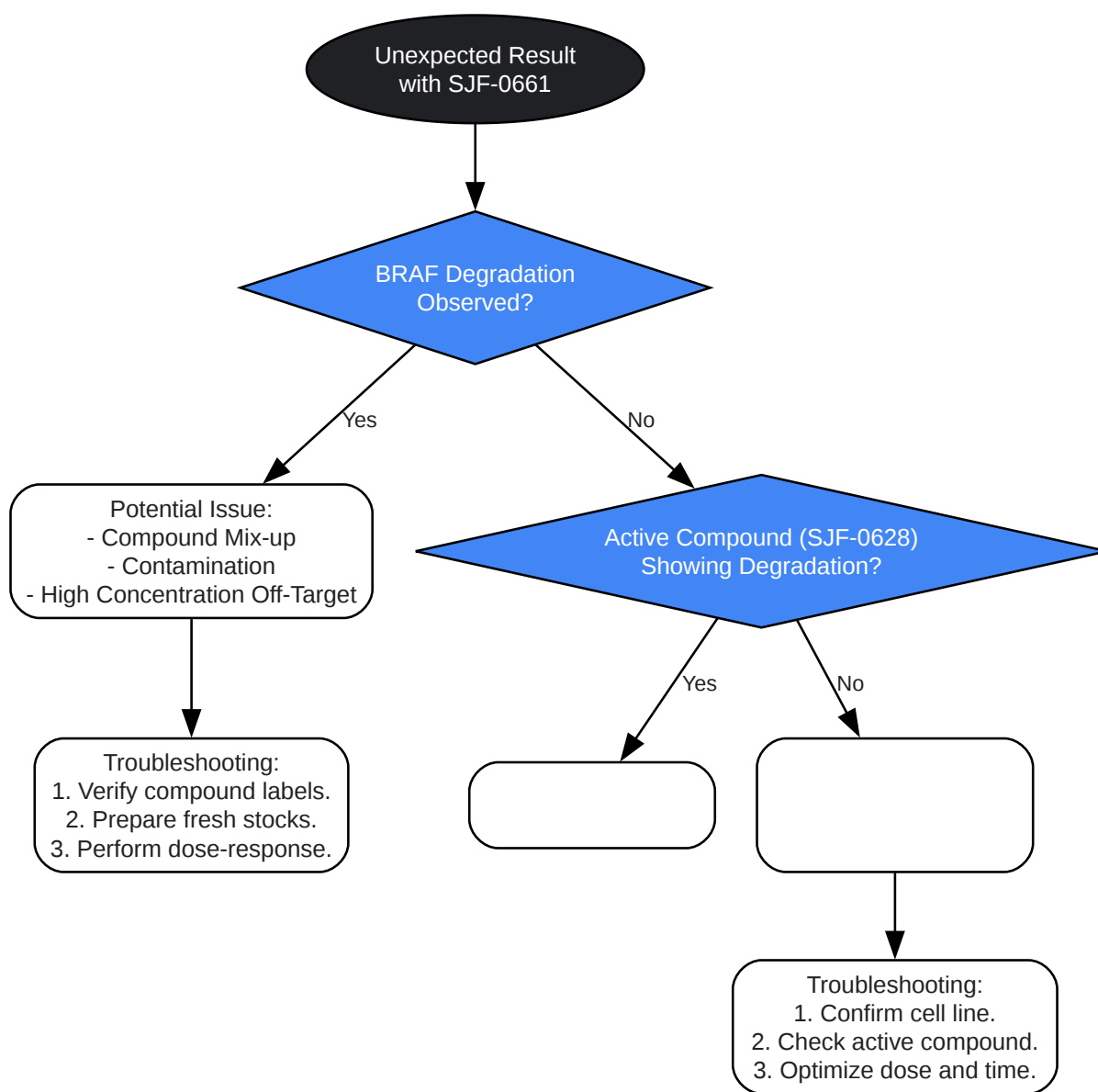

[Click to download full resolution via product page](#)

Caption: Troubleshooting workflow for unexpected results with **SJF-0661**.

Need Custom Synthesis?

BenchChem offers custom synthesis for rare earth carbides and specific isotopic labeling.

Email: info@benchchem.com or [Request Quote Online](#).

References

- [1. medkoo.com \[medkoo.com\]](https://www.medkoo.com)
- To cite this document: BenchChem. [Technical Support Center: Troubleshooting SJF-0661 Control Experiments]. BenchChem, [2026]. [Online PDF]. Available at: [<https://www.benchchem.com/product/b12386536/docs#technical-support-center-troubleshooting-sjf-0661-control-experiments>]

Disclaimer & Data Validity:

The information provided in this document is for Research Use Only (RUO) and is strictly not intended for diagnostic or therapeutic procedures. While BenchChem strives to provide accurate protocols, we make no warranties, express or implied, regarding the fitness of this product for every specific experimental setup.

Technical Support: The protocols provided are for reference purposes. Unsure if this reagent suits your experiment?

Need Industrial/Bulk Grade? [Request Custom Synthesis Quote](#)

BenchChem

Our mission is to be the trusted global source of essential and advanced chemicals, empowering scientists and researchers to drive progress in science and industry.

Contact

Address: 3281 E Guasti Rd
Ontario, CA 91761, United States
Phone: (601) 213-4426
Email: info@benchchem.com

[Contact our Ph.D. Support Team for a compatibility check](#)