

Comparative Analysis of SJF-0661 Kinase Selectivity: A Guide for Researchers

Author: BenchChem Technical Support Team. **Date:** April 2026

Compound of Interest

Compound Name: SJF-0661
Cat. No.: B12386536

[Get Quote](#)

For researchers, scientists, and drug development professionals, understanding the selectivity of a kinase inhibitor is paramount to predicting its efficacy and potential off-target effects. This guide provides a comparative framework for evaluating the cross-reactivity of **SJF-0661**, a BRAF-targeting Proteolysis Targeting Chimera (PROTAC), against other kinases.

SJF-0661 is designed as a negative control for its counterpart, SJF-0628. While it contains the same "warhead" to bind to the BRAF kinase, it possesses an altered VHL ligand, rendering it incapable of inducing ubiquitination and subsequent degradation of its target.^[1] This makes the analysis of its direct kinase interactions crucial for interpreting experimental results. A comprehensive kinase selectivity profile, typically generated through assays like KINOMEscan®, provides a detailed map of a compound's binding affinities across the human kinome.

Understanding Kinase Cross-Reactivity

Protein kinases share a conserved ATP binding pocket, which is the target for many small molecule inhibitors. This structural similarity can lead to inhibitors binding to unintended kinases, known as off-target effects. These off-target interactions can result in unexpected

cellular responses, toxicity, or even therapeutic benefits. Therefore, a thorough assessment of an inhibitor's selectivity is a critical step in its development and characterization.

Hypothetical Kinase Selectivity Profile of a BRAF Inhibitor

While specific experimental data for the kinase selectivity of **SJF-0661** is not publicly available, the following table illustrates the type of data generated from a comprehensive kinase screen. It presents a hypothetical comparison between a highly selective BRAF inhibitor and a less selective counterpart, demonstrating how selectivity is quantified and reported. The data is typically presented as the dissociation constant (Kd) or the percentage of control, where a lower Kd value indicates a stronger binding affinity.

Kinase Target	Selective BRAF Inhibitor (Hypothetical Kd in nM)	Non-Selective BRAF Inhibitor (Hypothetical Kd in nM)	Kinase Family
BRAF	1.5	5.2	TKL
BRAF-V600E	0.8	2.1	TKL
ARAF	5,500	85	TKL
RAF1 (CRAF)	8,200	110	TKL
MAP2K1 (MEK1)	>10,000	1,500	STE
MAP2K2 (MEK2)	>10,000	1,800	STE
SRC	>10,000	250	TK
LCK	>10,000	300	TK
YES1	>10,000	280	TK
AURKA	9,800	450	STE
AURKB	>10,000	500	STE
CDK2	>10,000	2,200	CMGC

This table presents hypothetical data for illustrative purposes.

Experimental Protocols: Kinase Selectivity Profiling via KINOMEScan®

The KINOMEScan® platform is a widely used competition binding assay to determine the interaction of a test compound with a large panel of kinases.

Principle: The assay measures the ability of a test compound to compete with an immobilized, active-site-directed ligand for binding to a DNA-tagged kinase. The amount of kinase bound to the immobilized ligand is quantified using quantitative PCR (qPCR) of the DNA tag. A lower amount of bound kinase in the presence of the test compound indicates a stronger interaction.

Detailed Protocol:

- **Preparation of Affinity Beads:** Streptavidin-coated magnetic beads are treated with a biotinylated small molecule ligand to create an affinity resin. The beads are then blocked to minimize non-specific binding.
- **Binding Reaction:** The DNA-tagged kinase, the liganded affinity beads, and the test compound (**SJF-0661** in this case) are combined in a binding buffer. The reaction is typically performed in a multi-well plate format. For determining the dissociation constant (Kd), the test compound is prepared in an 11-point, 3-fold serial dilution.
- **Incubation:** The assay plates are incubated for one hour at room temperature with shaking to allow the binding reaction to reach equilibrium.
- **Washing:** The affinity beads are washed to remove any unbound protein.
- **Elution:** The bound kinase is eluted from the beads.
- **Quantification:** The concentration of the eluted kinase is measured by qPCR using the DNA tag as a template. The results are compared to a DMSO control to determine the percentage of kinase binding that was inhibited by the test compound.
- **Data Analysis:** The dissociation constants (Kd) are calculated from the dose-response curves of the test compound.

Visualizing Biological Context and Experimental Workflow

To better understand the implications of BRAF inhibition and the process of selectivity profiling, the following diagrams illustrate the BRAF signaling pathway and the KINOMEScan® experimental workflow.

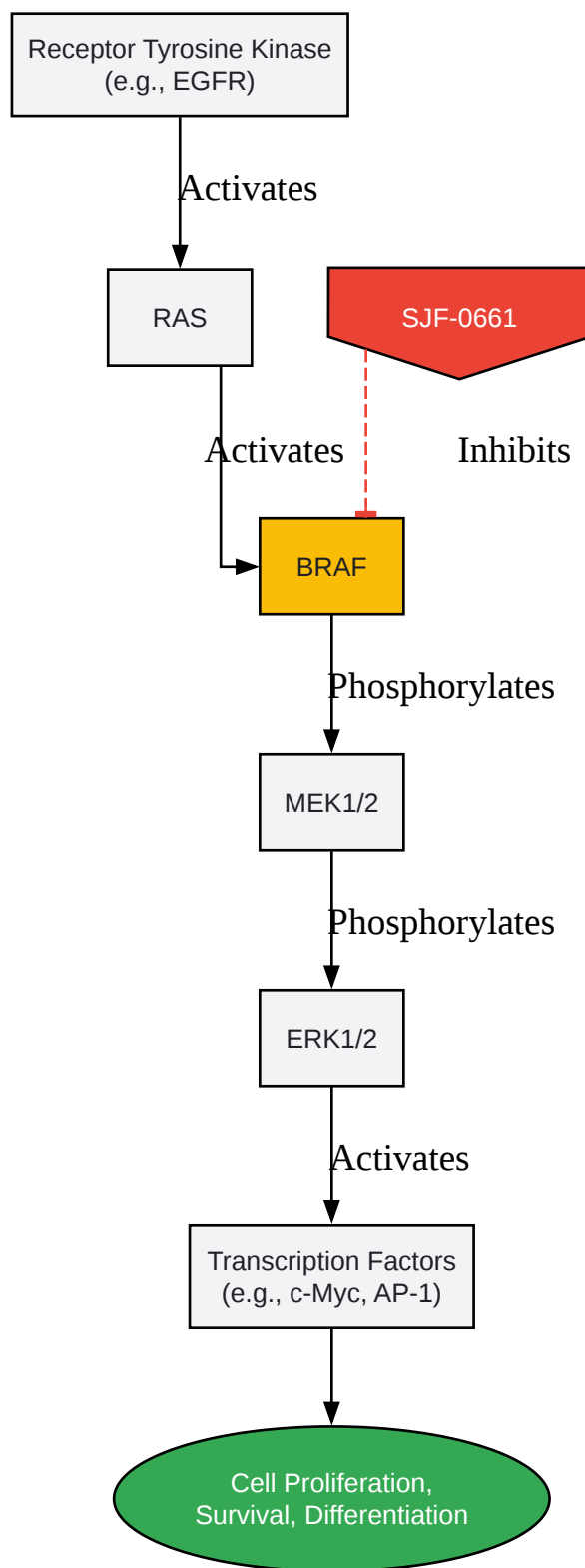

[Click to download full resolution via product page](#)

BRAF Signaling Pathway and the Point of Inhibition by **SJF-0661**.

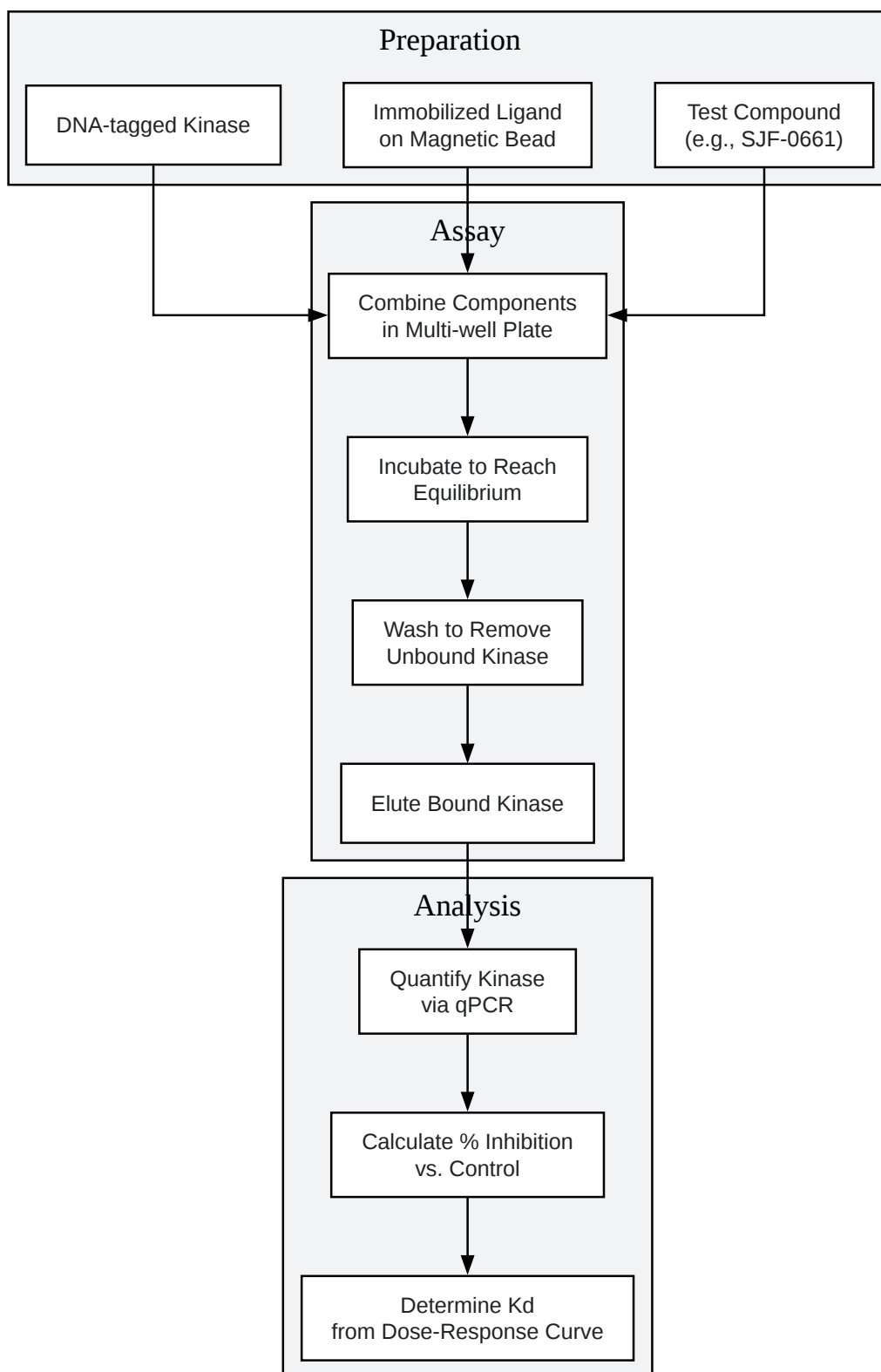

[Click to download full resolution via product page](#)

Need Custom Synthesis?

BenchChem offers custom synthesis for rare earth carbides and specific isotopic labeling.

Email: info@benchchem.com or [Request Quote Online](#).

References

- 1. [mdpi.com](https://www.mdpi.com) [mdpi.com]
- To cite this document: BenchChem. [Comparative Analysis of SJF-0661 Kinase Selectivity: A Guide for Researchers]. BenchChem, [2026]. [Online PDF]. Available at: [<https://www.benchchem.com/product/b12386536/docs#comparative-analysis-of-sjf-0661-kinase-selectivity-a-guide-for-researchers>]

Disclaimer & Data Validity:

The information provided in this document is for Research Use Only (RUO) and is strictly not intended for diagnostic or therapeutic procedures. While BenchChem strives to provide accurate protocols, we make no warranties, express or implied, regarding the fitness of this product for every specific experimental setup.

Technical Support: The protocols provided are for reference purposes. Unsure if this reagent suits your experiment?

Need Industrial/Bulk Grade? [Request Custom Synthesis Quote](#)

BenchChem

Our mission is to be the trusted global source of essential and advanced chemicals, empowering scientists and researchers to drive progress in science and industry.

Contact

Address: 3281 E Guasti Rd

Ontario, CA 91761, United States

Phone: (601) 213-4426

Email: info@benchchem.com

Contact our Ph.D. Support Team for a compatibility check