

Application Notes and Protocols for the Characterization of TAM558 Intermediate-2

Author: BenchChem Technical Support Team. **Date:** April 2026

Compound of Interest

Compound Name: TAM558 intermediate-2

Cat. No.: B12386905

[Get Quote](#)

These application notes provide a comprehensive guide for the analytical characterization of **TAM558 Intermediate-2**, a key precursor in the synthesis of the investigational drug TAM558. The following protocols are designed for researchers, scientists, and drug development professionals to ensure the identity, purity, and quality of this critical intermediate.

High-Performance Liquid Chromatography (HPLC) for Purity Assessment

Application: This method is designed to determine the purity of **TAM558 Intermediate-2** and to quantify any process-related impurities. A reversed-phase HPLC method is employed for optimal separation of the intermediate from potential by-products.

Experimental Protocol

- Instrumentation: A standard HPLC system equipped with a UV detector, autosampler, and column oven.
- Column: C18, 4.6 x 150 mm, 5 µm particle size.
- Mobile Phase A: 0.1% Formic Acid in Water.

- Mobile Phase B: 0.1% Formic Acid in Acetonitrile.
- Gradient Elution:
 - 0-5 min: 5% B
 - 5-25 min: 5% to 95% B
 - 25-30 min: 95% B
 - 30.1-35 min: 5% B (re-equilibration)
- Flow Rate: 1.0 mL/min.
- Column Temperature: 30°C.
- Detection Wavelength: 254 nm.
- Injection Volume: 10 µL.
- Sample Preparation: Accurately weigh and dissolve 1 mg of **TAM558 Intermediate-2** in 1 mL of a 50:50 mixture of Mobile Phase A and B.

Data Presentation

Parameter	Specification	Result
Retention Time (RT)	Report in minutes	15.2 min
Purity (Area %)	≥ 98.0%	99.1%
Largest Impurity (Area %)	≤ 0.5%	0.3% at 12.8 min
Total Impurities (Area %)	≤ 2.0%	0.9%

Experimental Workflow

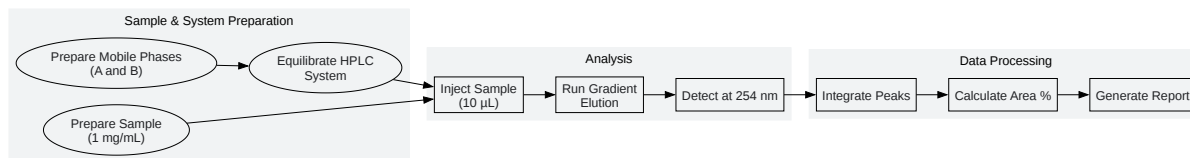

[Click to download full resolution via product page](#)

Caption: HPLC Purity Analysis Workflow for **TAM558 Intermediate-2**.

Liquid Chromatography-Mass Spectrometry (LC-MS) for Identity Confirmation

Application: This protocol confirms the molecular identity of **TAM558 Intermediate-2** by determining its molecular weight. This method is also crucial for identifying and characterizing unknown impurities.

Experimental Protocol

- Instrumentation: An LC-MS system with an electrospray ionization (ESI) source.
- LC Conditions: Use the same HPLC conditions as described in the purity assessment protocol.
- MS Detector: Quadrupole or Time-of-Flight (TOF) mass analyzer.
- Ionization Mode: Positive ESI.
- Mass Range: 100-1000 m/z.
- Capillary Voltage: 3.5 kV.

- Drying Gas Temperature: 325°C.
- Sample Preparation: Dilute the sample prepared for HPLC analysis 1:10 with the initial mobile phase composition.

Data Presentation

Parameter	Theoretical Value	Observed Value	Ion Adduct
Molecular Weight	342.15 g/mol	343.16	[M+H] ⁺
Impurity 1 MW	N/A	357.14	[M+H] ⁺

Logical Workflow for Identity Confirmation

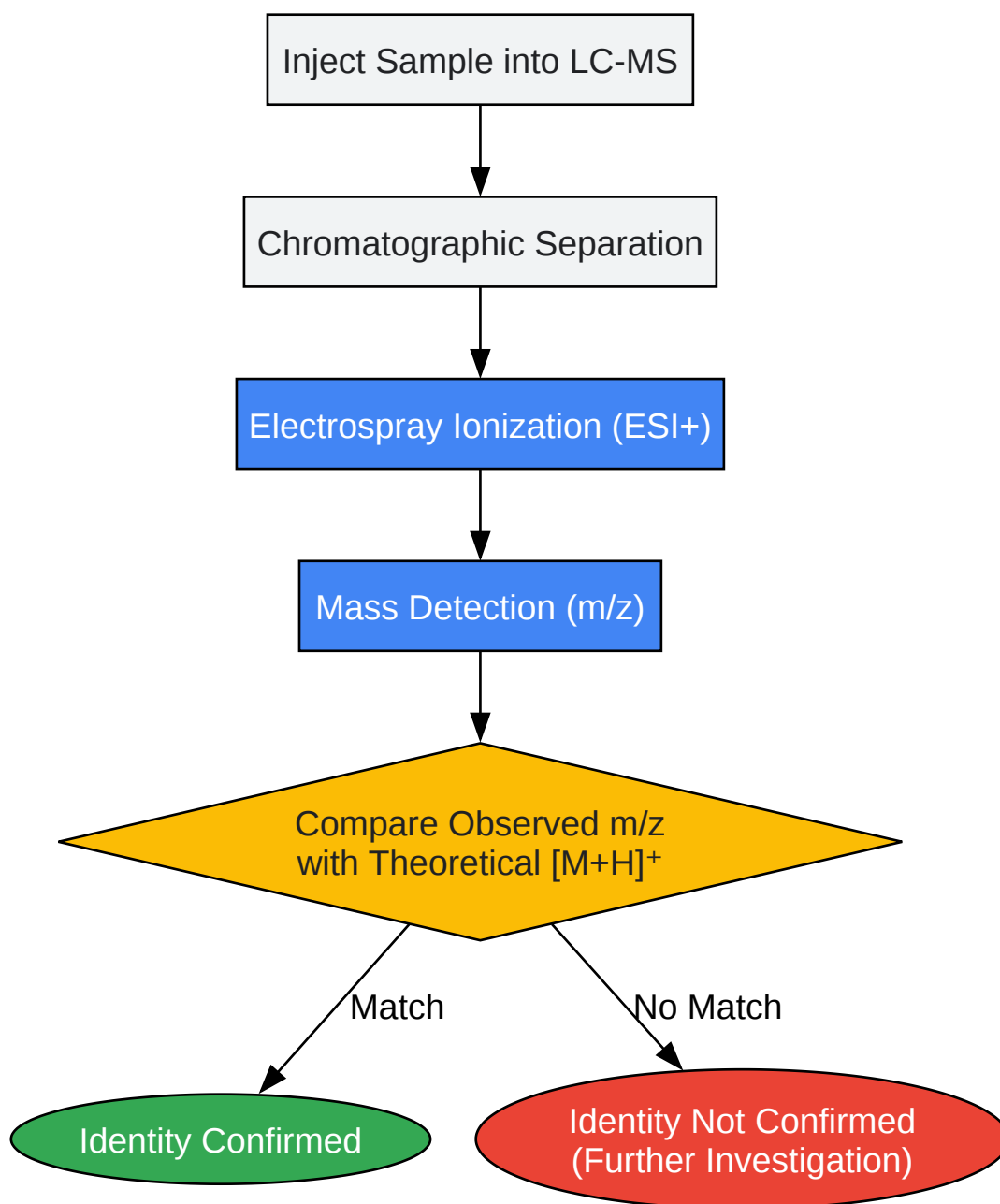

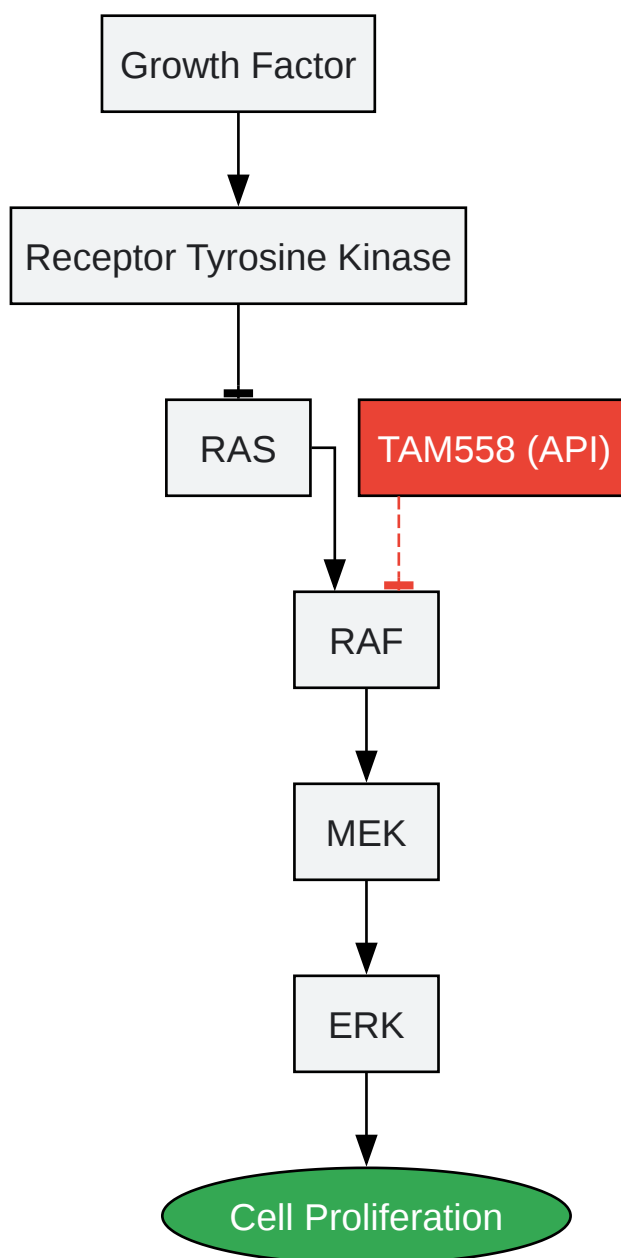

[Click to download full resolution via product page](#)

- To cite this document: BenchChem. [Application Notes and Protocols for the Characterization of TAM558 Intermediate-2]. BenchChem, [2026]. [Online PDF]. Available at: [\[https://www.benchchem.com/product/b12386905/docs#application-notes-and-protocols-for-the-characterization-of-tam558-intermediate-2\]](https://www.benchchem.com/product/b12386905/docs#application-notes-and-protocols-for-the-characterization-of-tam558-intermediate-2)

Disclaimer & Data Validity:

The information provided in this document is for Research Use Only (RUO) and is strictly not intended for diagnostic or therapeutic procedures. While BenchChem strives to provide accurate protocols, we make no warranties, express or implied, regarding the fitness of this product for every specific experimental setup.

Technical Support: The protocols provided are for reference purposes. Unsure if this reagent suits your experiment?

Need Industrial/Bulk Grade? [Request Custom Synthesis Quote](#)

BenchChem

Our mission is to be the trusted global source of essential and advanced chemicals, empowering scientists and researchers to drive progress in science and industry.

Contact

Address: 3281 E Guasti Rd
Ontario, CA 91761, United States
Phone: (601) 213-4426
Email: info@benchchem.com

[Contact our Ph.D. Support Team for a compatibility check](#)