

The Steric Zipper: A Linchpin in GNNQQNY Assembly and Amyloid Formation

Author: BenchChem Technical Support Team. **Date:** December 2025

Compound of Interest

Compound Name: *Amyloid-Forming peptide*
GNNQQNY

Cat. No.: B12385149

[Get Quote](#)

An In-depth Technical Guide for Researchers, Scientists, and Drug Development Professionals

The aggregation of proteins into amyloid fibrils is a hallmark of numerous neurodegenerative diseases. Understanding the molecular mechanisms driving this process is paramount for the development of effective therapeutic interventions. The GNNQQNY peptide, a seven-residue segment from the yeast prion protein Sup35, has emerged as a pivotal model system for studying amyloid assembly. Its propensity to form highly ordered, self-propagating amyloid fibrils is largely attributed to a specific structural motif known as the "steric zipper." This technical guide provides a comprehensive overview of the role of the steric zipper in GNNQQNY assembly, integrating quantitative data, detailed experimental protocols, and visual representations of the underlying processes.

The Core Concept: The GNNQQNY Steric Zipper

The GNNQQNY peptide self-assembles into β -sheets, which then stack to form protofilaments and mature amyloid fibrils. The stability of this architecture is critically dependent on the formation of a "steric zipper" at the interface between two β -sheets. This structure is characterized by the tight interdigitation of side chains from opposing sheets, creating a dry, complementary interface that excludes water molecules.[1][2] In the case of GNNQQNY, the side chains of asparagine (N) and glutamine (Q) residues play a crucial role in forming a network of hydrogen bonds that "zip" the sheets together.[3][4] This self-complementary nature

of the GNNQQNY sequence is a key determinant of its high propensity for amyloid formation.
[1]

The formation of the steric zipper is a critical step in the nucleation-dependent aggregation of GNNQQNY.[3][5] This process begins with a lag phase, where soluble monomers gradually form small, unstable oligomers. Once a critical nucleus with a stable steric zipper is formed, fibril elongation proceeds rapidly.[5][6]

Quantitative Insights into GNNQQNY Assembly

The study of GNNQQNY aggregation has yielded valuable quantitative data that helps to delineate the thermodynamics, kinetics, and structural features of amyloid formation.

Thermodynamic Parameters

Molecular dynamics simulations have provided insights into the energy landscape of GNNQQNY assembly. The formation of dimers from monomers is a rapid process, and these dimers are kinetically stable at room temperature.[7][8] The in-register parallel β -sheet conformation, which is characteristic of the amyloid state, is stabilized by a combination of hydrogen bonding and hydrophobic interactions.[7]

Parameter	Value/Observation	Method	Reference
Dimer Stability	Kinetically stable against dissociation at room temperature.	Replica Exchange Molecular Dynamics	[7][8]
Dominant Dimer Conformation	In-register parallel, off-register parallel, and antiparallel β -sheets are stable.	Replica Exchange Molecular Dynamics	[7][8]
Driving Forces for Aggregation	Primarily hydrogen bond formation, leading to early β -sheet formation.	Replica-Exchange Molecular Dynamics	[9]

Kinetic Parameters

The aggregation of GNNQQNY follows nucleation-dependent kinetics, characterized by a concentration-dependent lag phase.[3][10] The critical nucleus size has been estimated to be between three to seven monomers.[3][4][5]

Parameter	Value/Observation	Method	Reference
Aggregation Mechanism	Nucleation-dependent, with a concentration-dependent lag phase.	Turbidity Assays, RP-HPLC-based sedimentation assay	[3][10]
Critical Nucleus Size	~3-4 peptides	Molecular Dynamics Simulations	[4]
Critical Nucleus Size	~7 monomers	Nucleation kinetics analysis (pH 7.4, 37°C)	[3]
Critical Nucleus Size	4-5 monomers (at 280 K), 5-6 monomers (at 300 K)	Molecular Dynamics Simulations	[5]

Structural Parameters

X-ray crystallography and solid-state NMR have provided high-resolution structural details of GNNQQNY fibrils, confirming the steric zipper architecture.[2][11][12]

Parameter	Value/Observation	Method	Reference
Inter-sheet distance	~10 Å	X-ray Diffraction	[10]
Inter-strand distance (within a β -sheet)	~4.7 Å	X-ray Diffraction	[10]
β -sheet conformation	Parallel, in-register	X-ray Crystallography, Solid-State NMR	[2][11]
Fibril Morphology	Long, unbranched fibrils	Electron Microscopy	[10][13]

Experimental Protocols for Studying GNNQQNY Assembly

A variety of experimental techniques are employed to investigate the structure and assembly of GNNQQNY fibrils.

GNNQQNY Peptide Preparation and Fibril Formation

A reproducible protocol for generating monomeric GNNQQNY is crucial for kinetic studies.

- **Solubilization:** Dissolve lyophilized GNNQQNY peptide in deionized water to a desired concentration. To ensure a monomeric state, the pH of the solution is reduced to 2.0 using HCl.[3]
- **Removal of Pre-aggregated Species:** Centrifuge the acidic peptide solution at high speed (e.g., 100,000 x g) for a specified time to pellet any residual insoluble aggregates.[3]
- **Initiation of Fibrillation:** Adjust the pH of the supernatant to 7.2 or 7.4 using NaOH to trigger the aggregation process.[3]
- **Incubation:** Incubate the peptide solution at a controlled temperature (e.g., 37°C) with or without agitation. Fibril formation can be monitored over time.[3]

Thioflavin T (ThT) Fluorescence Assay

ThT is a fluorescent dye that exhibits enhanced fluorescence upon binding to amyloid fibrils, making it a standard tool for monitoring aggregation kinetics.

- **Prepare ThT Stock Solution:** Dissolve Thioflavin T in a suitable buffer (e.g., Tris buffer, pH 7.4) to a final concentration of 10 μ M.
- **Assay:** At various time points during the GNNQQNY incubation, take an aliquot of the peptide solution and add it to the ThT solution in a quartz cuvette.
- **Fluorescence Measurement:** Measure the fluorescence emission at approximately 482 nm with an excitation wavelength of 450 nm. An increase in fluorescence intensity indicates fibril formation.

X-ray Crystallography of GNNQQNY Microcrystals

High-resolution structural information can be obtained from microcrystals of GNNQQNY.

- **Crystal Growth:** Dissolve GNNQQNY at a high concentration (e.g., 10-100 mM) in water. Microcrystals suitable for X-ray diffraction can form under these conditions.[14]
- **Data Collection:** Utilize a microfocus beamline at a synchrotron radiation facility to collect diffraction data from the small crystals.[14]
- **Structure Determination:** Process the diffraction data to determine the three-dimensional atomic structure of the peptide within the crystal lattice.[2]

Solid-State NMR (ssNMR) Spectroscopy

ssNMR is a powerful technique for studying the structure and dynamics of insoluble amyloid fibrils.

- **Isotope Labeling:** Synthesize GNNQQNY peptides with specific isotopic labels (e.g., ^{13}C , ^{15}N) at desired positions. This is crucial for resolving signals and obtaining distance restraints.[11][12]
- **Sample Preparation:** Pack the hydrated GNNQQNY fibrils into an MAS (Magic Angle Spinning) rotor.[11]
- **Data Acquisition:** Perform a series of multidimensional ssNMR experiments (e.g., 2D ^{13}C - ^{13}C correlation, REDOR) to obtain chemical shift assignments and intermolecular distance restraints.[1][11]
- **Structure Calculation:** Use the experimental restraints to calculate a high-resolution model of the GNNQQNY fibril.

Cryo-Electron Microscopy (Cryo-EM)

Cryo-EM allows for the direct visualization of amyloid fibrils in a near-native, frozen-hydrated state.

- **Sample Preparation:** Apply a small volume of the GNNQQNY fibril solution to an EM grid.

- **Vitrification:** Plunge-freeze the grid in liquid ethane to rapidly vitrify the sample, preserving the fibril structure.
- **Data Collection:** Acquire a large number of images of the frozen fibrils using a transmission electron microscope equipped with a direct electron detector.
- **Image Processing and 3D Reconstruction:** Use specialized software to process the images, classify different fibril morphologies, and reconstruct a three-dimensional density map of the fibril.
- **Model Building:** Build an atomic model of the GNNQQNY peptide into the cryo-EM density map.

Molecular Dynamics (MD) Simulations

MD simulations provide atomic-level insights into the dynamics and thermodynamics of GNNQQNY assembly.

- **System Setup:** Build an initial model of the GNNQQNY system (e.g., monomers in a water box, or a pre-formed oligomer).
- **Force Field Selection:** Choose an appropriate force field (e.g., CHARMM, AMBER) to describe the interactions between atoms.
- **Simulation:** Run the simulation for a sufficient length of time (nanoseconds to microseconds) to observe the desired molecular events (e.g., dimerization, oligomerization).
- **Analysis:** Analyze the simulation trajectory to calculate various properties, such as potential energy, root-mean-square deviation (RMSD), and hydrogen bond formation, to understand the assembly process.[\[15\]](#)[\[16\]](#)

Visualizing the Process: Signaling Pathways and Workflows

The following diagrams, generated using the DOT language, illustrate key aspects of GNNQQNY assembly and its investigation.

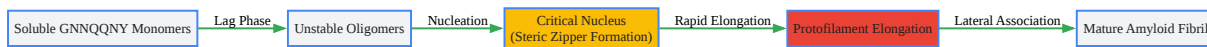

[Click to download full resolution via product page](#)

Caption: The nucleation-dependent assembly pathway of GNNQQNY into amyloid fibrils.

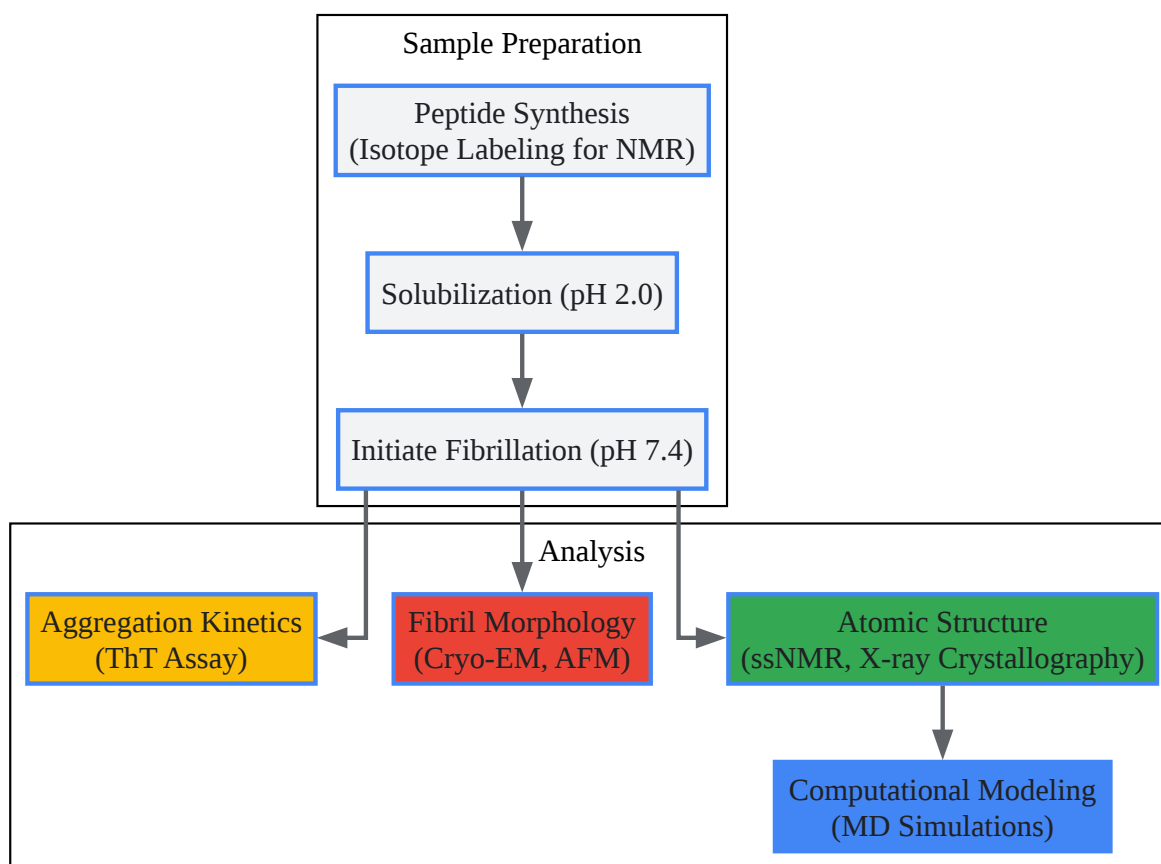

[Click to download full resolution via product page](#)

Caption: A typical experimental workflow for the investigation of GNNQQNY fibril assembly.

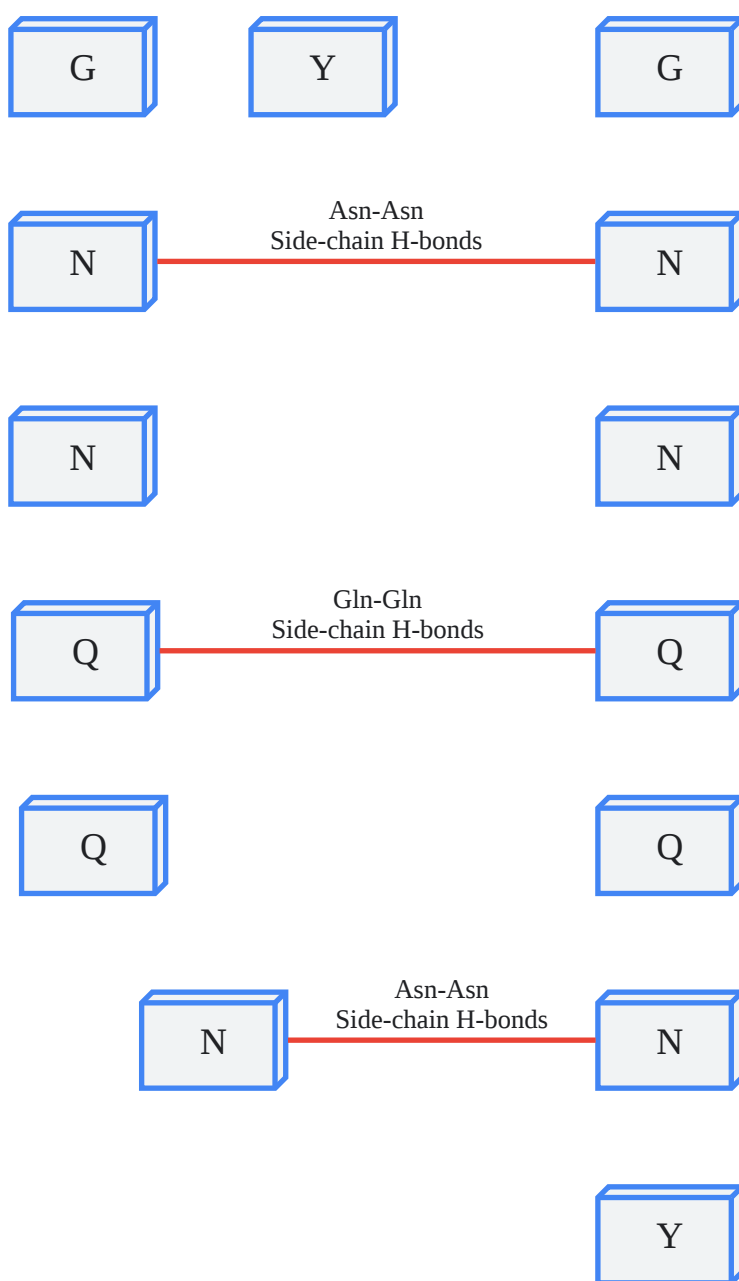

[Click to download full resolution via product page](#)

Caption: A schematic representation of the steric zipper formed by two GNNQQNY β-sheets.

Conclusion and Future Directions

The GNNQQNY peptide, with its well-characterized steric zipper, provides an invaluable model for dissecting the fundamental principles of amyloid assembly. The interplay of hydrogen bonding and shape complementarity within the steric zipper is the primary driving force for the remarkable stability and self-propagating nature of these fibrils. The detailed experimental

protocols and quantitative data presented in this guide offer a solid foundation for researchers aiming to further investigate this system.

Future research in this area will likely focus on several key aspects. The development of novel therapeutic strategies may involve the design of small molecules or peptides that can cap the ends of growing fibrils or disrupt the formation of the steric zipper. Higher-resolution structural studies of oligomeric intermediates will be crucial for understanding the earliest events in the aggregation cascade and for identifying the most toxic species. Furthermore, exploring the influence of cellular factors on GNNQQNY assembly will provide a more complete picture of amyloid formation in a biological context. By continuing to unravel the intricacies of the GNNQQNY steric zipper, the scientific community moves closer to understanding and ultimately combating the devastating consequences of amyloid-related diseases.

Need Custom Synthesis?

BenchChem offers custom synthesis for rare earth carbides and specific isotopic labeling.

Email: info@benchchem.com or [Request Quote Online](#).

References

- 1. Solid State NMR Studies of Amyloid Fibril Structure - PMC [[pmc.ncbi.nlm.nih.gov](https://pubmed.ncbi.nlm.nih.gov/)]
- 2. eisenberglab.mbi.ucla.edu [eisenberglab.mbi.ucla.edu]
- 3. [biorxiv.org](https://www.biorxiv.org/) [[biorxiv.org](https://www.biorxiv.org/)]
- 4. Structural Stability and Dynamics of an Amyloid-Forming Peptide GNNQQNY from the Yeast Prion Sup-35 - PMC [[pmc.ncbi.nlm.nih.gov](https://pubmed.ncbi.nlm.nih.gov/)]
- 5. Kinetics of Amyloid Aggregation: A Study of the GNNQQNY Prion Sequence - PMC [[pmc.ncbi.nlm.nih.gov](https://pubmed.ncbi.nlm.nih.gov/)]
- 6. [researchgate.net](https://www.researchgate.net/) [[researchgate.net](https://www.researchgate.net/)]
- 7. Thermodynamics and kinetics of aggregation for the GNNQQNY peptide - PubMed [pubmed.ncbi.nlm.nih.gov]
- 8. pubs.acs.org [pubs.acs.org]
- 9. Thermodynamic analysis of structural transitions during GNNQQNY aggregation - PubMed [pubmed.ncbi.nlm.nih.gov]

- 10. Molecular Dynamics Simulation of Self-Assembly Processes of Diphenylalanine Peptide Nanotubes and Determination of Their Chirality [mdpi.com]
- 11. Structural Characterization of GNNQQNY Amyloid Fibrils by Magic Angle Spinning NMR - PMC [pmc.ncbi.nlm.nih.gov]
- 12. pubs.acs.org [pubs.acs.org]
- 13. researchgate.net [researchgate.net]
- 14. williams.chemistry.gatech.edu [williams.chemistry.gatech.edu]
- 15. Molecular dynamics simulations on the oligomer-formation process of the GNNQQNY peptide from yeast prion protein Sup35 - PubMed [pubmed.ncbi.nlm.nih.gov]
- 16. pnas.org [pnas.org]
- To cite this document: BenchChem. [The Steric Zipper: A Linchpin in GNNQQNY Assembly and Amyloid Formation]. BenchChem, [2025]. [Online PDF]. Available at: [https://www.benchchem.com/product/b12385149#the-role-of-the-steric-zipper-in-gnnqqny-assembly]

Disclaimer & Data Validity:

The information provided in this document is for Research Use Only (RUO) and is strictly not intended for diagnostic or therapeutic procedures. While BenchChem strives to provide accurate protocols, we make no warranties, express or implied, regarding the fitness of this product for every specific experimental setup.

Technical Support: The protocols provided are for reference purposes. Unsure if this reagent suits your experiment? [[Contact our Ph.D. Support Team for a compatibility check](#)]

Need Industrial/Bulk Grade? [Request Custom Synthesis Quote](#)

BenchChem

Our mission is to be the trusted global source of essential and advanced chemicals, empowering scientists and researchers to drive progress in science and industry.

Contact

Address: 3281 E Guasti Rd
Ontario, CA 91761, United States
Phone: (601) 213-4426
Email: info@benchchem.com

