

The Role of DQP-26 in Neuroscience Research: A Technical Guide

Author: BenchChem Technical Support Team. **Date:** May 2026

Compound of Interest

Compound Name: DQP-26
Cat. No.: B12385009

[Get Quote](#)

For Researchers, Scientists, and Drug Development Professionals

This in-depth technical guide explores the significance and application of **DQP-26**, a pivotal chemical probe in the field of neuroscience. **DQP-26**, a dihydroquinoline-pyrazoline analogue, has emerged as a potent negative allosteric modulator (NAM) of the N-methyl-D-aspartate receptor (NMDAR), demonstrating notable selectivity for subunits containing GluN2C and GluN2D. This guide will delve into the quantitative data, experimental methodologies, and the broader context of its utility in studying NMDAR function and its potential implications for therapeutic development.

Core Data Presentation

The following tables summarize the quantitative data for **DQP-26** and its parent and derivative compounds, offering a clear comparison of their potency and selectivity for different NMDAR subunits.

Table 1: Inhibitory Potency (IC₅₀) of DQP-1105, **DQP-26**, and (S)-(-)-2i on NMDAR Subunits[1]
[2][3]

Compound	GluN1/GluN2A IC50 (μM)	GluN1/GluN2B IC50 (μM)	GluN1/GluN2C IC50 (μM)	GluN1/GluN2D IC50 (μM)
DQP-1105	>30	>30	7.0	2.7
DQP-26	~12.3	~21.1	0.77	0.44
(S)-(-)-2i	5.2	16	0.069	0.035

IC50 values represent the concentration of the compound required to inhibit 50% of the receptor's response.

Table 2: Subunit Selectivity of **DQP-26** and (S)-(-)-2i^{[1][2][3]}

Compound	Selectivity for GluN2D over GluN2A	Selectivity for GluN2D over GluN2B	Selectivity for GluN2C over GluN2A	Selectivity for GluN2C over GluN2B
DQP-26	~28-fold	~48-fold	-	-
(S)-(-)-2i	>300-fold	>450-fold	>100-fold	>230-fold

Selectivity is calculated as the ratio of IC50 values.

Key Experimental Protocols

The primary method for characterizing **DQP-26** and its analogues is two-electrode voltage-clamp (TEVC) electrophysiology using *Xenopus laevis* oocytes. This technique allows for the precise measurement of ion channel activity in a controlled environment.

Two-Electrode Voltage-Clamp (TEVC) Recording Protocol

- Oocyte Preparation and cRNA Injection:
 - *Xenopus laevis* oocytes are harvested and defolliculated.

- Oocytes are injected with complementary RNA (cRNA) encoding the human GluN1 subunit and one of the four human GluN2 subunits (GluN2A, GluN2B, GluN2C, or GluN2D).
- Injected oocytes are incubated for 24-72 hours to allow for receptor expression on the cell membrane.
- Electrophysiological Recording:
 - An oocyte expressing the desired NMDAR subtype is placed in a recording chamber and perfused with a standard recording solution (e.g., BaCl₂-based solution to minimize calcium-activated chloride currents).
 - Two microelectrodes, one for voltage sensing and one for current injection, are inserted into the oocyte.
 - The oocyte membrane potential is clamped at a holding potential of -40 mV to -70 mV.
- NMDAR Activation and Modulation:
 - The NMDARs are activated by the co-application of the agonists glutamate and glycine at concentrations that elicit a submaximal response (e.g., 100 μM glutamate and 30 μM glycine).
 - Once a stable baseline current is established, **DQP-26** or its analogues are co-applied with the agonists at varying concentrations to determine their inhibitory effect.
 - The current response is measured, and the concentration-response curve is plotted to calculate the IC₅₀ value.
- Data Analysis:
 - The peak current amplitude in the presence of the modulator is compared to the baseline current to determine the percentage of inhibition.
 - IC₅₀ values and Hill slopes are determined by fitting the concentration-response data to a logistical equation.

Visualizing the Molecular Interactions and Research Workflow

To better understand the context of **DQP-26** in neuroscience research, the following diagrams illustrate the NMDAR signaling pathway and the logical workflow of the structure-activity relationship studies that led to the development of more potent and selective analogues.

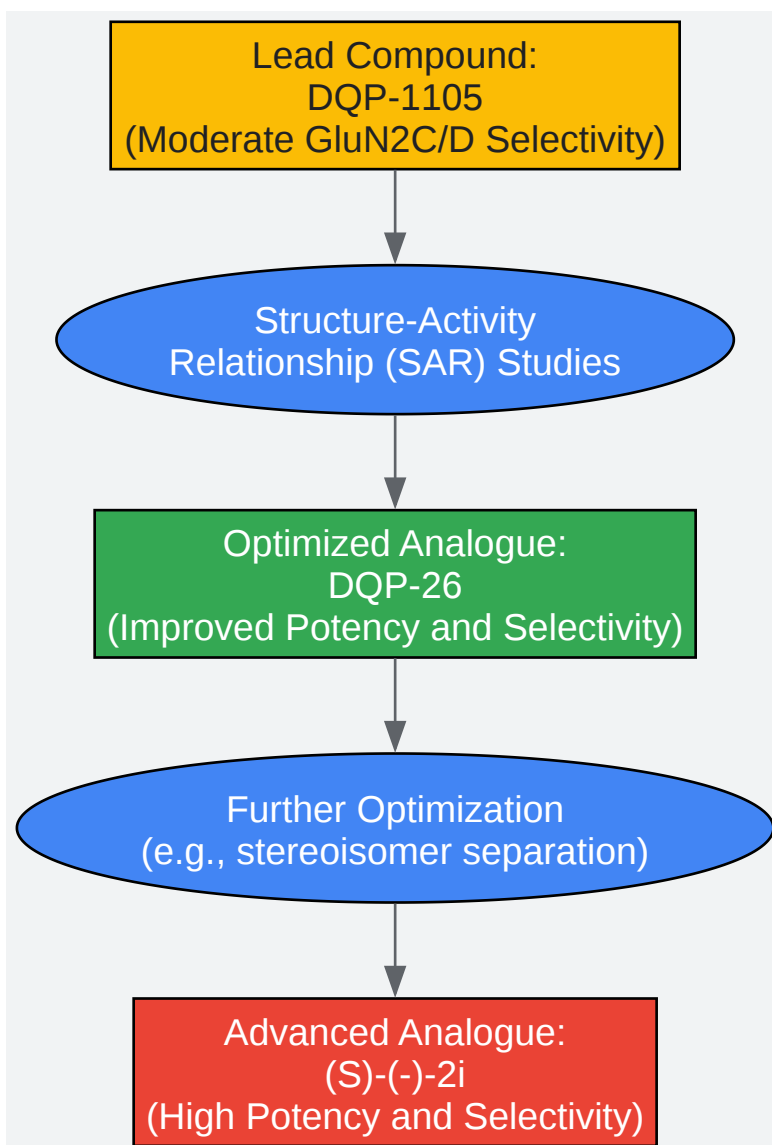
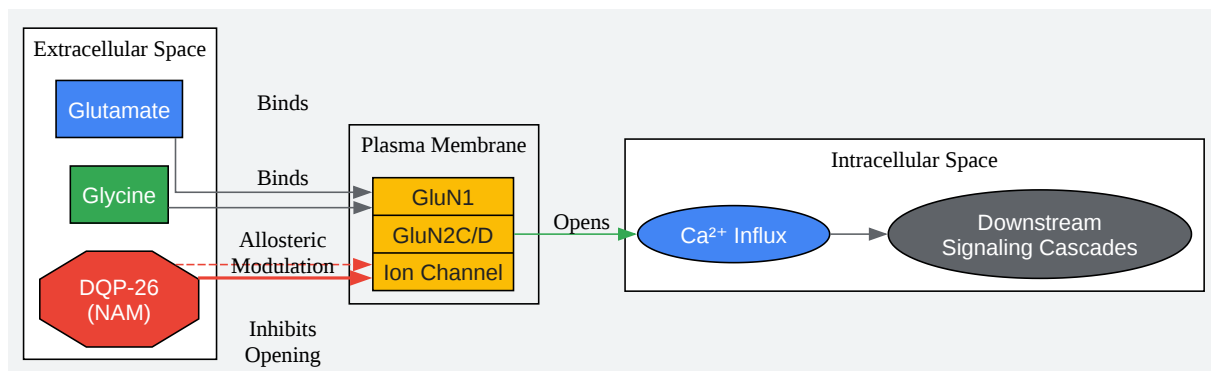

[Click to download full resolution via product page](#)

Need Custom Synthesis?

BenchChem offers custom synthesis for rare earth carbides and specific isotopic labeling.

Email: info@benchchem.com or [Request Quote Online](#).

References

- [1. Development of a Dihydroquinoline–Pyrazoline GluN2C/2D-Selective Negative Allosteric Modulator of the N-Methyl-d-aspartate Receptor - PMC \[pmc.ncbi.nlm.nih.gov\]](#)
- [2. pubs.acs.org \[pubs.acs.org\]](#)
- [3. Development of a Dihydroquinoline-Pyrazoline GluN2C/2D-Selective Negative Allosteric Modulator of the N-Methyl-d-aspartate Receptor - PubMed \[pubmed.ncbi.nlm.nih.gov\]](#)
- To cite this document: BenchChem. [The Role of DQP-26 in Neuroscience Research: A Technical Guide]. BenchChem, [2026]. [Online PDF]. Available at: [\[https://www.benchchem.com/product/b12385009/docs#the-role-of-dqp-26-in-neuroscience-research-a-technical-guide\]](https://www.benchchem.com/product/b12385009/docs#the-role-of-dqp-26-in-neuroscience-research-a-technical-guide)

Disclaimer & Data Validity:

The information provided in this document is for Research Use Only (RUO) and is strictly not intended for diagnostic or therapeutic procedures. While BenchChem strives to provide accurate protocols, we make no warranties, express or implied, regarding the fitness of this product for every specific experimental setup.

Technical Support: The protocols provided are for reference purposes. Unsure if this reagent suits your experiment?

Need Industrial/Bulk Grade? [Request Custom Synthesis Quote](#)

BenchChem

Our mission is to be the trusted global source of essential and advanced chemicals, empowering scientists and researchers to drive progress in science and industry.

Contact

Address: 3281 E Guasti Rd

Ontario, CA 91761, United States

Phone: (601) 213-4426

Email: info@benchchem.com

[Contact our Ph.D. Support Team for a compatibility check](#)