

The Impact of Pyk2-IN-2 on Downstream Signaling: A Technical Guide

Author: BenchChem Technical Support Team. **Date:** April 2026

Compound of Interest

Compound Name: Pyk2-IN-2
Cat. No.: B12385820

[Get Quote](#)

For Researchers, Scientists, and Drug Development Professionals

Proline-rich tyrosine kinase 2 (Pyk2), a non-receptor tyrosine kinase, serves as a critical signaling hub in a multitude of cellular processes. Its dysregulation is implicated in various pathologies, including cancer, neurological disorders, and inflammatory diseases. The development of specific inhibitors targeting Pyk2, such as **Pyk2-IN-2**, offers a promising therapeutic avenue. This technical guide provides an in-depth analysis of the downstream signaling pathways affected by **Pyk2-IN-2** treatment, supported by quantitative data, detailed experimental protocols, and pathway visualizations.

Pyk2-IN-2: A Specific Inhibitor of Pyk2 Kinase Activity

Pyk2-IN-2 is a small molecule inhibitor that targets the kinase activity of Pyk2. By blocking the ATP-binding site of the enzyme, **Pyk2-IN-2** prevents the phosphorylation of Pyk2 and its subsequent activation, thereby impeding downstream signaling cascades that regulate cell proliferation, migration, and survival.[1] **Pyk2-IN-2** exhibits a potent inhibitory effect on Pyk2 with a reported IC50 of 55 nM in cellular assays.[2] It also shows activity against the closely

related Focal Adhesion Kinase (FAK), with an IC50 of 0.608 μ M, indicating a degree of selectivity for Pyk2.[2][3][4][5]

Inhibitor	Target	IC50	Assay Type
Pyk2-IN-2	Pyk2	55 nM	Cellular Assay[2]
Pyk2-IN-2	FAK	0.608 μ M	Kinase Assay[2][3][4][5]

Core Downstream Signaling Pathways Modulated by Pyk2-IN-2

Pyk2 functions as a central node, integrating signals from various receptors, including growth factor receptors, integrins, and G-protein coupled receptors, to activate a network of downstream pathways.[6] Treatment with **Pyk2-IN-2** is expected to attenuate these pathways, leading to a range of cellular effects.

MAPK/ERK Signaling Pathway

The Mitogen-Activated Protein Kinase (MAPK)/Extracellular signal-Regulated Kinase (ERK) pathway is a crucial regulator of cell proliferation, differentiation, and survival. Pyk2 is known to be a key upstream activator of this pathway.[6] Upon activation, Pyk2 can recruit the Grb2/Sos complex, leading to the activation of Ras and the subsequent phosphorylation cascade of Raf, MEK, and ERK.[7]

Effect of Pyk2-IN-2 Treatment: By inhibiting Pyk2, **Pyk2-IN-2** treatment is expected to decrease the phosphorylation and activation of ERK1/2. This has been observed with other Pyk2 inhibitors, leading to reduced cell proliferation in various cancer models.[6] For instance, in Non-Small Cell Lung Cancer (NSCLC), Pyk2-mediated activation of ERK1/2 is associated with disease progression.[6]

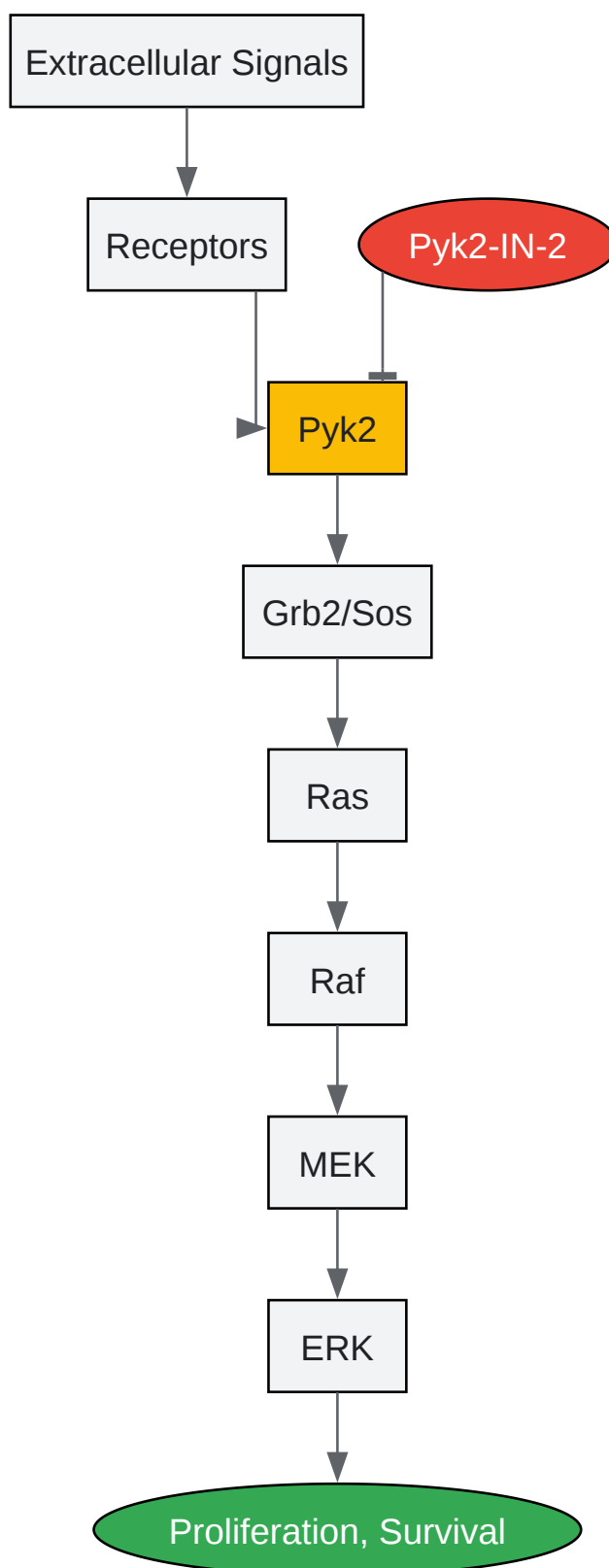

[Click to download full resolution via product page](#)

Pyk2-IN-2 inhibits the MAPK/ERK signaling pathway.

Cell Line	Treatment	Effect on p-ERK	Functional Outcome	Reference
NSCLC Cells	Pyk2 Inhibition	Decreased	Reduced Proliferation & Invasion	[6]
Prostate Cancer Cells	Pyk2 Inhibition	Decreased ERK/MAPK activity	Reduced Adhesion & Metastasis	[6]
Hepatocellular Carcinoma Cells	Pyk2 Inhibition	Decreased	Reduced Proliferation & Invasiveness	[6]

PI3K/Akt Signaling Pathway

The Phosphoinositide 3-Kinase (PI3K)/Akt pathway is another critical signaling cascade that governs cell survival, growth, and metabolism. Pyk2 can modulate this pathway, and its inhibition has been shown to decrease the phosphorylation of Akt.[6] This is particularly relevant in cancers like hepatocellular carcinoma and multiple myeloma, where Pyk2-mediated Akt activation contributes to drug resistance and tumor progression.[6]

Effect of **Pyk2-IN-2** Treatment: Treatment with **Pyk2-IN-2** would lead to a reduction in Akt phosphorylation (p-Akt), thereby promoting apoptosis and inhibiting cell survival.

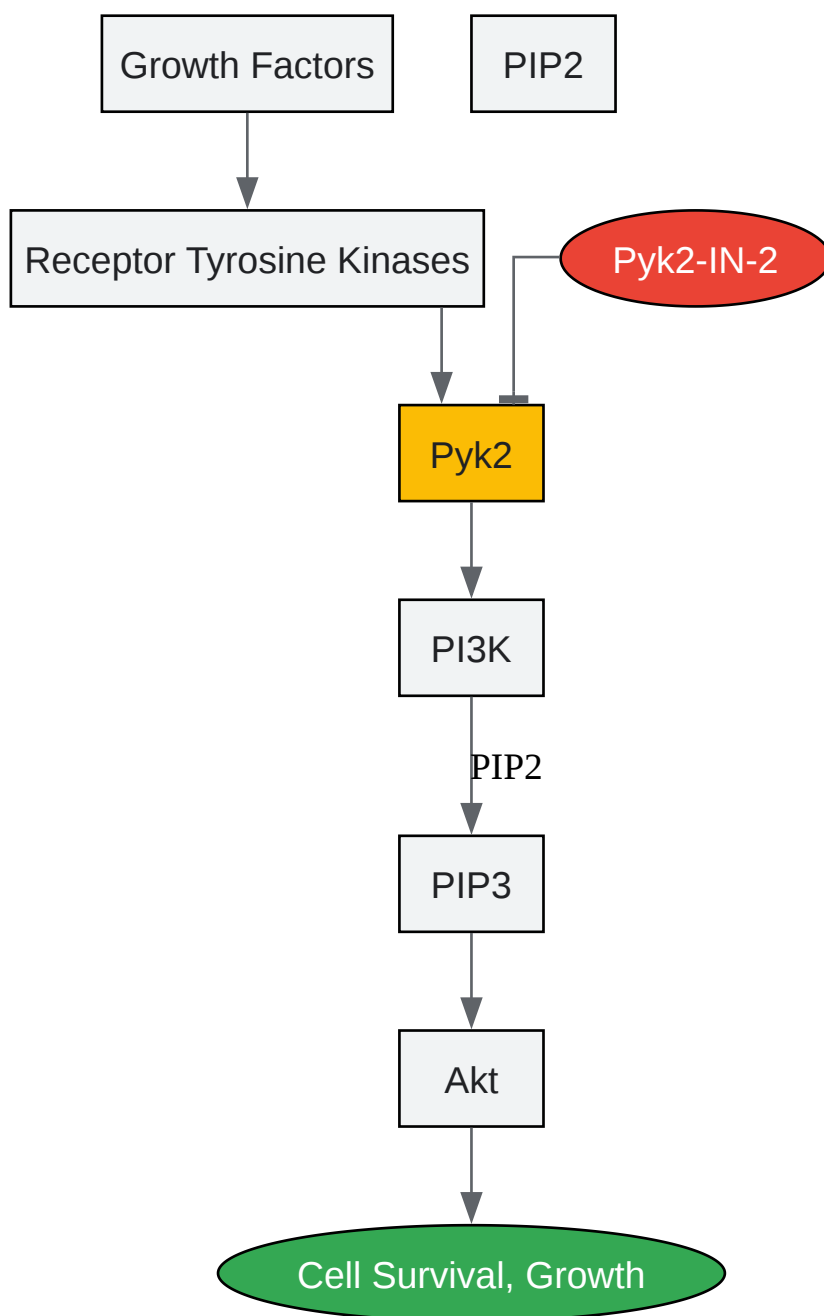

[Click to download full resolution via product page](#)

Pyk2-IN-2 inhibits the PI3K/Akt signaling pathway.

Cancer Type	Treatment	Effect on p-Akt	Functional Outcome	Reference
Hepatocellular Carcinoma	Pyk2 Inhibition	Decreased	Increased Cisplatin Sensitivity	[6]
Multiple Myeloma	Pyk2 Inhibition	Decreased	Destabilization of β -catenin	[6]

Src and Focal Adhesion Signaling

Pyk2 is a member of the focal adhesion kinase family and plays a pivotal role in cell adhesion, migration, and invasion.[8] Upon activation, Pyk2 undergoes autophosphorylation at Tyr402, which creates a binding site for the SH2 domain of Src family kinases.[9] This leads to the recruitment and activation of Src, which in turn phosphorylates other substrates like p130Cas and paxillin, promoting the formation of focal adhesions and cytoskeletal reorganization.[9]

Effect of **Pyk2-IN-2** Treatment: By preventing the autophosphorylation of Pyk2, **Pyk2-IN-2** will block the recruitment and activation of Src. This disrupts the downstream signaling cascade involving p130Cas and Crk, ultimately inhibiting cell migration and invasion.[9]

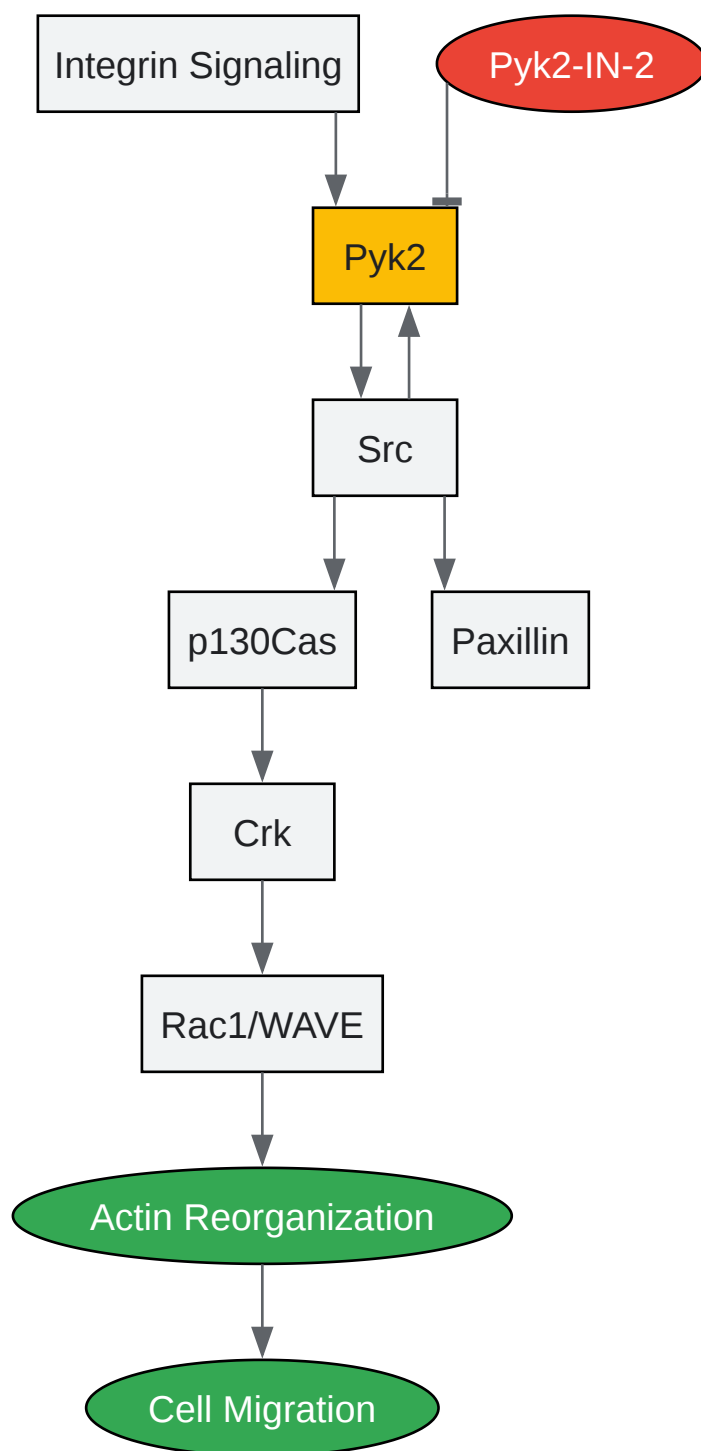

[Click to download full resolution via product page](#)

Pyk2-IN-2 disrupts Src and focal adhesion signaling.

Cell Type	Treatment	Effect on Phosphorylation	Functional Outcome	Reference
Fibroblasts	Pyk2 Knockout	N/A	Reduced cell-edge protrusion dynamics	[9]
Breast Cancer Cells	Pyk2 Activation by CCL18	Increased Pyk2 and Src phosphorylation	Promotes adhesion, migration, and invasion	[6]

Detailed Experimental Protocols

In Vitro Kinase Assay for Pyk2 Inhibition

Objective: To determine the half-maximal inhibitory concentration (IC50) of **Pyk2-IN-2** against Pyk2 kinase activity.

Materials:

- Recombinant human Pyk2 enzyme
- Kinase buffer (e.g., 50 mM HEPES pH 7.5, 10 mM MgCl₂, 1 mM EGTA, 0.01% Brij-35)
- ATP (at K_m concentration for Pyk2)
- Biotinylated peptide substrate (e.g., poly-Glu-Tyr, 4:1)
- **Pyk2-IN-2** (or other test compounds) at various concentrations
- Europium-labeled anti-phosphotyrosine antibody
- Streptavidin-Allophycocyanin (SA-APC)
- 384-well microplates
- Plate reader capable of Time-Resolved Fluorescence Resonance Energy Transfer (TR-FRET)

Procedure:

- Prepare serial dilutions of **Pyk2-IN-2** in DMSO and then dilute in kinase buffer.
- Add 5 μ L of the diluted compound or DMSO (vehicle control) to the wells of a 384-well plate.
- Add 5 μ L of Pyk2 enzyme solution to each well and incubate for 15 minutes at room temperature.
- Initiate the kinase reaction by adding 10 μ L of a mixture of ATP and biotinylated substrate.
- Incubate the reaction for 60 minutes at room temperature.
- Stop the reaction by adding 10 μ L of stop buffer containing EDTA.
- Add 10 μ L of a detection mixture containing Eu-labeled anti-phosphotyrosine antibody and SA-APC.
- Incubate for 60 minutes at room temperature to allow for antibody binding.
- Read the plate on a TR-FRET-compatible plate reader (e.g., excitation at 320 nm, emission at 615 nm and 665 nm).
- Calculate the ratio of the emission signals (665/615) and plot the percentage of inhibition against the logarithm of the compound concentration to determine the IC50 value using non-linear regression analysis.

Western Blot Analysis of Downstream Pathway Activation

Objective: To assess the effect of **Pyk2-IN-2** on the phosphorylation status of downstream signaling proteins like ERK and Akt.

Materials:

- Cell line of interest (e.g., HeLa, MCF-7)
- Cell culture medium and supplements

- **Pyk2-IN-2**
- Lysis buffer (e.g., RIPA buffer) with protease and phosphatase inhibitors
- BCA protein assay kit
- SDS-PAGE gels and electrophoresis apparatus
- PVDF membrane
- Transfer buffer and apparatus
- Blocking buffer (e.g., 5% non-fat milk or BSA in TBST)
- Primary antibodies (e.g., anti-p-Pyk2, anti-Pyk2, anti-p-ERK, anti-ERK, anti-p-Akt, anti-Akt, anti-GAPDH)
- HRP-conjugated secondary antibodies
- Enhanced chemiluminescence (ECL) substrate
- Chemiluminescence imaging system

Procedure:

- Seed cells in 6-well plates and allow them to adhere overnight.
- Treat the cells with various concentrations of **Pyk2-IN-2** or DMSO for the desired time period.
- Wash the cells with ice-cold PBS and lyse them with lysis buffer.
- Clarify the lysates by centrifugation and determine the protein concentration using the BCA assay.
- Denature the protein samples by boiling in Laemmli buffer.
- Separate the proteins by SDS-PAGE and transfer them to a PVDF membrane.

- Block the membrane with blocking buffer for 1 hour at room temperature.
- Incubate the membrane with primary antibodies overnight at 4°C.
- Wash the membrane with TBST and incubate with HRP-conjugated secondary antibodies for 1 hour at room temperature.
- Wash the membrane again and detect the protein bands using an ECL substrate and an imaging system.
- Quantify the band intensities using image analysis software and normalize the levels of phosphorylated proteins to the total protein levels.



[Click to download full resolution via product page](#)

Need Custom Synthesis?

BenchChem offers custom synthesis for rare earth carbides and specific isotopic labeling.

Email: info@benchchem.com or [Request Quote Online](#).

References

- [1. What are PYK2 inhibitors and how do they work? \[synapse.patsnap.com\]](https://synapse.patsnap.com)
- [2. medchemexpress.com \[medchemexpress.com\]](https://medchemexpress.com)
- [3. medchemexpress.com \[medchemexpress.com\]](https://medchemexpress.com)
- [4. PYK2 \(Inhibitors Agonists Modulators Antagonists\) | TargetMol \[targetmol.com\]](https://targetmol.com)
- [5. medchemexpress.com \[medchemexpress.com\]](https://medchemexpress.com)
- [6. Role of Pyk2 in Human Cancers - PMC \[pmc.ncbi.nlm.nih.gov\]](https://pubmed.ncbi.nlm.nih.gov)

- [7. Proline-Rich Protein Tyrosine Kinase 2 in Inflammation and Cancer - PMC](#)
[pmc.ncbi.nlm.nih.gov]
- [8. Pyk2 regulates cell-edge protrusion dynamics by interacting with Crk - PMC](#)
[pmc.ncbi.nlm.nih.gov]
- [9. researchgate.net](#) [researchgate.net]
- To cite this document: BenchChem. [The Impact of Pyk2-IN-2 on Downstream Signaling: A Technical Guide]. BenchChem, [2026]. [Online PDF]. Available at:
[<https://www.benchchem.com/product/b12385820/docs#the-impact-of-pyk2-in-2-on-downstream-signaling-a-technical-guide>]

Disclaimer & Data Validity:

The information provided in this document is for Research Use Only (RUO) and is strictly not intended for diagnostic or therapeutic procedures. While BenchChem strives to provide accurate protocols, we make no warranties, express or implied, regarding the fitness of this product for every specific experimental setup.

Technical Support: The protocols provided are for reference purposes. Unsure if this reagent suits your experiment?

Need Industrial/Bulk Grade? [Request Custom Synthesis Quote](#)

BenchChem

Our mission is to be the trusted global source of essential and advanced chemicals, empowering scientists and researchers to drive progress in science and industry.

Contact

Address: 3281 E Guasti Rd
Ontario, CA 91761, United States
Phone: (601) 213-4426
Email: info@benchchem.com

Contact our Ph.D. Support Team for a compatibility check