

Technical Support Center: PF-07208254 Cell-Based Assays

Author: BenchChem Technical Support Team. **Date:** April 2026

Compound of Interest

Compound Name: PF-07208254

Cat. No.: B12385626

[Get Quote](#)

This technical support center provides troubleshooting guidance and frequently asked questions (FAQs) for researchers using **PF-07208254** in cell-based assays. Our goal is to help you mitigate variability and ensure the reliability and reproducibility of your experimental data.

Frequently Asked Questions (FAQs)

Q1: What is the mechanism of action for **PF-07208254**?

A1: **PF-07208254** is a selective, orally active allosteric inhibitor of branched-chain ketoacid dehydrogenase kinase (BCKDK).[1] It functions by binding to an allosteric pocket of BCKDK, which in turn reduces the binding of BCKDK to the E2 subunit of the branched-chain ketoacid dehydrogenase (BCKDH) complex and promotes the degradation of BCKDK.[1][2] This inhibition of BCKDK prevents the phosphorylation and subsequent inactivation of the BCKDH complex, leading to an enhanced catabolism of branched-chain amino acids (BCAAs) and branched-chain keto acids (BCKAs).[1]

Q2: What are the key potency values for **PF-07208254**?

A2: The following table summarizes the key in vitro and cellular potency values for **PF-07208254**.

Parameter	Value	Cell/System	Reference
IC50	110 nM	Biochemical Assay	[1]
Ki	54 nM	Biochemical Assay	[1]
KD	84 nM	Biochemical Assay	[1]
Cellular IC50	540 nM	Human Skeletal Muscle Cells	[1][3]

Q3: Are there different classes of BDK inhibitors that might produce different results?

A3: Yes, it is crucial to be aware of the class of BDK inhibitor you are using. For instance, **PF-07208254** belongs to the thiophene class of BDK inhibitors.[2] Studies have shown that while thiophenes lead to a sustained lowering of branched-chain ketoacids (BCKAs) and a reduction in BDK protein levels, another class of BDK inhibitors, thiazoles, can have the opposite effect, increasing BCKAs and BDK protein levels.[2] This is because thiophenes reduce the proximity of BDK to BCKDH-E2, which may promote BDK degradation, whereas thiazoles increase this proximity.[2] Understanding this distinction is vital for interpreting your results correctly.

Troubleshooting Guides

Issue 1: High Variability Between Replicate Wells

Symptoms:

- Large standard deviations between replicate wells treated with **PF-07208254**.
- Inconsistent dose-response curves.
- Poor Z'-factor in screening assays.

Possible Causes and Solutions:

Cause	Troubleshooting Steps
Inconsistent Cell Seeding	- Thoroughly mix the cell suspension before and during plating to prevent settling. - Use a multichannel pipette for seeding and ensure all tips dispense equal volumes. - Allow the plate to sit at room temperature on a level surface for 15-20 minutes before incubation to ensure even cell distribution.[4]
Pipetting Errors	- Calibrate pipettes regularly. - Use the appropriate pipette for the volume being dispensed. - Pre-wet pipette tips before aspirating reagents. - Pipette slowly and consistently.[4]
Edge Effects	- To mitigate increased evaporation and temperature gradients in the outer wells, avoid using them for experimental samples. Instead, fill them with sterile water or media to create a humidity barrier. - Use plate sealers for long incubation periods.[4]
Incomplete Solubilization of PF-07208254	- Ensure complete solubilization of PF-07208254. A published protocol suggests preparing a stock solution in DMSO. For working solutions, a mixture of PEG300, Tween-80, and saline can be used to achieve a clear solution.[1] Always visually inspect for precipitates before adding to cells.

Issue 2: Weak or No Dose-Response to PF-07208254

Symptoms:

- No significant difference in assay signal between vehicle-treated and **PF-07208254**-treated wells.
- Flat dose-response curve.

Possible Causes and Solutions:

Cause	Troubleshooting Steps
Low Cell Number or Viability	- Optimize cell seeding density with a cell titration experiment. - Check cell viability using a method like trypan blue exclusion before seeding. - Ensure cells are in the logarithmic growth phase.[4]
Suboptimal Reagent Concentration	- Titrate key reagents, such as antibodies or detection substrates, to determine the optimal concentration for your cell type and density.[4]
Incorrect Incubation Times	- Optimize the incubation time for PF-07208254 treatment. In HEK293 cells, a 48-hour incubation has been shown to be effective.[1]
Degraded PF-07208254	- Check the expiration date of your compound. - Store PF-07208254 according to the manufacturer's instructions, protecting it from light and moisture.
Cell Line Insensitivity	- Ensure your chosen cell line expresses BDK and the BCKDH complex. - Consider that the cellular IC ₅₀ (e.g., 540 nM in human skeletal muscle cells) can be higher than the biochemical IC ₅₀ . [1]

Issue 3: High Background Signal

Symptoms:

- High signal in negative control (vehicle only) wells.
- Reduced dynamic range of the assay.

Possible Causes and Solutions:

Cause	Troubleshooting Steps
Overly High Cell Seeding Density	- Reduce the number of cells seeded per well. Overconfluent cells can lead to non-specific signals.[4]
Autofluorescence of PF-07208254 or Cells	- If using a fluorescence-based assay, check for autofluorescence of your cells and PF-07208254 at the excitation and emission wavelengths used. - Use appropriate filters to minimize background.[4]
Contaminated Media or Reagents	- Use fresh, sterile media and reagents. - Routinely test for mycoplasma contamination, as it can alter cellular metabolism and assay results.[5]
Non-specific Antibody Binding (for immunoassays)	- Increase the concentration of the blocking agent or try a different blocking buffer. - Titrate the primary and secondary antibody concentrations to find the lowest concentration that gives a specific signal.[4]

Experimental Protocols

Protocol 1: General Cell Treatment with **PF-07208254**

- **Cell Seeding:** Plate cells at a pre-optimized density in a suitable microplate format. Allow cells to adhere and reach the desired confluency (typically 24 hours).
- **PF-07208254 Preparation:** Prepare a stock solution of **PF-07208254** in DMSO. On the day of the experiment, perform serial dilutions to achieve the desired final concentrations in your cell culture medium. Ensure the final DMSO concentration is consistent across all wells, including the vehicle control (typically $\leq 0.1\%$).
- **Cell Treatment:** Remove the existing medium from the cells and replace it with the medium containing the various concentrations of **PF-07208254** or vehicle control.

- Incubation: Incubate the cells for the desired period (e.g., 48 hours, as used in HEK293 cells^[1]).
- Assay Readout: Proceed with your specific assay to measure the desired endpoint (e.g., pBCKDH levels, cell viability, etc.).

Protocol 2: Western Blot for pBCKDH/BCKDH Ratio

- Cell Lysis: After treatment with **PF-07208254**, wash cells with ice-cold PBS and lyse with a suitable lysis buffer containing protease and phosphatase inhibitors.
- Protein Quantification: Determine the protein concentration of each lysate using a standard method (e.g., BCA assay).
- SDS-PAGE and Transfer: Separate equal amounts of protein from each sample by SDS-PAGE and transfer to a PVDF or nitrocellulose membrane.
- Blocking: Block the membrane with a suitable blocking buffer (e.g., 5% non-fat milk or BSA in TBST) for 1 hour at room temperature.
- Antibody Incubation: Incubate the membrane with primary antibodies against phosphorylated BCKDH (pBCKDH) and total BCKDH overnight at 4°C.
- Secondary Antibody and Detection: Wash the membrane and incubate with the appropriate HRP-conjugated secondary antibody. Detect the signal using an enhanced chemiluminescence (ECL) substrate.
- Analysis: Quantify the band intensities for pBCKDH and total BCKDH. Calculate the pBCKDH/BCKDH ratio for each treatment condition.

Visualizations

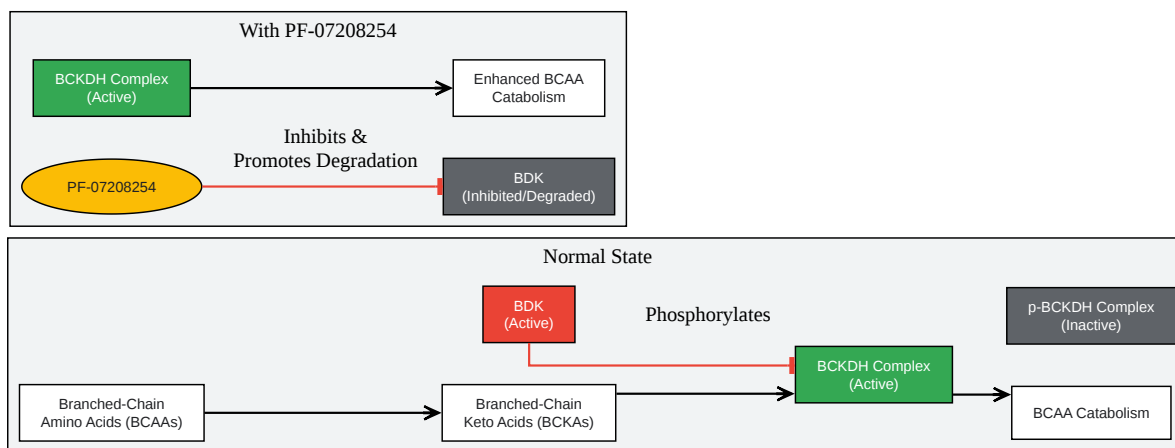

[Click to download full resolution via product page](#)

Caption: **PF-07208254** mechanism of action.

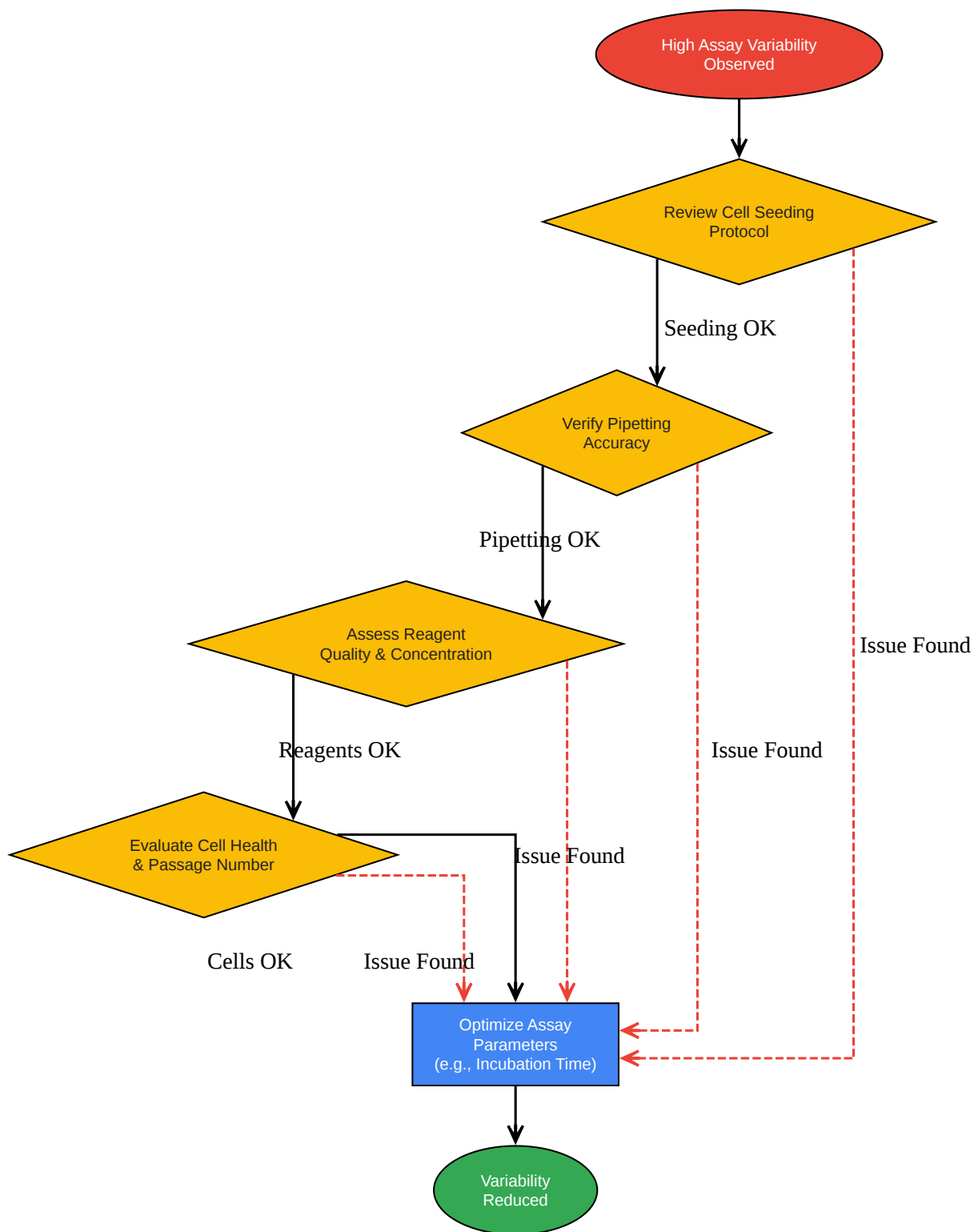

[Click to download full resolution via product page](#)

Caption: General troubleshooting workflow for assay variability.

Need Custom Synthesis?

BenchChem offers custom synthesis for rare earth carbides and specific isotopic labeling.

Email: info@benchchem.com or [Request Quote Online](#).

References

- [1. medchemexpress.com \[medchemexpress.com\]](https://www.medchemexpress.com)
- [2. Small molecule branched-chain ketoacid dehydrogenase kinase \(BDK\) inhibitors with opposing effects on BDK protein levels - PubMed \[pubmed.ncbi.nlm.nih.gov\]](#)
- [3. Small molecule branched-chain ketoacid dehydrogenase kinase \(BDK\) inhibitors with opposing effects on BDK protein levels - PMC \[pmc.ncbi.nlm.nih.gov\]](#)
- [4. benchchem.com \[benchchem.com\]](https://www.benchchem.com)
- [5. youtube.com \[youtube.com\]](https://www.youtube.com)
- To cite this document: BenchChem. [Technical Support Center: PF-07208254 Cell-Based Assays]. BenchChem, [2026]. [Online PDF]. Available at: [\[https://www.benchchem.com/product/b12385626/docs#technical-support-center-pf-07208254-cell-based-assays\]](https://www.benchchem.com/product/b12385626/docs#technical-support-center-pf-07208254-cell-based-assays)

Disclaimer & Data Validity:

The information provided in this document is for Research Use Only (RUO) and is strictly not intended for diagnostic or therapeutic procedures. While BenchChem strives to provide accurate protocols, we make no warranties, express or implied, regarding the fitness of this product for every specific experimental setup.

Technical Support: The protocols provided are for reference purposes. Unsure if this reagent suits your experiment?

Need Industrial/Bulk Grade? [Request Custom Synthesis Quote](#)

BenchChem

Our mission is to be the trusted global source of essential and advanced chemicals, empowering scientists and researchers to drive progress in science and industry.

Contact

Address: 3281 E Guasti Rd

Ontario, CA 91761, United States

Phone: (601) 213-4426

Email: info@benchchem.com

[Contact our Ph.D. Support Team for a compatibility check](#)