

Technical Support Center: DQP-26

Pharmacokinetics and Brain Distribution

Author: BenchChem Technical Support Team. **Date:** May 2026

Compound of Interest

Compound Name: DQP-26
Cat. No.: B12385009

[Get Quote](#)

This technical support center provides troubleshooting guides and frequently asked questions (FAQs) for researchers, scientists, and drug development professionals working with **DQP-26**, a potent and selective negative allosteric modulator (NAM) of GluN2C/D-containing N-methyl-D-aspartate (NMDA) receptors. This guide focuses on the known challenges associated with its pharmacokinetics and brain distribution.

Frequently Asked Questions (FAQs)

Q1: What is **DQP-26** and what is its primary mechanism of action?

A1: **DQP-26** is a dihydroquinoline-pyrazoline analog that acts as a negative allosteric modulator of NMDA receptors with selectivity for those containing the GluN2C and GluN2D subunits. It inhibits receptor function in a noncompetitive and voltage-independent manner. Its inhibitory effect is enhanced in the presence of glutamate.

Q2: What are the main challenges observed in preclinical studies with **DQP-26**?

A2: A primary challenge in the development of **DQP-26** as an in vivo tool is its poor brain penetration and inadequate cell-membrane permeability. These characteristics can lead to sub-

therapeutic concentrations at the target site within the central nervous system (CNS), limiting its efficacy in in vivo models.

Q3: Has the brain penetration of **DQP-26** been improved?

A3: Efforts have been made to enhance the pharmacokinetic profile of the dihydroquinoline-pyrazoline series. One strategy that has been explored is the use of prodrugs to mask the carboxylic acid moiety, which is thought to contribute to the poor membrane permeability.

Q4: What is the potential therapeutic relevance of targeting GluN2C/D subunits with compounds like **DQP-26**?

A4: Selective inhibition of GluN2C/D-containing NMDA receptors is a promising therapeutic strategy for several neurological and psychiatric disorders, including epilepsy, movement disorders, and schizophrenia, where these subunits are believed to play a significant pathophysiological role.

Troubleshooting Guide

Issue: Low or undetectable brain concentrations of **DQP-26** in in vivo studies.

Possible Causes and Solutions:

- Poor Blood-Brain Barrier (BBB) Permeability: The inherent physicochemical properties of **DQP-26**, such as high polarity or being a substrate for efflux transporters at the BBB, can severely limit its brain uptake.
 - Troubleshooting Steps:
 - Verify Compound Integrity: Ensure the compound is stable in the vehicle and under physiological conditions.
 - In Vitro Permeability Assessment: Conduct in vitro BBB permeability assays (e.g., PAMPA-BBB or cell-based transwell assays) to confirm low permeability.
 - Efflux Transporter Substrate Identification: Use cell lines overexpressing efflux transporters (e.g., P-gp, BCRP) to determine if **DQP-26** is a substrate. Co-

administration with known efflux pump inhibitors can be explored in vivo, though this can have confounding effects.

- Prodrug Strategy: Consider synthesizing and testing a lipophilic prodrug of **DQP-26** to enhance its ability to cross the BBB.
- Alternative Routes of Administration: For proof-of-concept studies, direct administration into the CNS (e.g., intracerebroventricular injection) can bypass the BBB.
- Rapid Peripheral Metabolism: **DQP-26** might be rapidly metabolized in the liver or plasma, leading to low systemic exposure and consequently low brain concentrations.
 - Troubleshooting Steps:
 - Metabolic Stability Assays: Perform in vitro metabolic stability assays using liver microsomes or hepatocytes to determine the metabolic rate.
 - Pharmacokinetic Studies: Conduct a full pharmacokinetic study to determine key parameters like clearance and half-life. If clearance is high and half-life is short, this may indicate rapid metabolism.
 - Identify Metabolites: Use LC-MS/MS to identify major metabolites in plasma and liver microsome incubations. This can provide insights into the metabolic pathways and potential sites for chemical modification to improve stability.
- High Plasma Protein Binding: Extensive binding to plasma proteins can reduce the free fraction of **DQP-26** available to cross the BBB.
 - Troubleshooting Steps:
 - Determine Plasma Protein Binding: Use techniques like equilibrium dialysis or ultrafiltration to measure the extent of plasma protein binding.
 - Structure-Activity Relationship (SAR) Studies: If protein binding is excessively high, explore SAR to identify modifications that can reduce it without compromising target potency.

Quantitative Data

While specific pharmacokinetic parameters for **DQP-26** are not readily available in the public domain, data for a close structural analog, (S)-(-)-2i (DQP-997-74), provides insight into the challenges of this compound class.

Table 1: Brain and Plasma Concentrations of DQP-997-74 in Mice

| Route of Administration | Dose (mg/kg) | Time Point | Plasma Concentration (ng/mL) | Brain Concentration (ng/g) |
|-------------------------|--------------|------------|------------------------------|----------------------------|
| Intraperitoneal (IP) | 10 | 15 min | 1200 | 23 |
| | | 30 min | 1100 | 20 |
| | | 1 hr | 900 | 18 |
| | | 2 hr | 700 | 15 |
| | | 4 hr | 500 | 12 |
| Intravenous (IV) | 5 | 15 min | 642 | 14 |
| | | 30 min | 300 | 8 |
| | | 1 hr | 150 | 4 |
| | | 2 hr | 50 | < LOQ |
| | | 4 hr | < LOQ | < LOQ |

Data adapted from a study on a close analog of **DQP-26**. LOQ = Limit of Quantitation.

Experimental Protocols

In Vitro Blood-Brain Barrier Permeability Assay (Parallel Artificial Membrane Permeability Assay - PAMPA-BBB)

This assay provides a high-throughput method to predict the passive permeability of a compound across the BBB.

- Materials:
 - PAMPA plate (e.g., 96-well format with a lipid-coated filter)
 - Phosphate buffered saline (PBS), pH 7.4
 - Test compound (**DQP-26**) stock solution in DMSO
 - Reference compounds with known BBB permeability (high and low)
 - UV-Vis plate reader or LC-MS/MS for quantification
- Methodology:
 - Prepare a donor solution by diluting the **DQP-26** stock solution in PBS to the final desired concentration (typically with a final DMSO concentration of <1%).
 - Add the donor solution to the donor wells of the PAMPA plate.
 - Fill the acceptor wells with PBS.
 - Carefully place the filter plate onto the acceptor plate, ensuring the lipid membrane is in contact with both the donor and acceptor solutions.
 - Incubate the plate assembly at room temperature for a defined period (e.g., 4-18 hours) with gentle shaking.
 - After incubation, carefully separate the plates.
 - Determine the concentration of **DQP-26** in both the donor and acceptor wells using a suitable analytical method (e.g., UV-Vis spectroscopy or LC-MS/MS).
 - Calculate the permeability coefficient (P_e) using the following equation: $P_e = (-V_A / (\text{Area} * \text{time})) * \ln(1 - [C_A] / [C_D, \text{equilibrium}])$ where V_A is the volume of the acceptor well, Area is the filter area, time is the incubation time, $[C_A]$ is the concentration in the acceptor well, and $[C_D, \text{equilibrium}]$ is the concentration at equilibrium.

LC-MS/MS Quantification of DQP-26 in Plasma and Brain Homogenate

This method allows for the sensitive and specific quantification of **DQP-26** in biological matrices.

- Materials:
 - LC-MS/MS system (e.g., triple quadrupole mass spectrometer)
 - C18 reversed-phase HPLC column
 - Mobile phases (e.g., water with 0.1% formic acid and acetonitrile with 0.1% formic acid)
 - Internal standard (IS) (e.g., a stable isotope-labeled **DQP-26** or a structurally similar compound)
 - Plasma and brain tissue samples
 - Protein precipitation solvent (e.g., acetonitrile)
 - Homogenizer for brain tissue
- Methodology:
 - Sample Preparation (Plasma):
 - Thaw plasma samples on ice.
 - To a 50 μ L aliquot of plasma, add the IS solution.
 - Add 3 volumes of ice-cold acetonitrile to precipitate proteins.
 - Vortex and centrifuge at high speed to pellet the precipitated proteins.
 - Transfer the supernatant to a new tube and evaporate to dryness under a stream of nitrogen.

- Reconstitute the residue in the initial mobile phase for LC-MS/MS analysis.
- Sample Preparation (Brain):
 - Weigh a portion of the brain tissue and homogenize it in 4 volumes of PBS.
 - Use an aliquot of the brain homogenate and follow the same protein precipitation and extraction procedure as for plasma.
- LC-MS/MS Analysis:
 - Inject the reconstituted sample onto the LC-MS/MS system.
 - Develop a chromatographic method to separate **DQP-26** from endogenous matrix components.
 - Optimize the mass spectrometer parameters (e.g., precursor and product ions for multiple reaction monitoring - MRM) for both **DQP-26** and the IS.
 - Generate a calibration curve using known concentrations of **DQP-26** spiked into the corresponding blank matrix (plasma or brain homogenate).
 - Quantify the concentration of **DQP-26** in the samples by comparing the peak area ratio of the analyte to the IS against the calibration curve.

Visualizations

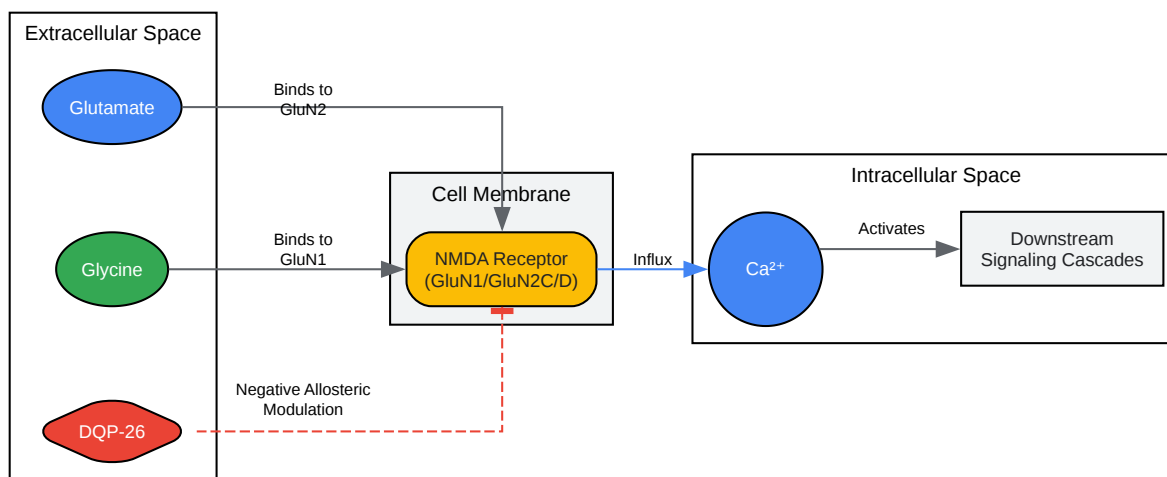

[Click to download full resolution via product page](#)

Caption: **DQP-26** Signaling Pathway

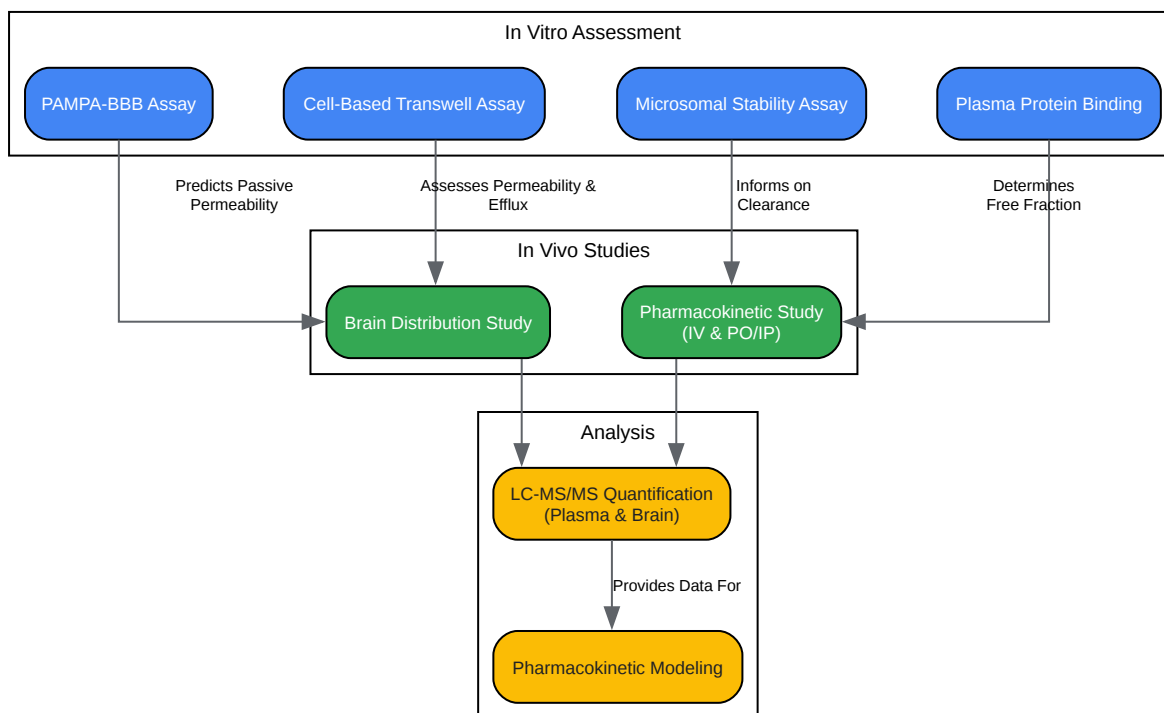

[Click to download full resolution via product page](#)

- To cite this document: BenchChem. [Technical Support Center: DQP-26 Pharmacokinetics and Brain Distribution]. BenchChem, [2026]. [Online PDF]. Available at: [\[https://www.benchchem.com/product/b12385009/docs#technical-support-center-dqp-26-pharmacokinetics-and-brain-distribution\]](https://www.benchchem.com/product/b12385009/docs#technical-support-center-dqp-26-pharmacokinetics-and-brain-distribution)

Disclaimer & Data Validity:

The information provided in this document is for Research Use Only (RUO) and is strictly not intended for diagnostic or therapeutic procedures. While BenchChem strives to provide accurate protocols, we make no warranties, express or implied, regarding the fitness of this product for every specific experimental setup.

Technical Support: The protocols provided are for reference purposes. Unsure if this reagent suits your experiment?

Need Industrial/Bulk Grade? [Request Custom Synthesis Quote](#)

BenchChem

Our mission is to be the trusted global source of essential and advanced chemicals, empowering scientists and researchers to drive progress in science and industry.

Contact

Address: 3281 E Guasti Rd
Ontario, CA 91761, United States
Phone: (601) 213-4426
Email: info@benchchem.com

[Contact our Ph.D. Support Team for a compatibility check](#)