

Potential off-target effects of Jak-IN-26

Author: BenchChem Technical Support Team. **Date:** April 2026

Compound of Interest

Compound Name: *Jak-IN-26*
Cat. No.: *B12385350*

[Get Quote](#)

Technical Support Center: Jak-IN-26

This technical support center provides troubleshooting guides and frequently asked questions (FAQs) for researchers, scientists, and drug development professionals using **Jak-IN-26**. The information is presented in a question-and-answer format to directly address specific issues that may be encountered during experimentation.

Frequently Asked Questions (FAQs)

Q1: What is the primary mechanism of action for **Jak-IN-26**?

A1: **Jak-IN-26** is a small molecule inhibitor that targets the Janus kinase (JAK) family of enzymes.^[1] These enzymes are crucial for the signaling of numerous cytokines and growth factors involved in inflammation and immune responses.^{[2][3]} By binding to the ATP-binding site of JAKs, **Jak-IN-26** prevents the phosphorylation and activation of Signal Transducer and Activator of Transcription (STAT) proteins, thereby blocking the downstream signaling cascade.^{[1][4]}

Q2: Which JAK isoforms is **Jak-IN-26** expected to inhibit?

A2: The precise selectivity profile of **Jak-IN-26** should be determined experimentally. Generally, JAK inhibitors can exhibit varying degrees of selectivity for the four members of the JAK family:

JAK1, JAK2, JAK3, and TYK2.[2][5] The selectivity profile is critical as it dictates the spectrum of biological effects and potential off-target activities.[5] For instance, inhibition of JAK2 homodimers can affect hematopoiesis, potentially leading to anemia or thrombocytopenia.[1]

Q3: What are the potential off-target effects of **Jak-IN-26**?

A3: As with other small molecule kinase inhibitors, **Jak-IN-26** may have off-target effects. These can arise from the inhibition of other kinases or non-kinase proteins.[6][7] Common adverse events observed with JAK inhibitors in clinical settings, which may translate to off-target effects in research, include:

- Hematological effects: Anemia, neutropenia, and thrombocytopenia due to inhibition of JAK2-mediated signaling.[1][8]
- Immunosuppression: Increased susceptibility to infections due to the broad inhibition of cytokine signaling.[9][10]
- Metabolic changes: Increases in cholesterol levels have been reported with some JAK inhibitors.[8][9]
- Gastrointestinal issues: Nausea and diarrhea can be potential side effects.[11]

It is crucial to empirically determine the off-target profile of **Jak-IN-26** in your experimental system.

Q4: How can I assess the selectivity of **Jak-IN-26** in my experiments?

A4: Assessing kinase selectivity is a critical step. Two common approaches are:

- Biochemical Assays: These cell-free assays measure the direct inhibition of a panel of purified kinases.[5][12] This provides a direct measure of the inhibitor's potency against each kinase.
- Cellular Assays: These assays are performed in a cellular context and measure the inhibition of specific signaling pathways downstream of different kinases.[13] This can provide a more physiologically relevant assessment of selectivity.

Troubleshooting Guides

Problem 1: I am observing unexpected or inconsistent results in my cell-based assays.

- Question: Could off-target effects be influencing my results?
 - Answer: Yes, unexpected phenotypes could be due to the inhibition of kinases other than the intended JAK target. It is recommended to perform a broad-panel kinase screen to identify potential off-target interactions.^{[7][12]} Additionally, consider that at higher concentrations, the selectivity of the inhibitor may decrease, leading to the engagement of other JAK family members or unrelated kinases.^[1]
- Question: How can I confirm that the observed effect is due to JAK inhibition?
 - Answer: To confirm on-target activity, you can perform a rescue experiment by introducing a constitutively active or inhibitor-resistant mutant of the target JAK. Alternatively, you can use siRNA or shRNA to knock down the target JAK and see if it phenocopies the effect of **Jak-IN-26**. A western blot to check the phosphorylation status of downstream STAT proteins is also a direct way to measure target engagement.

Problem 2: I am seeing significant cell toxicity or death at my desired inhibitor concentration.

- Question: Is the observed toxicity due to on-target or off-target effects?
 - Answer: Toxicity can result from potent on-target inhibition of a critical cellular pathway or from off-target effects. To distinguish between these, you can compare the phenotype with that of other JAK inhibitors with different selectivity profiles. If multiple JAK inhibitors with varying structures and off-target profiles produce the same toxicity, it is more likely to be an on-target effect.
- Question: How can I mitigate the toxicity?
 - Answer: Try performing a dose-response experiment to determine the lowest effective concentration that still provides the desired level of JAK inhibition. You can also try reducing the treatment duration. If toxicity persists, consider using a more selective JAK inhibitor if available.

Problem 3: The inhibitor does not seem to be working in my cellular assay, even at high concentrations.

- Question: How can I be sure the inhibitor is cell-permeable and stable?
 - Answer: Ensure that the inhibitor is properly dissolved and that the final concentration of the solvent (e.g., DMSO) is not affecting the cells. The stability of the compound in your cell culture media and conditions should also be considered. You can perform a cellular thermal shift assay (CETSA) to confirm target engagement within the cell.
- Question: Could my cells be resistant to the inhibitor?
 - Answer: Cells can develop resistance to kinase inhibitors through various mechanisms. Confirm the expression and activity of the target JAK in your cell line. Also, ensure that the signaling pathway you are measuring is indeed active in your specific cellular model.

Data Presentation

Table 1: Representative Kinase Selectivity Profiles of Clinically Studied JAK Inhibitors (IC50 in nM)

Kinase	Tofacitinib	Baricitinib	Ruxolitinib	Filgotinib	Upadacitinib
JAK1	1.2	5.9	3.3	10	43
JAK2	20	5.7	2.8	28	110
JAK3	1.0	>400	19.3	810	>5000
TYK2	56	53	428	116	2300

Data compiled from various sources and should be used for comparative purposes. Actual IC50 values can vary based on assay conditions.[\[14\]](#)[\[15\]](#)

Experimental Protocols

Protocol 1: General Workflow for Biochemical Kinase Profiling

This protocol outlines a general procedure for assessing the selectivity of **Jak-IN-26** against a panel of purified kinases.

- **Compound Preparation:** Prepare a stock solution of **Jak-IN-26** in a suitable solvent (e.g., DMSO). Create a serial dilution of the compound to be tested.
- **Kinase Reaction Setup:** In a microplate, add the purified kinase, a suitable substrate (e.g., a peptide substrate), and ATP.
- **Inhibitor Addition:** Add the diluted **Jak-IN-26** or vehicle control to the kinase reaction wells.
- **Incubation:** Incubate the plate at the optimal temperature for the kinase reaction (e.g., 30°C) for a specified period (e.g., 60 minutes).
- **Detection:** Stop the reaction and measure the kinase activity. This is often done by quantifying the amount of phosphorylated substrate or the amount of ADP produced. Several commercial kits are available for this purpose (e.g., ADP-Glo™, LanthaScreen™).
- **Data Analysis:** Calculate the percent inhibition for each concentration of **Jak-IN-26**. Determine the IC50 value for each kinase by fitting the data to a dose-response curve.

Protocol 2: Cellular Assay for Assessing JAK1/STAT3 Pathway Inhibition

This protocol describes a method to measure the inhibition of IL-6-induced STAT3 phosphorylation in a cellular context.

- **Cell Culture:** Plate cells that are responsive to IL-6 (e.g., HeLa or specific immune cells) in a suitable culture plate and allow them to adhere or stabilize overnight.
- **Inhibitor Pre-treatment:** Pre-incubate the cells with various concentrations of **Jak-IN-26** or a vehicle control for a specified time (e.g., 1-2 hours).
- **Cytokine Stimulation:** Stimulate the cells with an appropriate concentration of Interleukin-6 (IL-6) to activate the JAK1/STAT3 pathway.
- **Cell Lysis:** After a short incubation period with IL-6 (e.g., 15-30 minutes), wash the cells with cold PBS and lyse them with a suitable lysis buffer containing phosphatase and protease

inhibitors.

- Protein Quantification: Determine the protein concentration of each cell lysate.
- Western Blotting or ELISA: Analyze the phosphorylation of STAT3 (p-STAT3) and total STAT3 levels using western blotting or a specific ELISA kit.
- Data Analysis: Quantify the p-STAT3 signal and normalize it to the total STAT3 signal. Calculate the percent inhibition of STAT3 phosphorylation at each concentration of **Jak-IN-26** and determine the IC50 value.

Visualizations

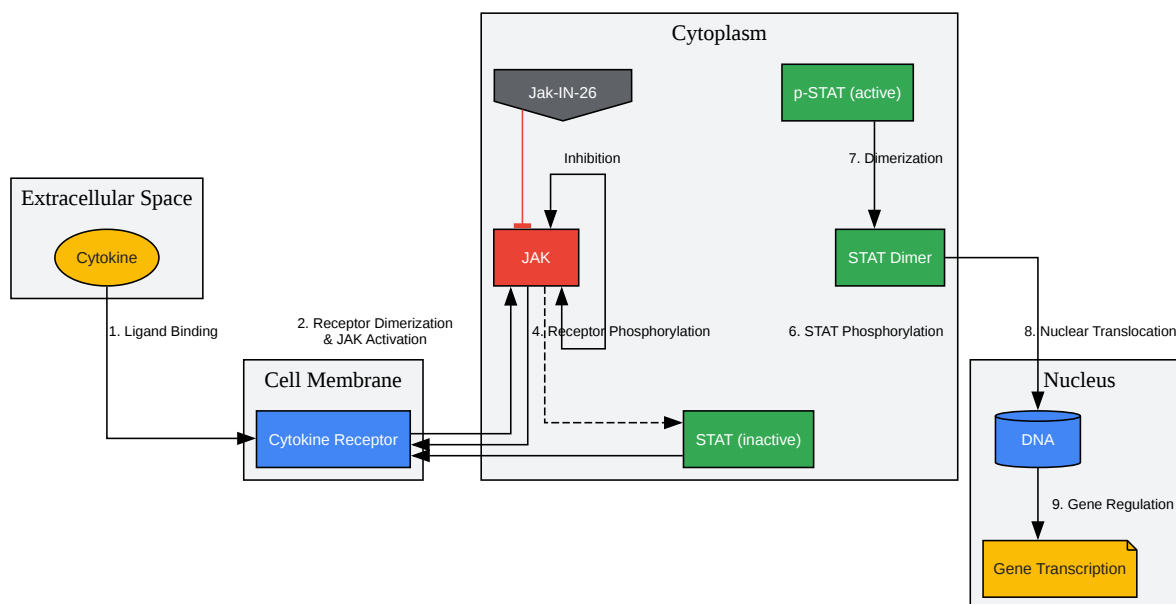

[Click to download full resolution via product page](#)

Caption: The JAK-STAT signaling pathway and the point of inhibition by **Jak-IN-26**.

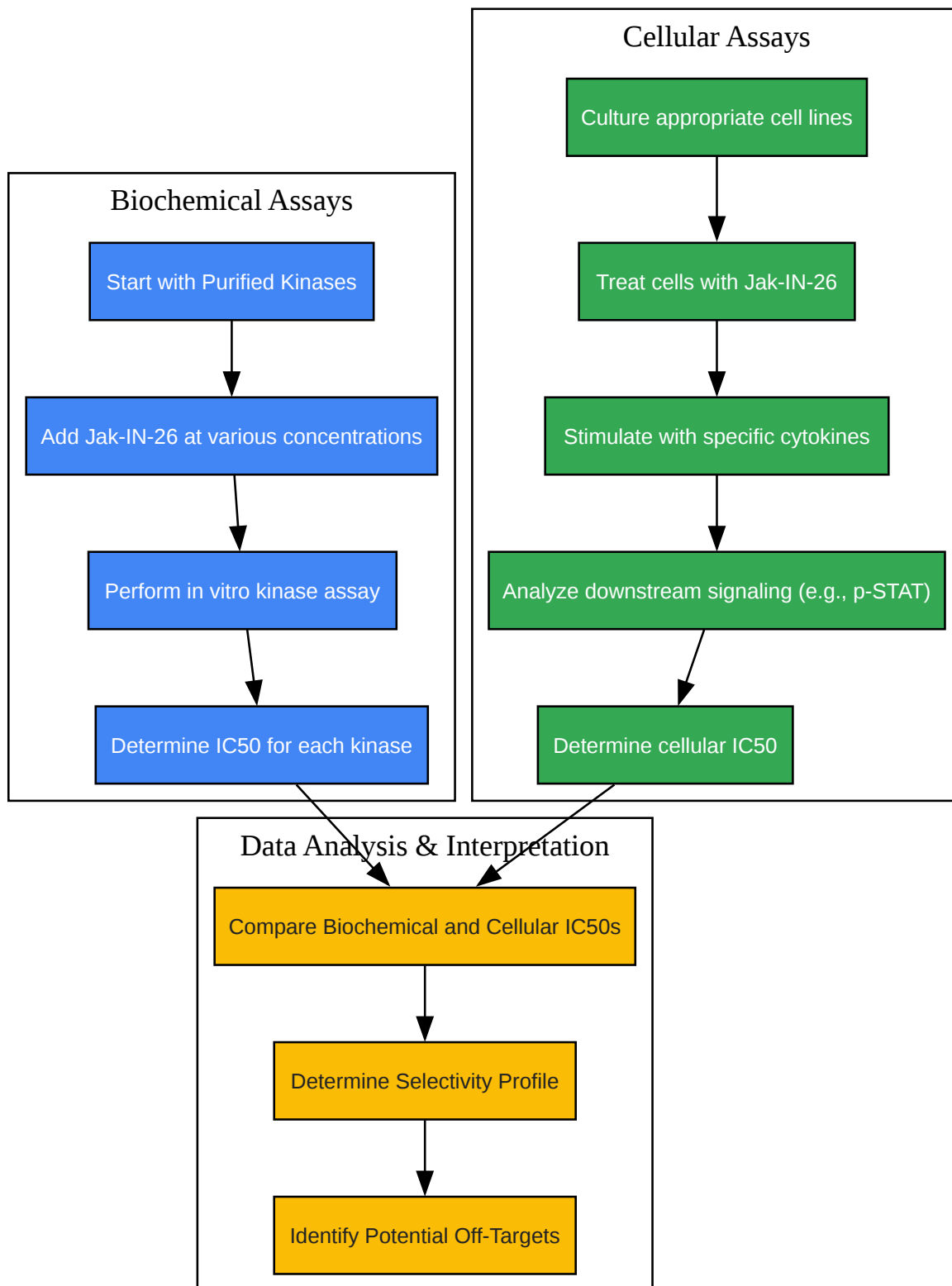

[Click to download full resolution via product page](#)

Caption: Experimental workflow for assessing the selectivity and off-target effects of **Jak-IN-26**.

Need Custom Synthesis?

BenchChem offers custom synthesis for rare earth carbides and specific isotopic labeling.

Email: info@benchchem.com or [Request Quote Online](#).

References

- [1. Basic Mechanisms of JAK Inhibition - PMC \[pmc.ncbi.nlm.nih.gov\]](#)
- [2. JAK inhibitor selectivity: new opportunities, better drugs? - PubMed \[pubmed.ncbi.nlm.nih.gov\]](#)
- [3. JAK inhibition as a therapeutic strategy for immune and inflammatory diseases - PMC \[pmc.ncbi.nlm.nih.gov\]](#)
- [4. The arrival of JAK inhibitors: advancing the treatment of immune and hematologic disorders - PMC \[pmc.ncbi.nlm.nih.gov\]](#)
- [5. researchgate.net \[researchgate.net\]](#)
- [6. Identification of novel off targets of baricitinib and tofacitinib by machine learning with a focus on thrombosis and viral infection - PubMed \[pubmed.ncbi.nlm.nih.gov\]](#)
- [7. Off-Target Effects of BCR-ABL and JAK2 Inhibitors - PubMed \[pubmed.ncbi.nlm.nih.gov\]](#)
- [8. jakafi.com \[jakafi.com\]](#)
- [9. JAK Inhibitors for Rheumatoid Arthritis \[webmd.com\]](#)
- [10. Potential Adverse Events Reported With the Janus Kinase Inhibitors Approved for the Treatment of Rheumatoid Arthritis Using Spontaneous Reports and Online Patient Reviews - PMC \[pmc.ncbi.nlm.nih.gov\]](#)
- [11. hcplive.com \[hcplive.com\]](#)
- [12. pubs.acs.org \[pubs.acs.org\]](#)
- [13. JAK selectivity and the implications for clinical inhibition of pharmacodynamic cytokine signalling by filgotinib, upadacitinib, tofacitinib and baricitinib - PMC \[pmc.ncbi.nlm.nih.gov\]](#)
- [14. Selectivity, efficacy and safety of JAKinibs: new evidence for a still evolving story | Annals of the Rheumatic Diseases \[ard.bmj.com\]](#)
- [15. selleckchem.com \[selleckchem.com\]](#)

- To cite this document: BenchChem. [Potential off-target effects of Jak-IN-26]. BenchChem, [2026]. [Online PDF]. Available at: [\[https://www.benchchem.com/product/b12385350/docs#potential-off-target-effects-of-jak-in-26\]](https://www.benchchem.com/product/b12385350/docs#potential-off-target-effects-of-jak-in-26)

Disclaimer & Data Validity:

The information provided in this document is for Research Use Only (RUO) and is strictly not intended for diagnostic or therapeutic procedures. While BenchChem strives to provide accurate protocols, we make no warranties, express or implied, regarding the fitness of this product for every specific experimental setup.

Technical Support: The protocols provided are for reference purposes. Unsure if this reagent suits your experiment?

Need Industrial/Bulk Grade? [Request Custom Synthesis Quote](#)

BenchChem

Our mission is to be the trusted global source of essential and advanced chemicals, empowering scientists and researchers to drive progress in science and industry.

Contact

Address: 3281 E Guasti Rd
Ontario, CA 91761, United States
Phone: (601) 213-4426
Email: info@benchchem.com

[Contact our Ph.D. Support Team for a compatibility check](#)