

Cell line-specific sensitivity to pan-KRAS-IN-9

Author: BenchChem Technical Support Team. **Date:** April 2026

Compound of Interest

Compound Name: *pan-KRAS-IN-9*

Cat. No.: *B12385920*

[Get Quote](#)

Technical Support Center: pan-KRAS-IN-9

Welcome to the technical support center for **pan-KRAS-IN-9**. This resource is designed to assist researchers, scientists, and drug development professionals in effectively utilizing this pan-KRAS inhibitor in their experiments. Below you will find troubleshooting guides, frequently asked questions (FAQs), detailed experimental protocols, and key data on cell line sensitivity.

Troubleshooting Guide

This section addresses common issues that may arise during experiments with **pan-KRAS-IN-9**.

Issue	Possible Cause	Suggested Solution
<p>Inconsistent IC50 values across experiments</p>	<p>1. Cell passage number variability. 2. Differences in serum concentration in the culture medium. 3. Inconsistent cell seeding density. 4. Degradation of the inhibitor.</p>	<p>1. Use cells within a consistent and low passage number range. 2. Maintain a consistent serum percentage throughout all experiments, as serum deprivation can enhance the inhibitor's effect.^[1] 3. Ensure uniform cell seeding density across all wells and plates. 4. Aliquot the inhibitor upon receipt and store at the recommended temperature. Avoid repeated freeze-thaw cycles.</p>
<p>Low or no observed inhibition of KRAS downstream signaling (e.g., p-ERK, p-AKT)</p>	<p>1. Insufficient incubation time. 2. Rebound activation of the pathway. 3. Incorrect protein extraction or Western blot procedure.</p>	<p>1. Optimize the incubation time. Short-term (e.g., 3 hours) treatment may show initial inhibition.^[2] 2. Be aware of potential feedback regulation that can lead to a rebound in signaling after prolonged incubation (e.g., 48-72 hours).^[2] 3. Review your lysis buffer composition, and ensure the use of fresh phosphatase and protease inhibitors. Confirm antibody specificity and optimal dilution.</p>
<p>High toxicity in KRAS wild-type (WT) cell lines</p>	<p>1. Off-target effects at high concentrations. 2. Functional redundancy of other RAS isoforms (HRAS, NRAS) is not compensating.^[3]</p>	<p>1. Perform a dose-response curve to determine the optimal concentration with minimal toxicity in relevant KRAS WT control cells. 2. Consider knockdown experiments for HRAS and NRAS to</p>

investigate potential synthetic lethality.[3]

Variability between 2D and 3D cell culture models

Cellular context and drug penetration can differ significantly.

Be aware that drug sensitivity can vary between 2D monolayer and 3D spheroid cultures.[2] Optimize inhibitor concentration and treatment duration specifically for your 3D model system.

Frequently Asked Questions (FAQs)

Q1: What is the mechanism of action of **pan-KRAS-IN-9** and similar pan-KRAS inhibitors?

A1: **Pan-KRAS-IN-9** and other pan-KRAS inhibitors, such as BI-2865, typically function by non-covalently binding to the inactive, GDP-bound "OFF" state of the KRAS protein.[3][4] This binding event blocks the nucleotide exchange process, preventing KRAS from becoming activated by guanine nucleotide exchange factors (GEFs) like SOS1.[2][3] By locking KRAS in its inactive state, these inhibitors prevent downstream signaling through pathways like MAPK (RAF-MEK-ERK) and PI3K-AKT, which are crucial for cell proliferation, growth, and survival.[3][5]

Q2: Which KRAS mutations are sensitive to this class of inhibitors?

A2: Pan-KRAS inhibitors are designed to be effective against a broad range of KRAS mutations. For instance, the inhibitor BI-2865 has demonstrated activity against mutants including G12A, G12C, G12D, G12F, G12V, G12S, G13C, G13D, Q61H, and A146T, among others.[3] The core mechanism of preventing nucleotide exchange allows them to be effective irrespective of many specific mutations that impair GTPase activity.[6]

Q3: Are KRAS wild-type (WT) cells sensitive to pan-KRAS inhibitors?

A3: Generally, cancer cells with mutant KRAS show higher sensitivity to pan-KRAS inhibitors than KRAS WT cells.[3] This is because mutant KRAS can create a dependency on continuous signaling through this pathway.[3] However, KRAS WT-amplified cancer cell lines, particularly those with a high copy number, have also been identified as being highly sensitive to pan-

KRAS inhibitors like BI-2493 and BI-2865.[4][7] In normal cells, functional redundancy from other RAS isoforms like HRAS and NRAS may compensate for KRAS inhibition.[3]

Q4: What is a typical starting concentration for in vitro experiments?

A4: Based on published data for similar pan-KRAS inhibitors, IC50 values can range from the low nanomolar to the micromolar range, depending on the cell line and assay conditions. For initial experiments, a dose-response curve ranging from 1 nM to 10 μ M is recommended to determine the effective concentration for your specific cell line of interest.

Cell Line-Specific Sensitivity to Pan-KRAS Inhibitors

The following table summarizes the half-maximal inhibitory concentration (IC50) values of various pan-KRAS inhibitors across different cancer cell lines.

Inhibitor	Cell Line	Cancer Type	KRAS Mutation	IC50 (nM)	Reference
pan-KRAS-IN-9	AsPC-1	Pancreatic	G12D	0.24	[8]
pan-KRAS-IN-9	SW480	Colorectal	G12V	0.30	[8]
BAY-293	PANC-1	Pancreatic	G12D	~950	[2]
BAY-293	MIA PaCa-2	Pancreatic	G12C	~6640	[2]
BAY-293	SW480	Colorectal	G12V	~1150	[2]
BI-2852	HCT 116	Colorectal	G13D	>100,000	[2]
BI-2852	PANC-1	Pancreatic	G12D	~18,830	[2]

Note: Experimental conditions such as serum concentration and assay duration can significantly impact IC50 values.

Experimental Protocols

Cell Viability Assay (e.g., CellTiter-Glo®)

This protocol is for assessing the effect of **pan-KRAS-IN-9** on the viability of adherent cancer cell lines in a 96-well format.

Materials:

- Target cancer cell lines
- Complete growth medium (e.g., DMEM/RPMI + 10% FBS)
- **Pan-KRAS-IN-9** (dissolved in DMSO)
- 96-well clear-bottom, opaque-walled plates
- CellTiter-Glo® Luminescent Cell Viability Assay kit
- Luminometer

Procedure:

- **Cell Seeding:** Trypsinize and count cells. Seed the cells in a 96-well plate at a predetermined optimal density (e.g., 2,000-5,000 cells/well) in 100 µL of complete growth medium. Incubate overnight at 37°C, 5% CO₂.
- **Compound Preparation:** Prepare a serial dilution of **pan-KRAS-IN-9** in complete growth medium. It is recommended to perform a 10-point dilution series. Include a DMSO-only vehicle control.
- **Treatment:** Carefully remove the medium from the wells and add 100 µL of the medium containing the different concentrations of the inhibitor or vehicle control.
- **Incubation:** Incubate the plate for the desired treatment period (e.g., 72-96 hours) at 37°C, 5% CO₂.
- **Assay:**
 - Equilibrate the plate and the CellTiter-Glo® reagent to room temperature for 30 minutes.
 - Add 100 µL of CellTiter-Glo® reagent to each well.

- Mix the contents on an orbital shaker for 2 minutes to induce cell lysis.
- Incubate at room temperature for 10 minutes to stabilize the luminescent signal.
- Data Acquisition: Measure the luminescence using a plate-reading luminometer.
- Analysis: Normalize the data to the vehicle control wells and plot the dose-response curve to calculate the IC50 value.

Western Blot for KRAS Signaling Pathway Analysis

This protocol outlines the steps to analyze the phosphorylation status of key downstream effectors of KRAS, such as ERK and AKT.

Materials:

- Target cancer cell lines
- 6-well plates
- **Pan-KRAS-IN-9** (dissolved in DMSO)
- RIPA Lysis Buffer supplemented with protease and phosphatase inhibitors
- BCA Protein Assay Kit
- SDS-PAGE gels and running buffer
- Transfer buffer and PVDF membrane
- Blocking buffer (e.g., 5% BSA or non-fat milk in TBST)
- Primary antibodies (e.g., anti-p-ERK, anti-ERK, anti-p-AKT, anti-AKT, anti-GAPDH)
- HRP-conjugated secondary antibodies
- Enhanced Chemiluminescence (ECL) substrate

Procedure:

- Cell Culture and Treatment: Seed cells in 6-well plates and allow them to adhere overnight. Treat the cells with the desired concentrations of **pan-KRAS-IN-9** or vehicle control for the specified time (e.g., 3, 24, 48 hours).
- Protein Extraction:
 - Wash cells twice with ice-cold PBS.
 - Add an appropriate volume of ice-cold RIPA buffer to each well and scrape the cells.
 - Incubate the lysate on ice for 30 minutes, vortexing occasionally.
 - Centrifuge at 14,000 rpm for 15 minutes at 4°C. Collect the supernatant.
- Protein Quantification: Determine the protein concentration of each lysate using a BCA assay.
- SDS-PAGE and Transfer:
 - Normalize the protein amounts and prepare samples with Laemmli buffer. Boil for 5 minutes.
 - Load equal amounts of protein onto an SDS-PAGE gel and run the electrophoresis.
 - Transfer the separated proteins to a PVDF membrane.
- Immunoblotting:
 - Block the membrane with blocking buffer for 1 hour at room temperature.
 - Incubate the membrane with the primary antibody (e.g., anti-p-ERK) overnight at 4°C, following the manufacturer's recommended dilution.
 - Wash the membrane three times with TBST.
 - Incubate with the appropriate HRP-conjugated secondary antibody for 1 hour at room temperature.

- Wash the membrane three times with TBST.
- Detection: Apply ECL substrate to the membrane and visualize the protein bands using a chemiluminescence imaging system.
- Stripping and Re-probing: If necessary, strip the membrane and re-probe with antibodies for total protein (e.g., total ERK) and a loading control (e.g., GAPDH) to ensure equal protein loading.

Visualizations

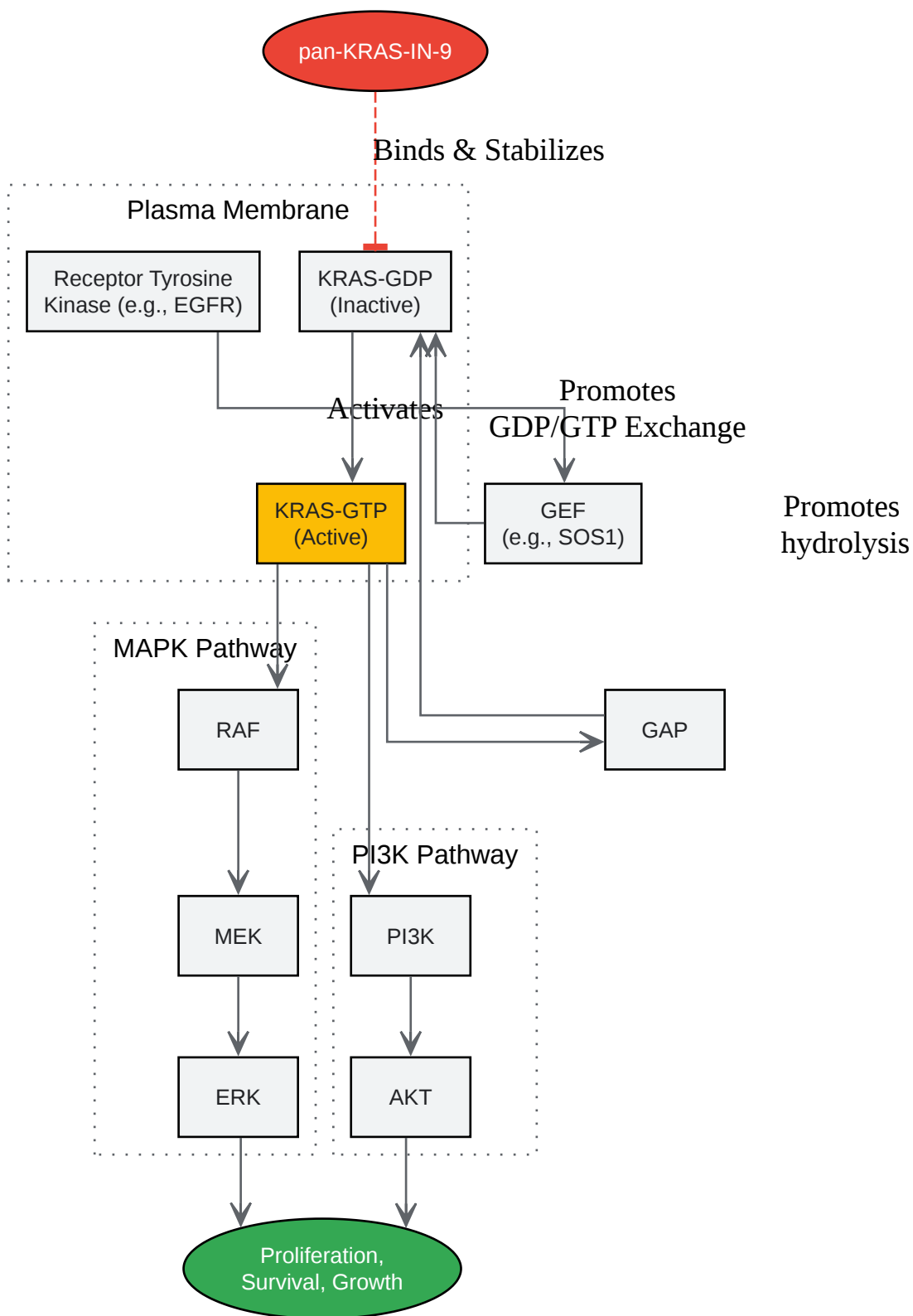

[Click to download full resolution via product page](#)

Caption: Mechanism of **pan-KRAS-IN-9** on the KRAS signaling pathway.

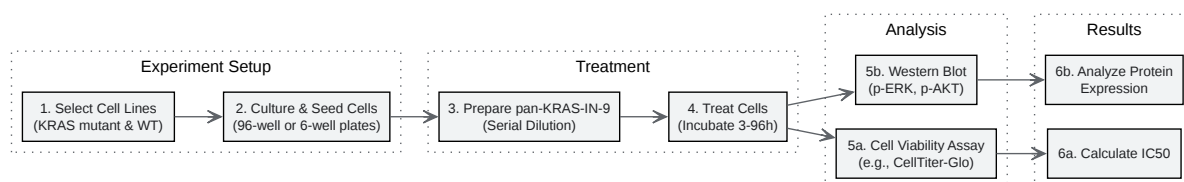

[Click to download full resolution via product page](#)

Caption: General workflow for in vitro testing of **pan-KRAS-IN-9**.

Need Custom Synthesis?

BenchChem offers custom synthesis for rare earth carbides and specific isotopic labeling.

Email: info@benchchem.com or [Request Quote Online](#).

References

- [1. resources.revvity.com \[resources.revvity.com\]](https://resources.revvity.com)
- [2. Pan-KRAS inhibitors suppress proliferation through feedback regulation in pancreatic ductal adenocarcinoma - PMC \[pmc.ncbi.nlm.nih.gov\]](https://pubmed.ncbi.nlm.nih.gov/20111111/)
- [3. KRAS: Biology, Inhibition, and Mechanisms of Inhibitor Resistance - PMC \[pmc.ncbi.nlm.nih.gov\]](https://pubmed.ncbi.nlm.nih.gov/20111111/)
- [4. aacrjournals.org \[aacrjournals.org\]](https://aacrjournals.org)
- [5. A Pan-RAS Inhibitor with a Unique Mechanism of Action Blocks Tumor Growth and Induces Antitumor Immunity in Gastrointestinal Cancer - PubMed \[pubmed.ncbi.nlm.nih.gov\]](https://pubmed.ncbi.nlm.nih.gov/20111111/)
- [6. Pan-KRAS inhibitor disables oncogenic signalling and tumour growth - PubMed \[pubmed.ncbi.nlm.nih.gov\]](https://pubmed.ncbi.nlm.nih.gov/20111111/)
- [7. Pan-KRAS Inhibitors BI-2493 and BI-2865 Display Potent Antitumor Activity in Tumors with KRAS Wild-type Allele Amplification - PMC \[pmc.ncbi.nlm.nih.gov\]](https://pubmed.ncbi.nlm.nih.gov/20111111/)
- [8. medchemexpress.com \[medchemexpress.com\]](https://medchemexpress.com)

- To cite this document: BenchChem. [Cell line-specific sensitivity to pan-KRAS-IN-9]. BenchChem, [2026]. [Online PDF]. Available at: [<https://www.benchchem.com/product/b12385920/docs#cell-line-specific-sensitivity-to-pan-kras-in-9>]

Disclaimer & Data Validity:

The information provided in this document is for Research Use Only (RUO) and is strictly not intended for diagnostic or therapeutic procedures. While BenchChem strives to provide accurate protocols, we make no warranties, express or implied, regarding the fitness of this product for every specific experimental setup.

Technical Support: The protocols provided are for reference purposes. Unsure if this reagent suits your experiment?

Need Industrial/Bulk Grade? [Request Custom Synthesis Quote](#)

BenchChem

Our mission is to be the trusted global source of essential and advanced chemicals, empowering scientists and researchers to drive progress in science and industry.

Contact

Address: 3281 E Guasti Rd
Ontario, CA 91761, United States
Phone: (601) 213-4426
Email: info@benchchem.com

[Contact our Ph.D. Support Team for a compatibility check](#)