

Application Notes and Protocols for PF-07208254 Administration in Mice

Author: BenchChem Technical Support Team. **Date:** April 2026

Compound of Interest

Compound Name: PF-07208254

Cat. No.: B12385626

[Get Quote](#)

These application notes provide detailed protocols for the dosing and administration of **PF-07208254**, a selective, orally active allosteric inhibitor of branched-chain ketoacid dehydrogenase kinase (BDK), in mouse models. This document is intended for researchers, scientists, and drug development professionals investigating the role of BDK in cardiometabolic diseases.

Mechanism of Action

PF-07208254 functions by selectively inhibiting BDK, a key enzyme that negatively regulates the branched-chain ketoacid dehydrogenase (BCKDH) complex. By inhibiting BDK, **PF-07208254** prevents the phosphorylation of BCKDH, thereby enhancing the catabolism of branched-chain amino acids (BCAAs) and branched-chain keto acids (BCKAs).[1][2] This mechanism of action makes **PF-07208254** a valuable tool for studying the therapeutic potential of modulating BCAA metabolism in conditions such as heart failure and type 2 diabetes.[1]

Data Presentation: In Vivo Dosing in Mice

The following table summarizes the quantitative data from preclinical studies involving the administration of **PF-07208254** to mice.

Parameter	Details	Reference
Animal Model	C57BL6/J mice with diet-induced obesity (HFD)	[1]
16-week-old male C57BL6/J mice	[1]	
Mice subjected to transverse aortic constriction (TAC) surgery	[3][4]	
Dose(s)	30 mg/kg, 90 mg/kg	[1]
Administration Route	Oral gavage, Medicated chow	[1][3][4]
Frequency	Once daily	[1]
Duration	8 weeks	[1]
8 days (for BCAA/BCKA lowering)	[3]	
Started 48 hours prior to TAC surgery and continued for 5-6 weeks	[3][4]	
Vehicle/Formulation	For Oral Gavage (2.5 mg/mL): 10% DMSO, 40% PEG300, 5% Tween-80, 45% Saline	[1]
Observed Effects	- Reduced blood glucose area under the curve (AUC) in an oral glucose tolerance test (oGTT).	[1]
- Reduced inflammatory and fibrotic gene expression in the liver.	[1]	
- Reduced fasting insulin levels.	[1]	

- Dose- and time-dependently reduced BCAA and BCKA levels in plasma and muscle. [1][3]

- Improved cardiac function (e.g., % Fractional shortening, % Ejection fraction) in a TAC mouse model of heart failure. [3][4]

Experimental Protocols

Protocol 1: Oral Gavage Administration in a Diet-Induced Obesity (DIO) Mouse Model

This protocol details the once-daily oral gavage administration of **PF-07208254** to C57BL6/J mice with diet-induced obesity.

Materials:

- **PF-07208254** powder
- Dimethyl sulfoxide (DMSO)
- Polyethylene glycol 300 (PEG300)
- Tween-80
- Saline solution (0.9% NaCl)
- 1.5 mL microcentrifuge tubes
- Vortex mixer
- Animal feeding needles (gavage needles)
- Syringes (1 mL)
- Male C57BL6/J mice (16 weeks old) on a high-fat diet

Procedure:

- Formulation Preparation (2.5 mg/mL solution):
 - Prepare a 25.0 mg/mL stock solution of **PF-07208254** in DMSO.
 - To prepare 1 mL of the final working solution, add 100 μ L of the DMSO stock solution to 400 μ L of PEG300 in a 1.5 mL microcentrifuge tube.
 - Mix thoroughly by vortexing.
 - Add 50 μ L of Tween-80 and vortex again until the solution is homogenous.
 - Add 450 μ L of saline to bring the final volume to 1 mL. The final concentration will be 2.5 mg/mL.[1]
 - This formulation should result in a clear solution. It is recommended to prepare this formulation fresh. For studies lasting over two weeks, careful consideration of formulation stability is advised.[1]
- Dosing:
 - Acclimatize the mice to handling and the gavage procedure for several days before the start of the experiment.
 - Calculate the required volume for each mouse based on its body weight and the target dose (30 mg/kg or 90 mg/kg). For example, for a 25g mouse at a 30 mg/kg dose, the volume would be 0.3 mL of the 2.5 mg/mL solution.
 - Administer the calculated volume of the **PF-07208254** formulation or vehicle control to the mice once daily via oral gavage.
 - The study duration for this protocol is typically 8 weeks.[1]

Protocol 2: Administration via Medicated Chow in a Transverse Aortic Constriction (TAC) Mouse Model

This protocol describes the administration of **PF-07208254** mixed into rodent chow for studies involving surgically induced heart failure.

Materials:

- **PF-07208254** powder
- Standard rodent chow
- Food processor or mixer
- Male C57BL6/J mice
- Surgical equipment for TAC procedure

Procedure:

- Medicated Chow Preparation:
 - The specific concentration of **PF-07208254** in the chow will depend on the desired daily dose and the average daily food consumption of the mice. This needs to be determined empirically.
 - Thoroughly mix the calculated amount of **PF-07208254** powder with the powdered or crushed standard rodent chow to ensure a homogenous distribution.
 - The medicated chow can then be provided to the mice as their sole food source.
- Dosing and Study Timeline:
 - Begin feeding the mice with the **PF-07208254**-containing chow or control chow 48 hours prior to the TAC surgery.^{[3][4]}
 - Perform the TAC surgery to induce cardiac pressure overload.
 - Continue the medicated diet for the duration of the study, which is typically 5 to 6 weeks post-surgery.^{[3][4]}

- Monitor cardiac function using methods such as echocardiography at specified time points (e.g., 4 weeks post-surgery).[3][4]

Visualizations

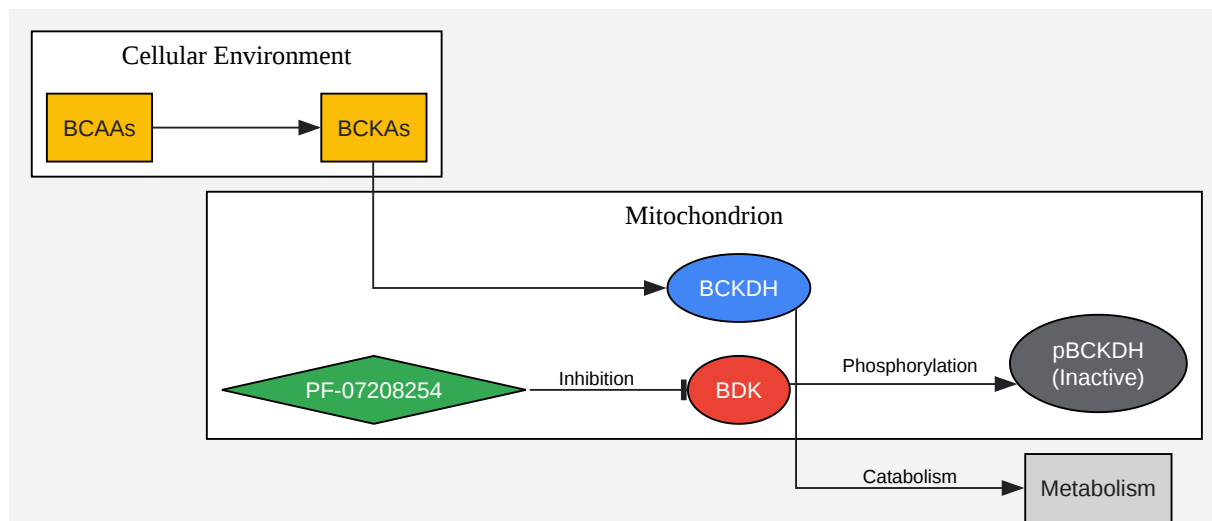

[Click to download full resolution via product page](#)

Caption: Signaling pathway of **PF-07208254** action.

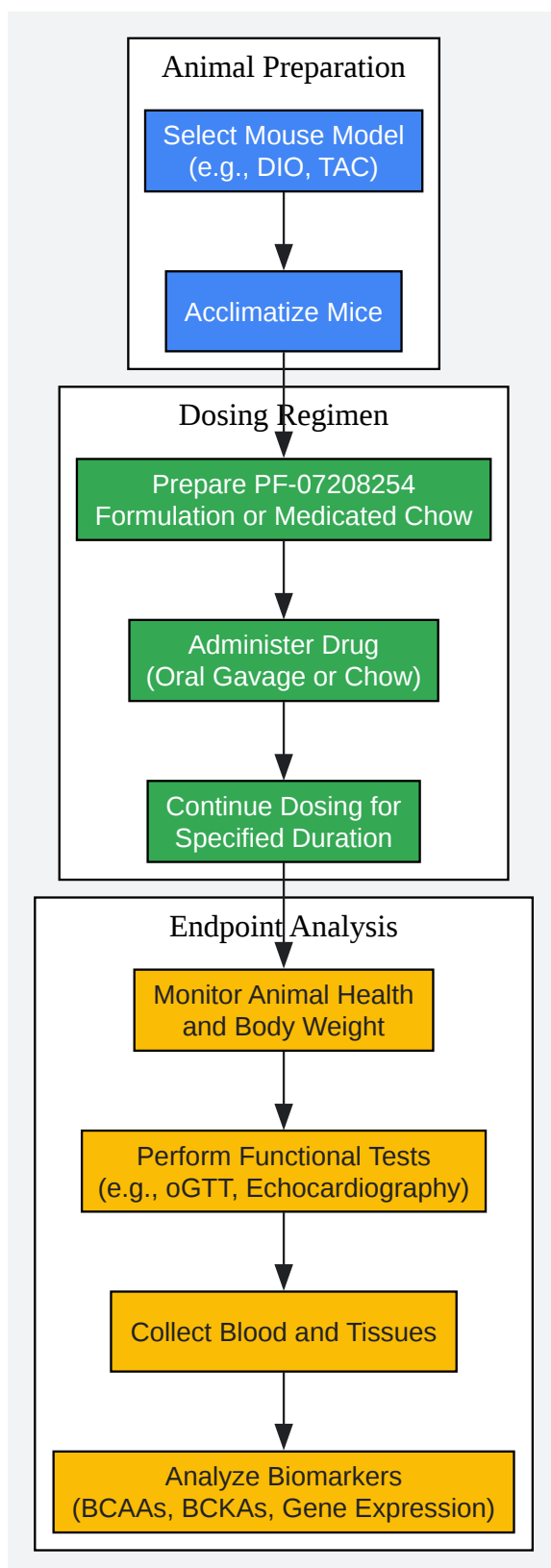

[Click to download full resolution via product page](#)

Caption: General experimental workflow for in vivo studies.

Need Custom Synthesis?

BenchChem offers custom synthesis for rare earth carbides and specific isotopic labeling.

Email: info@benchchem.com or [Request Quote Online](#).

References

- [1. medchemexpress.com \[medchemexpress.com\]](https://www.medchemexpress.com)
- [2. Small molecule branched-chain ketoacid dehydrogenase kinase \(BDK\) inhibitors with opposing effects on BDK protein levels - PubMed \[pubmed.ncbi.nlm.nih.gov\]](#)
- [3. Small molecule branched-chain ketoacid dehydrogenase kinase \(BDK\) inhibitors with opposing effects on BDK protein levels - PMC \[pmc.ncbi.nlm.nih.gov\]](#)
- [4. researchgate.net \[researchgate.net\]](https://www.researchgate.net)
- To cite this document: BenchChem. [Application Notes and Protocols for PF-07208254 Administration in Mice]. BenchChem, [2026]. [Online PDF]. Available at: [\[https://www.benchchem.com/product/b12385626/docs#application-notes-and-protocols-for-pf-07208254-administration-in-mice\]](https://www.benchchem.com/product/b12385626/docs#application-notes-and-protocols-for-pf-07208254-administration-in-mice)

Disclaimer & Data Validity:

The information provided in this document is for Research Use Only (RUO) and is strictly not intended for diagnostic or therapeutic procedures. While BenchChem strives to provide accurate protocols, we make no warranties, express or implied, regarding the fitness of this product for every specific experimental setup.

Technical Support: The protocols provided are for reference purposes. Unsure if this reagent suits your experiment?

Need Industrial/Bulk Grade? [Request Custom Synthesis Quote](#)

BenchChem

Our mission is to be the trusted global source of essential and advanced chemicals, empowering scientists and researchers to drive progress in science and industry.

Contact

Address: 3281 E Guasti Rd

Ontario, CA 91761, United States

Phone: (601) 213-4426

Email: info@benchchem.com

[Contact our Ph.D. Support Team for a compatibility check](#)