

Application Notes: In Vitro Characterization of PF-07208254 in Human Skeletal Muscle Cells

Author: BenchChem Technical Support Team. **Date:** April 2026

Compound of Interest

Compound Name: PF-07208254

Cat. No.: B12385626

[Get Quote](#)

Introduction

PF-07208254 is a potent and selective allosteric inhibitor of branched-chain ketoacid dehydrogenase kinase (BDK).[1][2] BDK is a key regulatory enzyme in the catabolism of branched-chain amino acids (BCAAs), which include leucine, isoleucine, and valine.[3] BDK phosphorylates and inactivates the branched-chain ketoacid dehydrogenase (BCKDH) complex, the rate-limiting enzyme in BCAA degradation.[2][3] By inhibiting BDK, **PF-07208254** prevents the inactivation of BCKDH, thereby promoting the breakdown of BCAAs and their corresponding ketoacids (BCKAs).[1][4]

Elevated levels of BCAAs and BCKAs are associated with insulin resistance and other metabolic disorders.[4][5] Skeletal muscle is a primary site for BCAA catabolism, making it a critical tissue for studying the effects of BDK inhibitors.[6] In vitro assays using human skeletal muscle cells, such as primary myoblasts differentiated into myotubes, provide a relevant physiological model to investigate the cellular potency and mechanism of action of compounds like **PF-07208254**. [7] These models allow for the direct assessment of the compound's effect on BCAA pathway targets and downstream metabolic processes like insulin signaling and glucose uptake.[4][7]

Mechanism of Action

PF-07208254 binds to an allosteric inhibitory pocket within the BDK regulatory domain.[1] This binding prevents BDK from phosphorylating the E1 α subunit of the BCKDH complex. As a result, the BCKDH complex remains active, leading to increased catabolism of BCAAs.[1][3] Studies have shown that this enhanced BCAA breakdown can lead to a reduction in intracellular and circulating levels of BCAAs and BCKAs.[1] Furthermore, by modulating BCAA metabolism, **PF-07208254** can influence insulin sensitivity and glucose metabolism in skeletal muscle cells.[4]

Quantitative Data Summary

The potency of **PF-07208254** has been characterized in various in vitro assays, including biochemical assays, binding assays, and cell-based assays using human skeletal myocytes.

Assay Type	Parameter	Value (nM)	Reference
BDK In Vitro Functional Assay	Ki	54 \pm 3.1	[1]
BDK In Vitro Functional Assay	IC50	110 \pm 6.9	[1]
Surface Plasmon Resonance (SPR)	Kd	84 \pm 8.7	[1]
Human Skeletal Myocyte Assay (pBCKDH)	Cellular IC50	540 \pm 140	[1][2]

Visualized Signaling Pathways and Workflows

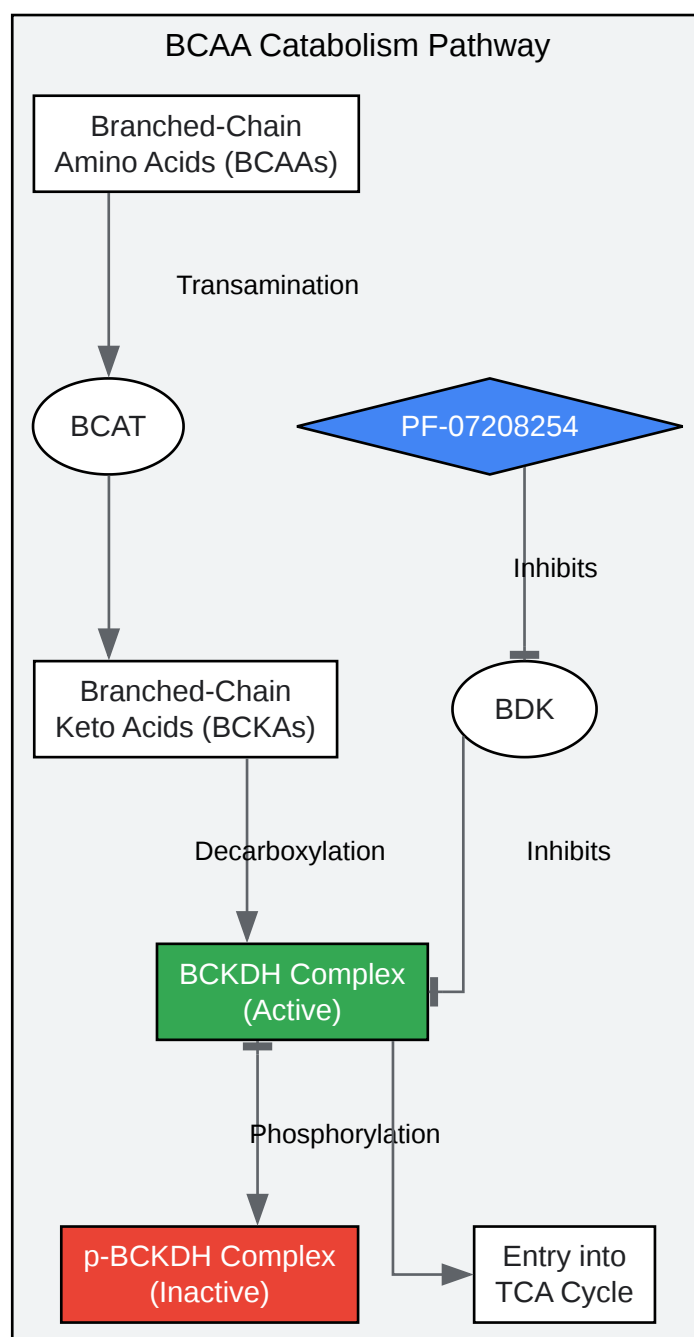

[Click to download full resolution via product page](#)

Caption: BCAA catabolism pathway and the inhibitory action of **PF-07208254** on BDK.

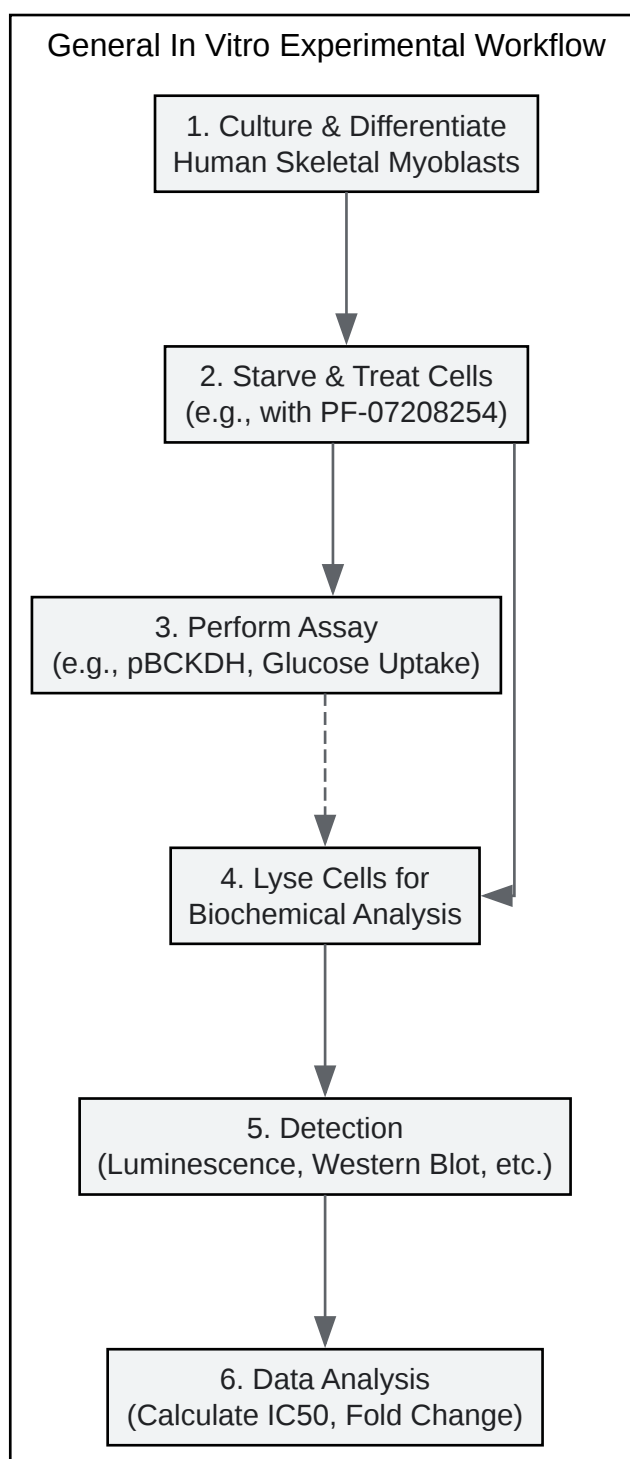

[Click to download full resolution via product page](#)

Caption: A generalized workflow for in vitro assays in human skeletal muscle cells.

Experimental Protocols

Protocol 1: Culture and Differentiation of Human Skeletal Myoblasts

This protocol describes the standard procedure for culturing human primary skeletal myoblasts and inducing their differentiation into multinucleated myotubes, which represent a mature muscle fiber phenotype.

Materials:

- Human Skeletal Myoblasts
- Skeletal Muscle Cell Growth Medium (e.g., SkGM™ BulletKit™)
- Differentiation Medium (DM): DMEM supplemented with 2% horse serum and 1% Penicillin-Streptomycin.
- Fibronectin-coated culture plates
- DPBS (Dulbecco's Phosphate-Buffered Saline)

Procedure:

- Plating Myoblasts:
 1. Pre-coat culture plates with fibronectin solution (10 µg/ml) for at least 1 hour at 37°C.[8]
 2. Aspirate the coating solution and plate the human skeletal myoblasts in growth medium at a density of 1.5×10^4 cells/cm².
 3. Incubate at 37°C in a humidified atmosphere of 5% CO₂.
- Proliferation:
 1. Change the growth medium every 2-3 days until the cells reach approximately 80-90% confluency. Do not allow cells to become fully confluent as this can impair differentiation.
- Differentiation:

1. When cells reach the target confluency, aspirate the growth medium.
2. Wash the cells twice with sterile DPBS.
3. Add Differentiation Medium (DM) to the culture plate.
4. Incubate the cells for 5-7 days to allow for fusion and differentiation into myotubes. Change the DM every 2 days.[7] Successful differentiation is characterized by the formation of elongated, multinucleated myotubes.

Protocol 2: BCKDH Phosphorylation Immunoassay in Myotubes

This protocol outlines a method to quantify the inhibitory effect of **PF-07208254** on BDK activity by measuring the phosphorylation of its direct substrate, BCKDH, in human skeletal myotubes. An AlphaLISA® SureFire® Ultra™ assay is cited as a suitable high-throughput method.[1]

Materials:

- Differentiated human myotubes in 96-well plates
- **PF-07208254** stock solution (in DMSO)
- Serum-free culture medium
- Lysis buffer (provided with immunoassay kit)
- AlphaLISA® detection reagents

Procedure:

- Cell Treatment:
 1. Prepare serial dilutions of **PF-07208254** in serum-free medium to achieve the desired final concentrations. Include a vehicle control (DMSO).
 2. Aspirate the differentiation medium from the myotubes.

3. Wash the cells once with warm DPBS.
 4. Add the medium containing the different concentrations of **PF-07208254** or vehicle control to the wells.
 5. Incubate for the desired time (e.g., 1-2 hours) at 37°C, 5% CO₂.
- Cell Lysis:
 1. Aspirate the treatment medium.
 2. Add the appropriate volume of lysis buffer to each well and incubate on an orbital shaker for 10-15 minutes at room temperature.
 - Immunoassay:
 1. Transfer the cell lysates to a 384-well ProxiPlate®.
 2. Add the AlphaLISA® acceptor beads and donor beads mixture according to the manufacturer's protocol. This mixture will typically contain antibodies specific for total and phosphorylated BCKDH.
 3. Incubate the plate in the dark at room temperature for 1-2 hours.
 - Data Acquisition:
 1. Read the plate on an EnVision® or a similar plate reader capable of AlphaScreen® detection.
 2. Calculate the ratio of the phospho-BCKDH signal to the total BCKDH signal.
 3. Plot the normalized signal against the log of the **PF-07208254** concentration and fit a dose-response curve to determine the cellular IC₅₀.

Protocol 3: Insulin-Stimulated Glucose Uptake Assay

This protocol measures the rate of glucose transport into myotubes and is a key functional assay to assess insulin sensitivity. The effect of **PF-07208254** on this process can be

evaluated.[\[7\]](#)[\[8\]](#)

Materials:

- Differentiated human myotubes in 24- or 48-well plates
- Krebs-Ringer-HEPES (KRH) buffer
- Insulin (100 nM final concentration)
- 2-deoxy-D-³H]glucose or a fluorescent glucose analog like 2-NBDG.[\[7\]](#)[\[9\]](#)
- Cytochalasin B (as a non-specific uptake inhibitor)
- Lysis buffer (e.g., 0.1 N NaOH)
- Scintillation fluid and counter (for radiolabeled glucose) or fluorescence plate reader.

Procedure:

- Pre-treatment with **PF-07208254**:
 1. Treat differentiated myotubes with the desired concentrations of **PF-07208254** or vehicle in serum-free medium for a specified period (e.g., 2-24 hours).
- Serum Starvation and Insulin Stimulation:
 1. Aspirate the treatment medium and wash the cells twice with warm DPBS.
 2. Incubate the cells in serum-free medium (e.g., DMEM without FCS) for 3 hours at 37°C for serum depletion.[\[7\]](#)
 3. Replace the medium with fresh serum-free medium. For insulin-stimulated conditions, add 100 nM insulin to the designated wells. For basal conditions, add vehicle.[\[7\]](#)
 4. Incubate for 1 hour at 37°C.[\[7\]](#)
- Glucose Uptake Measurement:

1. Wash the cells twice with KRH buffer to remove any remaining glucose.
 2. Add KRH buffer containing the glucose analog (e.g., [³H] 2-deoxy-D-Glucose). For control wells to measure non-specific uptake, also add cytochalasin B.[7][8]
 3. Incubate for 15-30 minutes at 37°C.[7]
 4. Stop the reaction by aspirating the uptake solution and immediately washing the cells three times with ice-cold DPBS.
- Cell Lysis and Detection:
 1. Lyse the cells by adding 0.1 N NaOH and shaking for 10 minutes.[10]
 2. Transfer a portion of the lysate for protein quantification (e.g., BCA assay).
 3. For radiolabeled glucose, transfer the remaining lysate to a scintillation vial, add scintillation fluid, and measure radioactivity using a scintillation counter.
 4. For fluorescent analogs, measure the fluorescence on a plate reader.
 - Data Analysis:
 1. Subtract the non-specific uptake (wells with cytochalasin B) from all other readings.
 2. Normalize the glucose uptake values to the protein concentration in each well.
 3. Calculate the fold change of insulin-stimulated uptake over basal for each treatment condition.

Need Custom Synthesis?

BenchChem offers custom synthesis for rare earth carbides and specific isotopic labeling.

Email: info@benchchem.com or [Request Quote Online](#).

References

- [1. Small molecule branched-chain ketoacid dehydrogenase kinase \(BDK\) inhibitors with opposing effects on BDK protein levels - PMC \[pmc.ncbi.nlm.nih.gov\]](#)
- [2. researchgate.net \[researchgate.net\]](#)
- [3. mdpi.com \[mdpi.com\]](#)
- [4. Depletion of Branched-Chain Ketoacid Dehydrogenase Kinase \(BDK\) Upregulates Insulin-Stimulated Glucose Uptake in Muscle Cells - PMC \[pmc.ncbi.nlm.nih.gov\]](#)
- [5. Effects of ketoisocaproic acid and inflammation on glucose transport in muscle cells - PubMed \[pubmed.ncbi.nlm.nih.gov\]](#)
- [6. PGC-1 \$\alpha\$ -Mediated Branched-Chain Amino Acid Metabolism in the Skeletal Muscle | PLOS One \[journals.plos.org\]](#)
- [7. Glucose Uptake Measurement and Response to Insulin Stimulation in In Vitro Cultured Human Primary Myotubes - PMC \[pmc.ncbi.nlm.nih.gov\]](#)
- [8. fujifilmcdi.com \[fujifilmcdi.com\]](#)
- [9. Efficient and modified 2-NBDG assay to measure glucose uptake in cultured myotubes - PubMed \[pubmed.ncbi.nlm.nih.gov\]](#)
- [10. journals.physiology.org \[journals.physiology.org\]](#)
- To cite this document: BenchChem. [Application Notes: In Vitro Characterization of PF-07208254 in Human Skeletal Muscle Cells]. BenchChem, [2026]. [Online PDF]. Available at: [<https://www.benchchem.com/product/b12385626/docs#application-notes-in-vitro-characterization-of-pf-07208254-in-human-skeletal-muscle-cells>]

Disclaimer & Data Validity:

The information provided in this document is for Research Use Only (RUO) and is strictly not intended for diagnostic or therapeutic procedures. While BenchChem strives to provide accurate protocols, we make no warranties, express or implied, regarding the fitness of this product for every specific experimental setup.

Technical Support: The protocols provided are for reference purposes. Unsure if this reagent suits your experiment?

Need Industrial/Bulk Grade? [Request Custom Synthesis Quote](#)

BenchChem

Our mission is to be the trusted global source of essential and advanced chemicals, empowering scientists and researchers to drive progress in science and industry.

Contact

Address: 3281 E Guasti Rd
Ontario, CA 91761, United States
Phone: (601) 213-4426
Email: info@benchchem.com

[Contact our Ph.D. Support Team for a compatibility check](#)