

interpreting unexpected outcomes in DRI-C21041 experiments

Author: BenchChem Technical Support Team. **Date:** April 2026

Compound of Interest

Compound Name: DRI-C21041

Cat. No.: B12384510

[Get Quote](#)

Technical Support Center: DRI-C21041 Experiments

This technical support center provides troubleshooting guidance and frequently asked questions (FAQs) for researchers, scientists, and drug development professionals working with **DRI-C21041**, a small-molecule inhibitor of the CD40-CD40L interaction.

Frequently Asked Questions (FAQs)

Q1: What is the primary mechanism of action for **DRI-C21041**?

A1: **DRI-C21041** is a small-molecule inhibitor that targets the interaction between CD40L (CD154) on activated T cells and CD40 on antigen-presenting cells (APCs), such as B cells, macrophages, and dendritic cells.[1][2] By binding to CD40L, **DRI-C21041** blocks this critical co-stimulatory signal, which is essential for T cell activation, B cell proliferation and differentiation, and cytokine production.[2][3] This inhibition leads to an immunosuppressive effect.[4]

Q2: In what experimental models has **DRI-C21041** shown efficacy?

A2: **DRI-C21041** has demonstrated significant efficacy in murine models of islet transplantation and autoimmune type 1 diabetes (T1D).[1][5] Specifically, it has been shown to prolong the survival of islet allografts in both kidney subcapsular and anterior chamber of the eye (ACE) transplantation models.[1] In female NOD mice, a model for T1D, treatment with **DRI-C21041** reduced the incidence of diabetes.[5][6]

Q3: What is the selectivity profile of **DRI-C21041**?

A3: **DRI-C21041** has been shown to be selective for the CD40-CD40L interaction. It exhibits greater than 30-fold selectivity against other TNF superfamily protein-protein interactions, including OX40-OX40L, BAFFR-BAFF, and TNF-R1–TNF α . [1]

Troubleshooting Guide for Unexpected Outcomes

Issue 1: Lower than expected efficacy in an in vivo model.

- Q: My in vivo experiment with **DRI-C21041** is showing minimal or no effect on the immune response. What are the potential causes?
 - A: Insufficient Dosing or Bioavailability: Ensure that the dosage and administration route are appropriate for your model. **DRI-C21041** has a reported half-life of approximately 10.8 hours in C57BL/6 mice when administered subcutaneously at 30 mg/kg.[1] Dosing frequency should be adjusted accordingly. For example, in islet allograft models, a twice-daily (b.i.d.) administration has been shown to be effective.[1]
 - A: Vehicle Formulation: The solubility and stability of **DRI-C21041** can be influenced by the vehicle. A 20% HP β CD (hydroxypropyl- β -cyclodextrin) solution has been successfully used for subcutaneous administration.[1] If you are using a different vehicle, consider performing a preliminary pharmacokinetic study to ensure adequate exposure.
 - A: Model-Specific Differences: The efficacy of **DRI-C21041** can vary between different experimental models and mouse strains. The immune response kinetics in your model may require an adjusted treatment window.

Issue 2: Inconsistent results in cell-based assays.

- Q: I am observing high variability in my IC50 values for **DRI-C21041** in an NF-κB reporter assay. What could be the cause?
 - A: Cell Passage Number and Health: Use cells with a consistent and low passage number. High passage numbers can lead to phenotypic drift and altered signaling responses. Ensure cells are healthy and have high viability before starting the assay.
 - A: Reagent Quality and Consistency: The activity of recombinant CD40L can vary between lots and suppliers. Qualify each new lot of CD40L to ensure consistent stimulation. Ensure the **DRI-C21041** stock solution is properly stored and has not undergone multiple freeze-thaw cycles.
 - A: Assay Timing: The timing of **DRI-C21041** pre-incubation and the duration of CD40L stimulation are critical. Optimize these parameters for your specific cell line to achieve a robust and reproducible assay window.

Issue 3: Potential off-target effects or cytotoxicity.

- Q: I am observing unexpected cell death in my cultures treated with **DRI-C21041**. Is this a known issue?
 - A: High Concentrations: While **DRI-C21041** has shown a lack of cytotoxicity at effective concentrations, very high doses may lead to off-target effects or cellular stress.^[4] It is crucial to perform a dose-response curve to determine the optimal concentration that provides efficacy without inducing cytotoxicity.
 - A: Solvent Toxicity: Ensure that the final concentration of the solvent (e.g., DMSO) in your cell culture media is non-toxic. It is recommended to keep the final DMSO concentration below 0.5%.
 - A: Cell Line Sensitivity: Different cell lines may have varying sensitivities to small-molecule inhibitors. It is advisable to run a standard cytotoxicity assay (e.g., MTT or LDH release) in parallel with your functional assays to monitor cell health.

Data Summary Tables

Table 1: In Vitro Activity of **DRI-C21041**

Assay Type	Cell Line / System	IC50 Value	Reference
CD40-CD40L Binding (ELISA)	Cell-free	87 nM	[1]
NF-κB Activation	NF-κB Biosensor Cells	10.3 μM	[1]
B-cell Activation	Primary Human B Lymphocytes	13.2 μM	[1]

Table 2: In Vivo Pharmacokinetics of **DRI-C21041**

Parameter	Value	Species	Dosing	Reference
Half-life (t1/2)	10.8 hours	C57BL/6 Mice	30 mg/kg, s.c.	[1]

Table 3: In Vivo Efficacy of **DRI-C21041** in Islet Allograft Models

Model	Treatment Regimen	Outcome	Reference
Anterior Chamber of the Eye (ACE)	12.5 mg/kg, b.i.d., s.c.	80% graft survival at day 115	[1]
Kidney Subcapsule	12.5 mg/kg, b.i.d., s.c.	~50% long-term graft survival	[1]

Experimental Protocols

Protocol 1: NF-κB Reporter Assay for **DRI-C21041** Activity

- Cell Culture: Culture NF-κB biosensor cells (e.g., HEK-Blue™ CD40L) according to the manufacturer's instructions.
- Cell Plating: Seed the cells in a 96-well plate at a density that allows for optimal growth during the assay period.

- **Compound Preparation:** Prepare a serial dilution of **DRI-C21041** in the appropriate vehicle (e.g., DMSO). Further dilute in cell culture medium to achieve the final desired concentrations.
- **Treatment:** Add the diluted **DRI-C21041** or vehicle control to the appropriate wells.
- **Stimulation:** After a pre-incubation period (e.g., 1 hour), add recombinant soluble CD40L to the wells to stimulate the cells. Include a non-stimulated control.
- **Incubation:** Incubate the plate for a predetermined period (e.g., 18-24 hours) at 37°C in a 5% CO₂ incubator.
- **Detection:** Measure the activity of the secreted reporter enzyme (e.g., SEAP) according to the manufacturer's protocol, typically by measuring absorbance at a specific wavelength.
- **Data Analysis:** Calculate the percent inhibition for each concentration of **DRI-C21041** and determine the IC₅₀ value using a non-linear regression analysis.

Protocol 2: In Vivo Islet Allograft Survival Model (ACE)

- **Animal Models:** Use DBA/2 mice as islet donors and C57BL/6 mice as recipients.
- **Islet Isolation:** Isolate pancreatic islets from donor mice using collagenase digestion followed by density gradient purification.
- **Transplantation:** Transplant a specified number of islet equivalents (e.g., 150 IEQ) into the anterior chamber of the eye of recipient mice.
- **Treatment Administration:**
 - Prepare **DRI-C21041** in a suitable vehicle (e.g., 20% HPβCD).
 - Administer **DRI-C21041** (e.g., 12.5 mg/kg) or vehicle control subcutaneously (s.c.) twice daily (b.i.d.).
 - Begin treatment on day -1 relative to transplantation and continue for a specified duration (e.g., up to day 60).[1]

- Monitoring:
 - Monitor the survival and function of the islet allografts using longitudinal volumetric analysis via imaging.
 - Monitor blood glucose levels in recipient mice to assess graft function.
- Endpoint: The primary endpoint is the median survival time of the islet allografts. Graft rejection is defined by a significant loss of graft volume or return to a diabetic state.

Visualizations

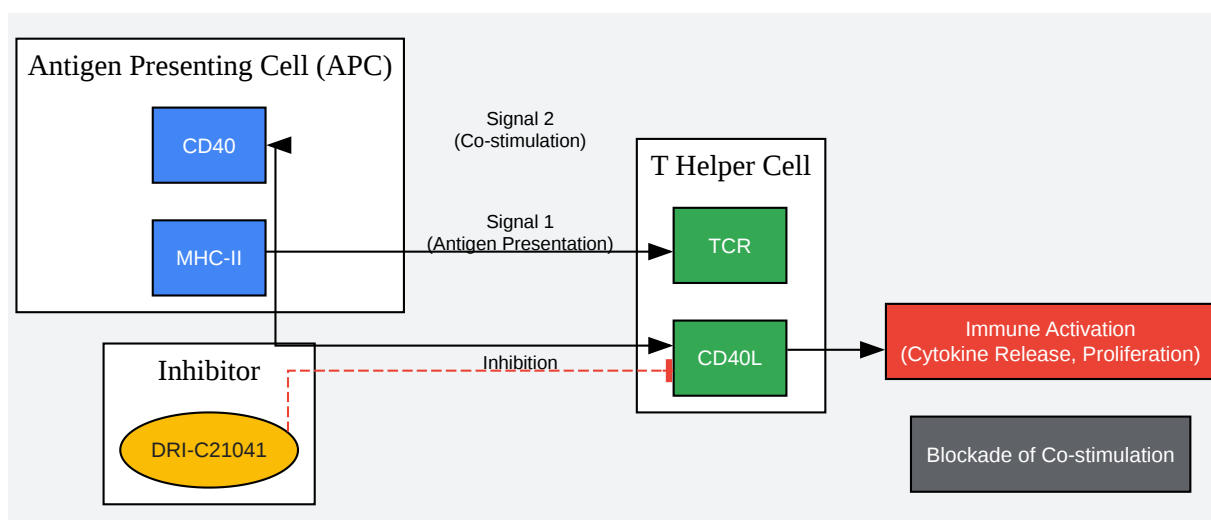

[Click to download full resolution via product page](#)

Caption: Mechanism of action of **DRI-C21041**.

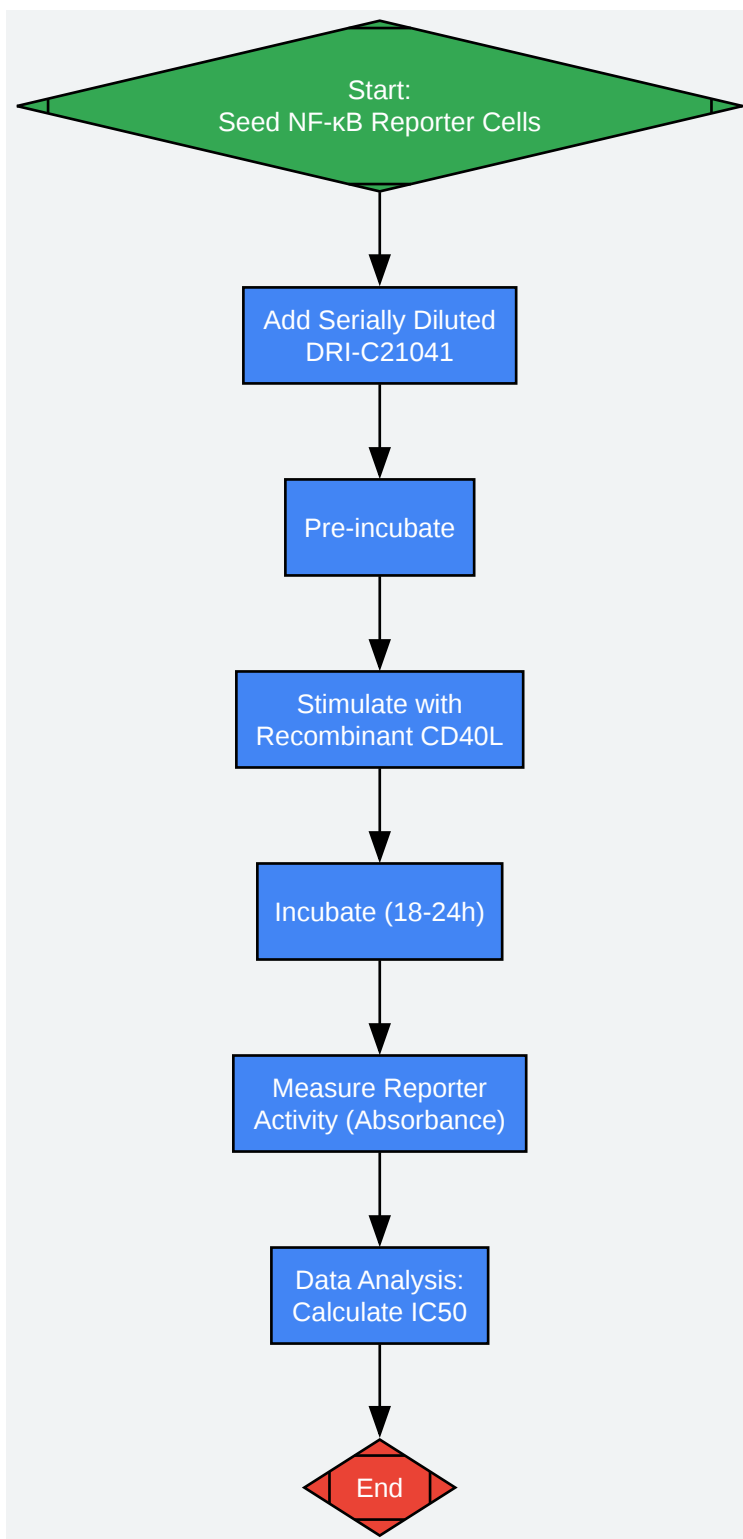

[Click to download full resolution via product page](#)

Caption: In Vitro NF-κB reporter assay workflow.

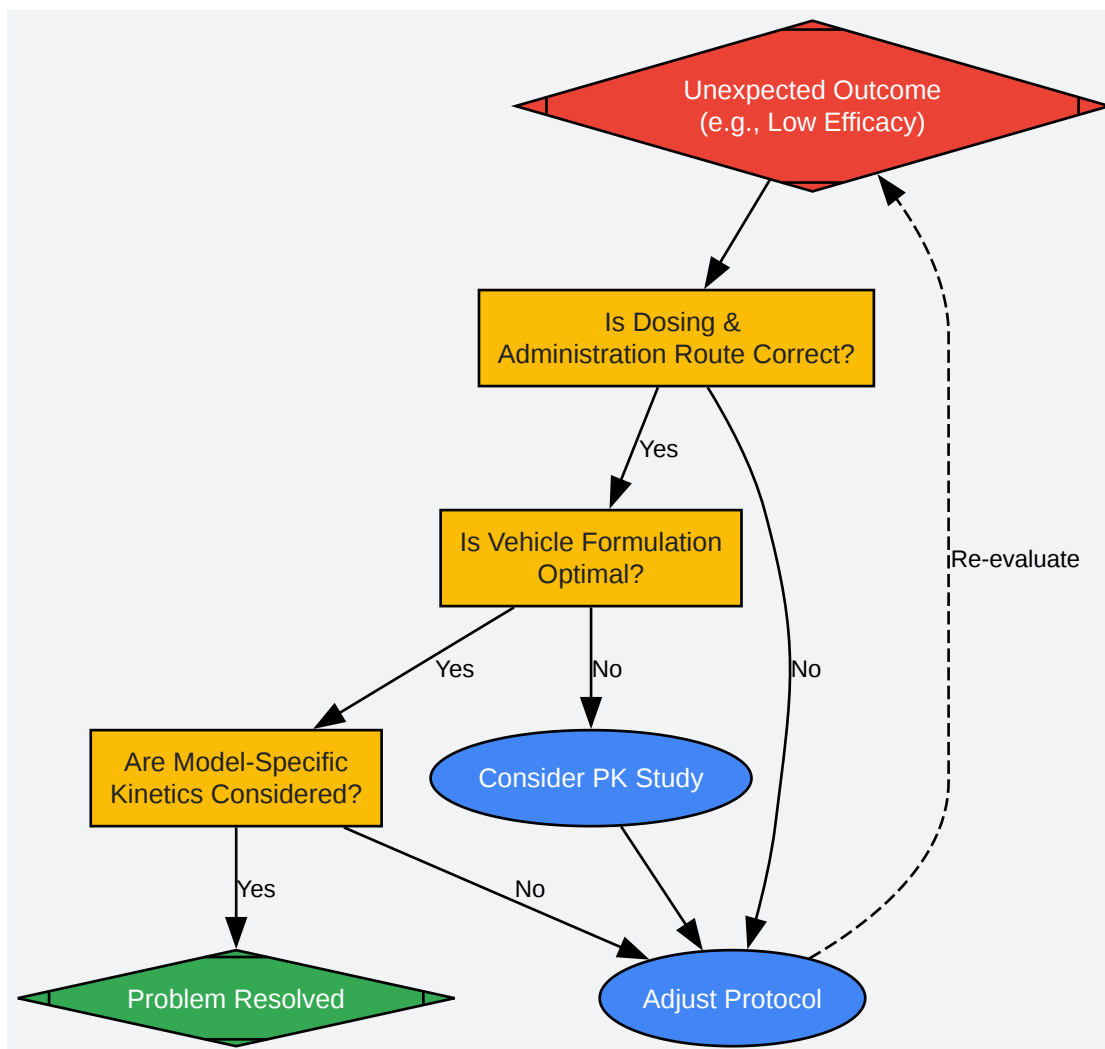

[Click to download full resolution via product page](#)

Caption: Troubleshooting logic for in vivo experiments.

Need Custom Synthesis?

BenchChem offers custom synthesis for rare earth carbides and specific isotopic labeling.

Email: info@benchchem.com or [Request Quote Online](#).

References

- 1. Small-molecule inhibitors of the CD40–CD40L costimulatory interaction are effective in pancreatic islet transplantation and prevention of type 1 diabetes models - PMC [[pmc.ncbi.nlm.nih.gov](https://pubmed.ncbi.nlm.nih.gov/)]

- [2. eledon.com \[eledon.com\]](#)
- [3. medchemexpress.com \[medchemexpress.com\]](#)
- [4. Small-Molecule Inhibitors of the CD40–CD40L Costimulatory Protein-Protein Interaction - PMC \[pmc.ncbi.nlm.nih.gov\]](#)
- [5. Small-molecule inhibitors of the CD40-CD40L costimulatory interaction are effective in pancreatic islet transplantation and prevention of type 1 diabetes models - PubMed \[pubmed.ncbi.nlm.nih.gov\]](#)
- [6. Small-molecule CD40-CD40L interaction inhibitors show promise in islet transplantation mouse models | BioWorld \[bioworld.com\]](#)
- To cite this document: BenchChem. [interpreting unexpected outcomes in DRI-C21041 experiments]. BenchChem, [2026]. [Online PDF]. Available at: [\[https://www.benchchem.com/product/b12384510/docs#interpreting-unexpected-outcomes-in-dri-c21041-experiments\]](https://www.benchchem.com/product/b12384510/docs#interpreting-unexpected-outcomes-in-dri-c21041-experiments)

Disclaimer & Data Validity:

The information provided in this document is for Research Use Only (RUO) and is strictly not intended for diagnostic or therapeutic procedures. While BenchChem strives to provide accurate protocols, we make no warranties, express or implied, regarding the fitness of this product for every specific experimental setup.

Technical Support: The protocols provided are for reference purposes. Unsure if this reagent suits your experiment?

Need Industrial/Bulk Grade? [Request Custom Synthesis Quote](#)

BenchChem

Our mission is to be the trusted global source of essential and advanced chemicals, empowering scientists and researchers to drive progress in science and industry.

Contact

Address: 3281 E Guasti Rd
Ontario, CA 91761, United States
Phone: (601) 213-4426
Email: info@benchchem.com

Contact our Ph.D. Support Team for a compatibility check