

Off-target effects of PTD10 and how to mitigate them

Author: BenchChem Technical Support Team. **Date:** April 2026

Compound of Interest

Compound Name: PTD10
Cat. No.: B12384376

[Get Quote](#)

PTD10 Technical Support Center

Welcome to the technical support center for researchers, scientists, and drug development professionals utilizing **PTD10**. This resource is designed to provide comprehensive troubleshooting guides and frequently asked questions (FAQs) to address specific issues you may encounter during your experiments, with a focus on understanding and mitigating off-target effects.

Frequently Asked Questions (FAQs)

Q1: What is **PTD10** and what are its components?

PTD10 is a highly potent Proteolysis Targeting Chimera (PROTAC) designed to induce the degradation of Bruton's Tyrosine Kinase (BTK).[1] It is a heterobifunctional molecule composed of three key parts: a ligand that binds to the target protein (BTK), a ligand that recruits an E3 ubiquitin ligase, and a linker connecting the two. In the case of **PTD10**, the BTK ligand is based on GDC-0853 (also known as fenebrutinib), a selective and non-covalent BTK inhibitor.[2][3][4][5] The E3 ligase ligand is pomalidomide, which recruits the Cereblon (CRBN) E3 ligase.[1][5]

Q2: What are the known off-target effects of **PTD10**?

The off-target effects of **PTD10** can be attributed to its constituent components: the GDC-0853 "warhead" and the pomalidomide E3 ligase recruiter.

- GDC-0853-related off-targets: GDC-0853 is a highly selective BTK inhibitor.[2][3] Clinical studies in healthy volunteers and patients with B-cell malignancies have shown it to be well-tolerated with no dose-limiting toxicities, suggesting minimal off-target effects from this component.[3][6][7]
- Pomalidomide-related off-targets (Neosubstrate Degradation): The pomalidomide moiety, when bound to CRBN, can induce the degradation of endogenous zinc finger (ZF) proteins, often referred to as "neosubstrates." [8][9][10] This is an inherent activity of pomalidomide and related immunomodulatory drugs (IMiDs).[8][11] Known neosubstrates of pomalidomide include Ikaros (IKZF1), Aiolos (IKZF3), and ZFP91.[8][9] This degradation is independent of BTK.

Q3: How was **PTD10** designed to have improved selectivity?

PTD10 was developed to offer enhanced selectivity compared to earlier BTK PROTACs, many of which were based on the less selective inhibitor ibrutinib.[1][5] Ibrutinib is known to have off-target activity against other kinases. By utilizing the highly selective, non-covalent BTK inhibitor GDC-0853 as the warhead, the potential for off-target kinase degradation by **PTD10** is significantly reduced.[2][5]

Q4: What is the "hook effect" and how does it relate to **PTD10**?

The "hook effect" is a phenomenon observed with PROTACs where increasing the concentration beyond an optimal point results in a decrease in target protein degradation.[8] This occurs because at excessively high concentrations, the PROTAC is more likely to form binary complexes (either **PTD10**-BTK or **PTD10**-CRBN) rather than the productive ternary complex (BTK-**PTD10**-CRBN) required for degradation.[8] These binary complexes are inactive. It is crucial to perform careful dose-response experiments to identify the optimal concentration range for maximal BTK degradation while minimizing the hook effect.[8]

Troubleshooting Guide

Observed Issue	Potential Cause	Recommended Action
Unexpected cellular phenotype not consistent with BTK degradation.	Off-target degradation of pomalidomide neosubstrates (e.g., IKZF1, IKZF3).	<ol style="list-style-type: none">1. Confirm neosubstrate degradation: Use Western blotting to check the levels of known pomalidomide neosubstrates (IKZF1, IKZF3).2. Use a control compound: Compare the phenotype with that induced by a selective BTK inhibitor (e.g., GDC-0853) alone.3. Consider a modified PROTAC: For future experiments, a PROTAC with a modified pomalidomide at the C5 position of the phthalimide ring could be synthesized to reduce neosubstrate degradation.[10]
Decreased BTK degradation at higher concentrations of PTD10.	"Hook effect" due to the formation of non-productive binary complexes.	<ol style="list-style-type: none">1. Perform a detailed dose-response curve: Test a wide range of PTD10 concentrations to identify the optimal concentration for maximal degradation (DCmax).2. Work within the optimal concentration range: For subsequent experiments, use PTD10 at concentrations at or below the determined DCmax.

<p>High off-target protein degradation observed in global proteomics.</p>	<p>1. Promiscuous binding of the GDC-0853 warhead (less likely due to its high selectivity). 2. Off-target activity of the pomalidomide E3 ligase ligand.</p>	<p>1. Validate proteomics hits: Confirm the degradation of high-interest off-targets by an orthogonal method like Western blotting. 2. Assess warhead selectivity: While GDC-0853 is selective, in a novel cell line, it is good practice to confirm the absence of off-target kinase inhibition. 3. Focus on pomalidomide-related off-targets: Cross-reference your list of degraded proteins with known pomalidomide neosubstrates.</p>
---	---	---

<p>No or weak BTK degradation.</p>	<p>1. Poor cell permeability of PTD10. 2. Inefficient ternary complex formation. 3. Low expression of CRBN in the cell line being used.</p>	<p>1. Verify CRBN expression: Confirm the expression of CRBN in your cell line using Western blot or qPCR. 2. Optimize treatment conditions: Vary incubation time and PTD10 concentration. 3. Assess ternary complex formation: If available, use biophysical assays like NanoBRET™ to confirm ternary complex formation in cells.</p>
------------------------------------	---	--

Quantitative Data Summary

Table 1: In Vitro Potency of **PTD10** and Parent Molecules

Compound	Target	Cell Line	Assay	Value	Reference
PTD10	BTK Degradation	Ramos	DC50	0.5 nM	[1]
PTD10	BTK Degradation	JeKo-1	DC50	0.6 nM	MedchemExpress
GDC-0853	BTK Inhibition	-	IC50	0.91 nM	[4]
Pomalidomide	-	-	-	-	-

Table 2: Safety Profile of GDC-0853 (**PTD10** Warhead) in Phase 1 Clinical Trials

Study Population	Maximum Tolerated Dose (MTD)	Common Adverse Events ($\geq 15\%$ of patients)	Reference
Healthy Volunteers	Not reached (up to 600 mg single dose; up to 500 mg daily for 14 days)	Headache, upper respiratory tract infections, cough, oropharyngeal pain, nausea	[3][6]
Relapsed/Refractory B-cell NHL and CLL	Not reached (up to 400 mg once daily)	Fatigue, nausea, diarrhea, thrombocytopenia, headache, abdominal pain, cough, dizziness	[7]

Experimental Protocols

1. Global Proteomics for Off-Target Identification by LC-MS/MS

- Objective: To identify all proteins that are degraded upon treatment with **PTD10** in an unbiased manner.

- Methodology:
 - Cell Culture and Treatment: Culture a relevant cell line to ~70-80% confluency. Treat cells with **PTD10** at its optimal degradation concentration (e.g., 1x DC50) and a higher concentration (e.g., 10x DC50) to assess concentration-dependent off-targets. Include a vehicle control (e.g., DMSO). Incubate for a predetermined time (e.g., 16-24 hours).
 - Cell Lysis: Harvest and wash cells with cold PBS. Lyse the cells in a buffer containing protease and phosphatase inhibitors.
 - Protein Digestion: Quantify protein concentration. Reduce, alkylate, and digest proteins into peptides using an enzyme such as trypsin.
 - LC-MS/MS Analysis: Analyze the resulting peptide mixtures by liquid chromatography-tandem mass spectrometry (LC-MS/MS).
 - Data Analysis: Use appropriate software to identify and quantify peptides and proteins. Compare protein abundance between **PTD10**-treated and vehicle-treated samples to identify significantly downregulated proteins.

2. Western Blot for Validation of Off-Target Degradation

- Objective: To confirm the degradation of specific on-target (BTK) and potential off-target proteins (e.g., IKZF1) identified by proteomics or hypothesized based on the mechanism of pomalidomide.
- Methodology:
 - Cell Treatment and Lysis: Treat cells with a range of **PTD10** concentrations and a vehicle control as described above. Lyse the cells and quantify protein concentration.
 - SDS-PAGE: Separate protein lysates by sodium dodecyl sulfate-polyacrylamide gel electrophoresis (SDS-PAGE).
 - Protein Transfer: Transfer the separated proteins to a nitrocellulose or PVDF membrane.
 - Immunoblotting:

- Block the membrane with a suitable blocking buffer (e.g., 5% non-fat milk or BSA in TBST).
- Incubate the membrane with a validated primary antibody against the protein of interest (e.g., anti-BTK, anti-IKZF1) overnight at 4°C.
- Wash the membrane and incubate with a horseradish peroxidase (HRP)-conjugated secondary antibody.
- Detect the signal using an enhanced chemiluminescence (ECL) substrate.
- Re-probe the membrane with an antibody against a loading control (e.g., GAPDH, β -actin) to ensure equal protein loading.
- Densitometry: Quantify the band intensities to determine the extent of protein degradation.

Visualizations

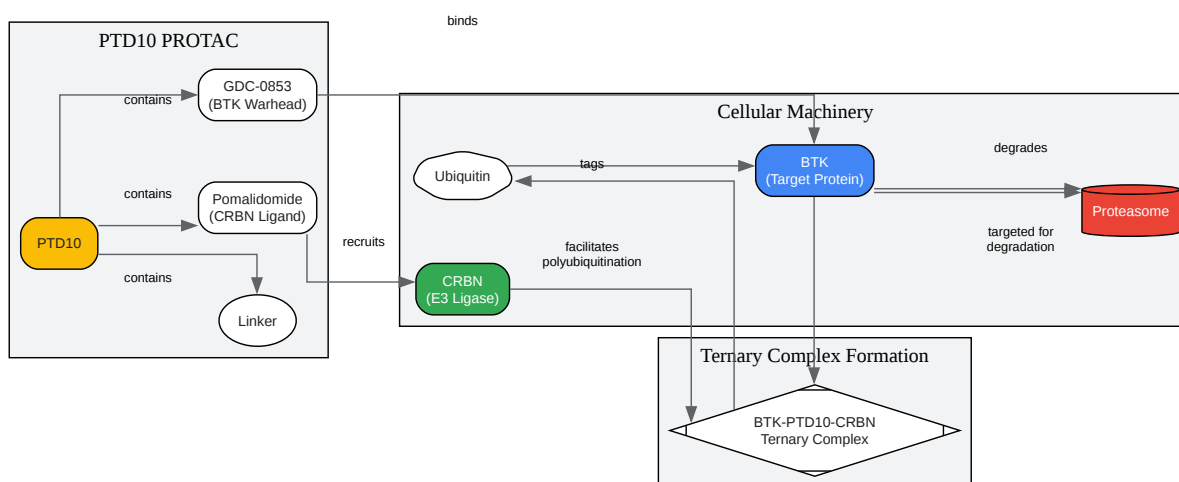

[Click to download full resolution via product page](#)

Caption: Mechanism of action of **PTD10** leading to BTK degradation.

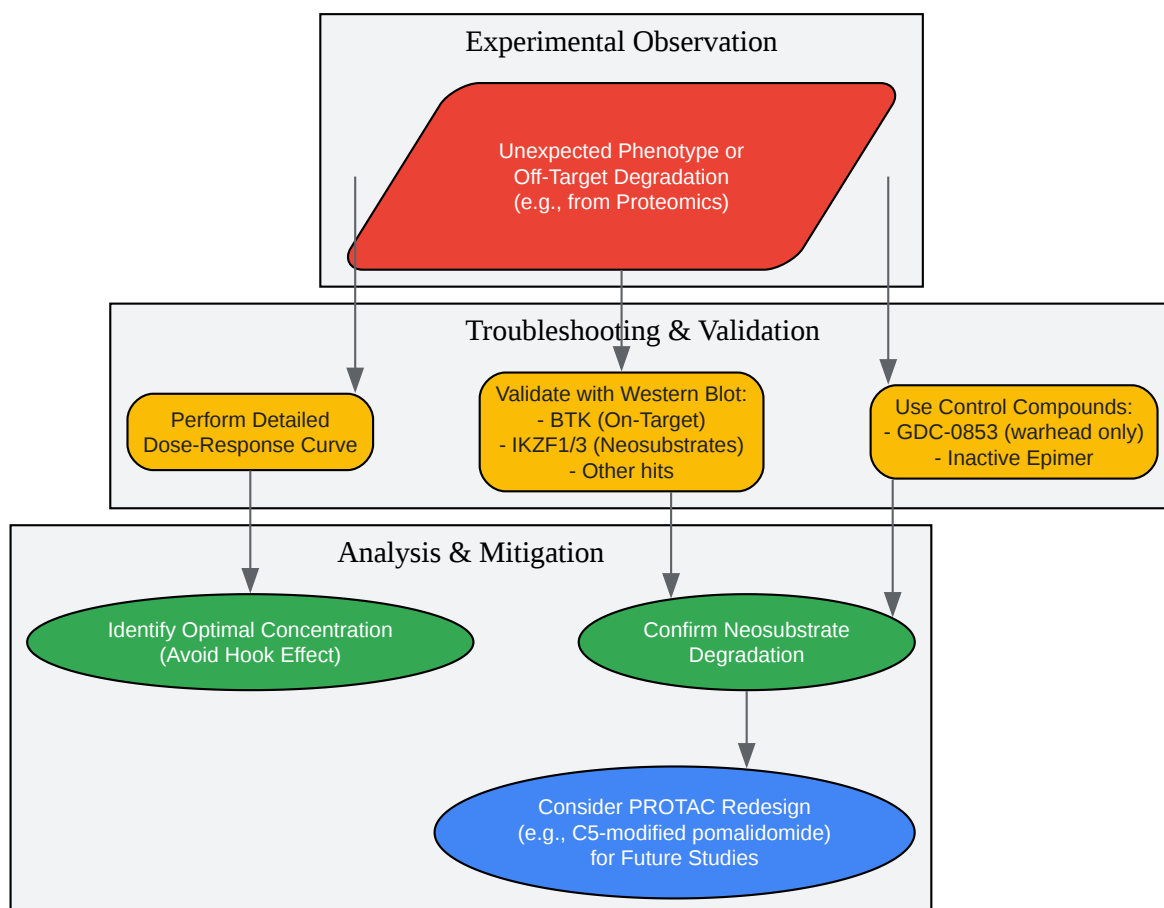

[Click to download full resolution via product page](#)

Need Custom Synthesis?

BenchChem offers custom synthesis for rare earth carbides and specific isotopic labeling.

Email: info@benchchem.com or [Request Quote Online](#).

References

- 1. Discovery of Novel Bruton's Tyrosine Kinase PROTACs with Enhanced Selectivity and Cellular Efficacy - PubMed [pubmed.ncbi.nlm.nih.gov]
- 2. pubs.acs.org [pubs.acs.org]
- 3. Safety, Pharmacokinetics, and Pharmacodynamics in Healthy Volunteers Treated With GDC-0853, a Selective Reversible Bruton's Tyrosine Kinase Inhibitor - PubMed [pubmed.ncbi.nlm.nih.gov]
- 4. researchgate.net [researchgate.net]
- 5. pubs.acs.org [pubs.acs.org]
- 6. researchgate.net [researchgate.net]
- 7. First-in-human phase 1 study of the BTK inhibitor GDC-0853 in relapsed or refractory B-cell NHL and CLL - PMC [pmc.ncbi.nlm.nih.gov]
- 8. benchchem.com [benchchem.com]
- 9. researchgate.net [researchgate.net]
- 10. Proteolysis-targeting chimeras with reduced off-targets - PMC [pmc.ncbi.nlm.nih.gov]
- 11. researchgate.net [researchgate.net]
- To cite this document: BenchChem. [Off-target effects of PTD10 and how to mitigate them]. BenchChem, [2026]. [Online PDF]. Available at: [<https://www.benchchem.com/product/b12384376/docs#off-target-effects-of-ptd10-and-how-to-mitigate-them>]

Disclaimer & Data Validity:

The information provided in this document is for Research Use Only (RUO) and is strictly not intended for diagnostic or therapeutic procedures. While BenchChem strives to provide accurate protocols, we make no warranties, express or implied, regarding the fitness of this product for every specific experimental setup.

Technical Support: The protocols provided are for reference purposes. Unsure if this reagent suits your experiment?

Need Industrial/Bulk Grade? [Request Custom Synthesis Quote](#)

BenchChem

Our mission is to be the trusted global source of essential and advanced chemicals, empowering scientists and researchers to drive progress in science and industry.

Contact

Address: 3281 E Guasti Rd

Ontario, CA 91761, United States

Phone: (601) 213-4426

Email: info@benchchem.com

[Contact our Ph.D. Support Team for a compatibility check](#)