

Navigating Resistance: A Comparative Guide to Synergistic Combinations with EGFR Inhibitors

Author: BenchChem Technical Support Team. **Date:** April 2026

Compound of Interest

Compound Name: *Egfr-IN-98*

Cat. No.: *B12384299*

[Get Quote](#)

A detailed analysis of the enhanced anti-cancer effects achieved by combining Epidermal Growth Factor Receptor (EGFR) inhibitors with other therapeutic agents. This guide provides researchers, scientists, and drug development professionals with a comparative overview of preclinical and clinical data, detailed experimental methodologies, and visual representations of the underlying biological pathways.

Introduction

Targeting the Epidermal Growth Factor Receptor (EGFR) has been a cornerstone of precision oncology for various cancers, particularly non-small cell lung cancer (NSCLC). However, the efficacy of EGFR inhibitors as monotherapy is often limited by the development of acquired resistance. To overcome this challenge, researchers have explored combining EGFR inhibitors with other anti-cancer agents to achieve synergistic effects, leading to more durable responses and improved patient outcomes.

This guide provides a comparative analysis of the synergistic effects of three generations of EGFR inhibitors—Erlotinib (1st generation), Afatinib (2nd generation), and Osimertinib (3rd generation)—when combined with other cancer therapeutics. While the initial query for "**Egfr-IN-98**" did not yield a specific, publicly documented agent, this guide leverages the extensive

data available for these well-characterized inhibitors to provide a comprehensive overview of synergistic strategies in EGFR-targeted therapy.

Comparative Analysis of Synergistic Combinations

The following tables summarize key preclinical and clinical data demonstrating the synergistic or additive effects of combining EGFR inhibitors with chemotherapy, MET inhibitors, and other targeted agents.

Table 1: Synergistic Effects of Erlotinib in Combination Therapies

| Combination Agent | Cancer Type/Cell Line | Key Findings | Quantitative Data | Reference(s) |
|----------------------------|--------------------------------------|--|--|--------------|
| Cisplatin | EGFR-mutated NSCLC (PC9, HCC827) | Synergistic cell death in vitro and greater tumor growth inhibition in vivo. Minimal efficacy in wild-type EGFR NSCLC. | Combination Index (CI): PC9 = 0.45, HCC827 = 0.98. Cell survival with combination in HCC827 was 71.1% vs. 88.1% (Erlotinib) and 91.2% (Cisplatin). | [1][2] |
| SGX523 (MET Inhibitor) | NCI-H596 Lung Cancer | Synergistic inhibition of cell proliferation in vitro and tumor xenograft growth in vivo, particularly in the presence of HGF. | Data suggests greater growth suppression with the combination compared to monotherapy. | [3][4] |
| Crizotinib (MET Inhibitor) | Squamous NSCLC (LUDLU) | Strong synergistic inhibition of cell growth. | Combination Index (CI): 0.39 ± 0.07 . | [5] |
| Chemotherapy | Advanced NSCLC (Acquired Resistance) | Addition of erlotinib to chemotherapy improved response rate (RR). | Objective Response Rate (ORR): 41% with combination vs. 18% with chemotherapy alone. | [6] |

Table 2: Synergistic Effects of Afatinib in Combination Therapies

| Combination Agent | Cancer Type/Cell Line | Key Findings | Quantitative Data | Reference(s) |
|-------------------|--|---|--|--------------|
| Cetuximab | NSCLC with EGFR exon 20 insertion mutations | Additive effect in vitro and significant tumor growth inhibition in vivo. | Mild but significant ($P < 0.05$) additive effect in vitro. | [7] |
| Cetuximab | Head and Neck Squamous Cell Carcinoma (HNSCC) | Additive to antagonistic interactions observed. | Combination Index (CI) ranged from 1.01 \pm 0.06 to 1.96 \pm 0.40. | [8] |
| Cetuximab | NSCLC with acquired resistance to erlotinib/ gefitinib | Encouraging clinical activity in patients with T790M-positive and -negative tumors. | Objective Response Rate (ORR): 29% overall (32% in T790M-positive, 25% in T790M-negative). | [9] |
| Docetaxel | Ovarian Carcinoma (SKOV-3) | Synergistic effect on tumor cells and greater tumor shrinkage in xenograft models. | Preclinical data indicates improved inhibitory activity. | [9] |
| Dasatinib | Gefitinib-resistant NSCLC | Significant synergistic growth inhibition. | Combination Index (CI) < 0.9 . | [10] |

Table 3: Synergistic Effects of Osimertinib in Combination Therapies

| Combination Agent | Cancer Type/Patient Population | Key Findings | Quantitative Data | Reference(s) |
|--------------------------------------|---|---|--|--------------|
| Chemotherapy (Pemetrexed + Platinum) | Advanced EGFR-mutated NSCLC (FLAURA2 trial) | Significantly improved progression-free survival (PFS) and overall survival (OS). | PFS: 25.5 months (combo) vs. 16.7 months (mono). OS: 44.3 months (combo) vs. 37.8 months (mono) (HR=0.80). | [11][12] |
| Savolitinib (MET Inhibitor) | EGFR-mutant, MET-aberrant NSCLC (FLOWERS trial) | Substantially increased objective response rate. | Objective Response Rate (ORR): 90.5% (combo) vs. 60.9% (mono). | [13] |
| Savolitinib (MET Inhibitor) | MET-amplified, EGFR-mutated NSCLC with acquired resistance (TATTON trial) | Encouraging antitumor activity with an acceptable safety profile. | Preliminary response rate of 25% in one cohort. | [14] |
| Chemotherapy | Advanced EGFR-mutated NSCLC with CNS metastases | Improved CNS disease control. | Median CNS PFS: 24.9 months (combo) vs. 13.8 months (mono). | [15] |

Experimental Methodologies

Detailed protocols are crucial for the reproducibility of experimental findings. Below are summaries of methodologies commonly employed in the cited studies.

Cell Viability Assays (MTT/MTS)

These colorimetric assays are used to assess cell metabolic activity as an indicator of cell viability, proliferation, and cytotoxicity in response to drug treatment.

- Cell Plating: Cells are seeded in 96-well plates at a specific density (e.g., 2×10^3 cells/well) and allowed to adhere for 24 hours.[16]
- Drug Treatment: Cells are treated with increasing concentrations of single agents or combinations of drugs. A solvent control (e.g., DMSO) is included.
- Incubation: Plates are incubated for a defined period (e.g., 72 hours).[16]
- Reagent Addition:
 - MTT Assay: MTT solution (e.g., final concentration of 0.45 mg/ml) is added to each well, and plates are incubated for 1-4 hours at 37°C. A solubilization solution is then added to dissolve the formazan crystals.[17][18]
 - MTS Assay: MTS solution containing an electron coupling reagent (e.g., PES) is added to each well, and plates are incubated for 1-4 hours at 37°C.[17][19]
- Data Acquisition: The absorbance is measured using a microplate spectrophotometer at a specific wavelength (e.g., 590 nm for MTT).[18]
- Data Analysis: IC50 values (the concentration of a drug that inhibits 50% of cell growth) are determined using non-linear regression analysis. The synergistic, additive, or antagonistic effects of drug combinations are often quantified by calculating a Combination Index (CI) based on the Chou-Talalay method, where $CI < 1$ indicates synergy, $CI = 1$ indicates an additive effect, and $CI > 1$ indicates antagonism.[5]

Western Blotting

This technique is used to detect specific proteins in a sample and to assess the activation status of signaling pathways by analyzing protein phosphorylation.

- Cell Lysis: Cells are treated with drugs as required, then washed and lysed in a buffer containing protease and phosphatase inhibitors to extract total protein.

- **Protein Quantification:** The protein concentration of the lysates is determined using a standard method (e.g., BCA assay).
- **SDS-PAGE:** Equal amounts of protein are separated by size using sodium dodecyl sulfate-polyacrylamide gel electrophoresis.
- **Protein Transfer:** The separated proteins are transferred from the gel to a membrane (e.g., PVDF or nitrocellulose).
- **Blocking:** The membrane is incubated in a blocking buffer (e.g., 5% non-fat milk or BSA in TBST) to prevent non-specific antibody binding.
- **Primary Antibody Incubation:** The membrane is incubated with a primary antibody specific to the target protein (e.g., anti-pEGFR, anti-EGFR, anti-Actin) overnight at 4°C.[20]
- **Secondary Antibody Incubation:** After washing, the membrane is incubated with a horseradish peroxidase (HRP)-conjugated secondary antibody that recognizes the primary antibody.[20]
- **Detection:** The protein bands are visualized using an enhanced chemiluminescence (ECL) detection system.
- **Analysis:** The intensity of the bands is quantified using densitometry software. Total protein levels and loading controls (e.g., β -actin) are used to normalize the data.[21]

In Vivo Tumor Xenograft Models

Animal models are used to evaluate the anti-tumor efficacy of drug combinations in a living organism.

- **Cell Implantation:** Human cancer cells are injected subcutaneously into immunocompromised mice (e.g., nude or SCID mice).[3]
- **Tumor Growth:** Tumors are allowed to grow to a palpable size (e.g., 100-200 mm³).
- **Treatment:** Mice are randomized into treatment groups (vehicle control, single agents, combination therapy). Drugs are administered according to a specific dose and schedule (e.g., daily oral gavage).[3]

- **Tumor Measurement:** Tumor volume is measured regularly (e.g., twice weekly) using calipers.
- **Endpoint:** The experiment is terminated when tumors in the control group reach a predetermined size or at a specified time point. Tumors are then excised for further analysis (e.g., Western blotting, immunohistochemistry).
- **Data Analysis:** Tumor growth inhibition is calculated and statistical analysis is performed to determine the significance of the observed effects.

Signaling Pathways and Experimental Workflows

The following diagrams, generated using Graphviz, illustrate key signaling pathways and experimental workflows relevant to the synergistic effects of EGFR inhibitors.

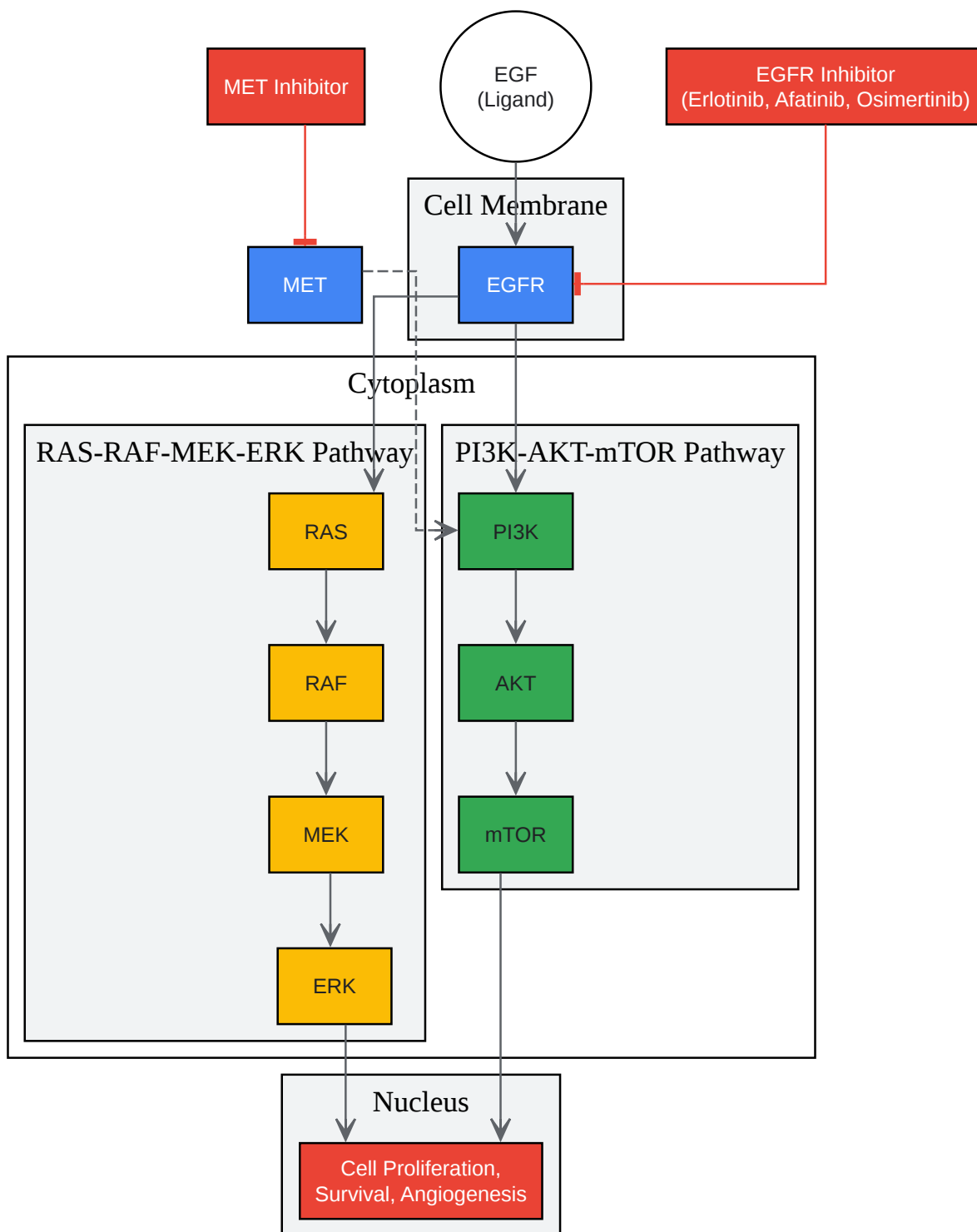

[Click to download full resolution via product page](#)

Caption: EGFR Signaling and Bypass Activation. This diagram illustrates the primary EGFR signaling pathways (RAS-RAF-MEK-ERK and PI3K-AKT-mTOR) and the MET bypass track.

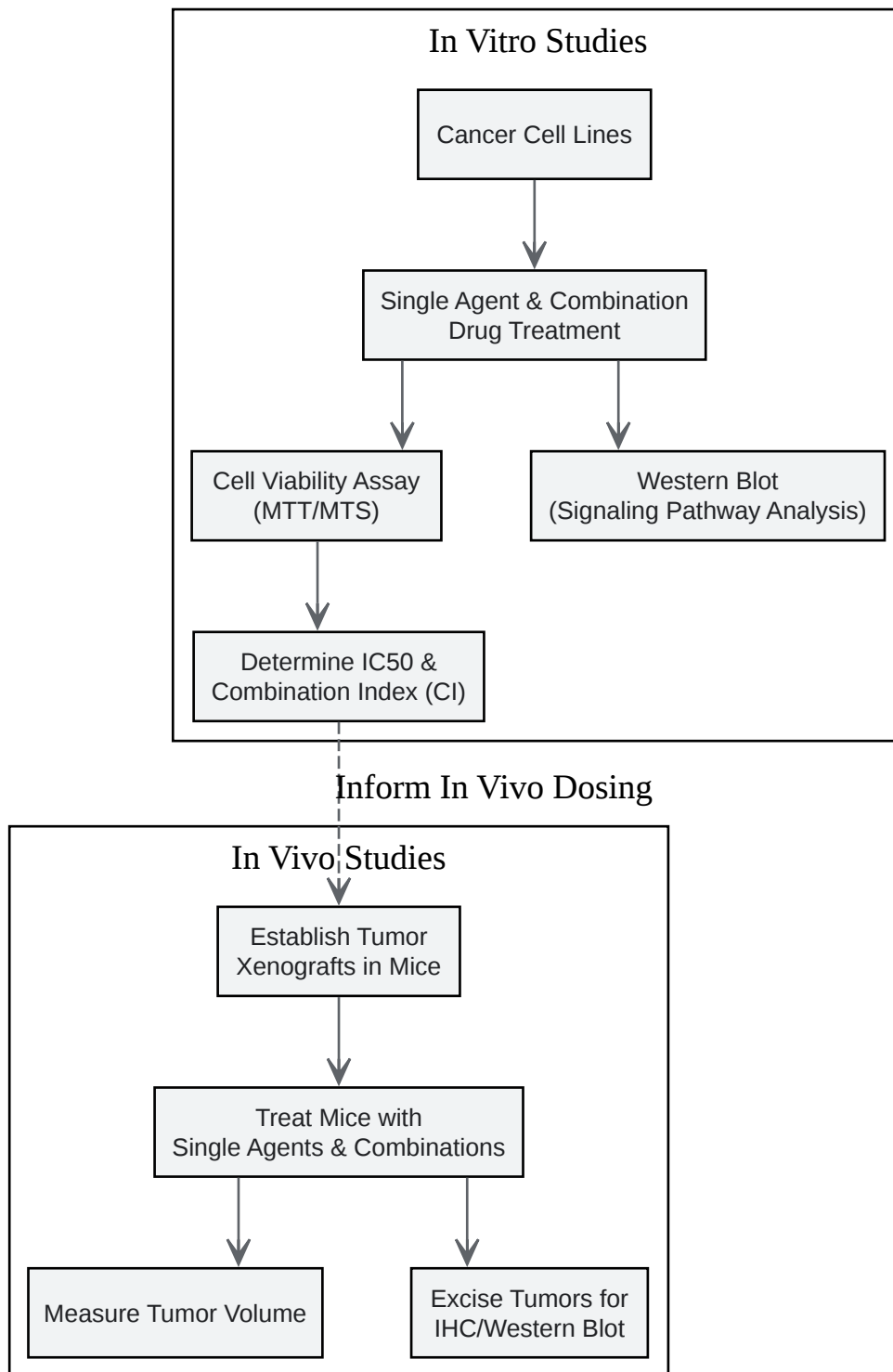

[Click to download full resolution via product page](#)

Caption: Workflow for Synergy Evaluation. This diagram outlines the typical experimental workflow for evaluating the synergistic effects of drug combinations, from in vitro cell-based assays to in vivo animal models.

Conclusion

The combination of EGFR inhibitors with other anti-cancer agents represents a powerful strategy to enhance therapeutic efficacy and overcome drug resistance. The data presented in this guide, drawn from studies on Erlotinib, Afatinib, and Osimertinib, highlight the significant synergistic potential of such combinations across various cancer types. The detailed methodologies and visual workflows provided herein are intended to support researchers in the design and execution of further studies aimed at optimizing combination therapies for patients with EGFR-driven malignancies. As our understanding of the complex signaling networks in cancer deepens, rational drug combinations will continue to be a critical component of advancing precision oncology.

Need Custom Synthesis?

BenchChem offers custom synthesis for rare earth carbides and specific isotopic labeling.

Email: info@benchchem.com or [Request Quote Online](#).

References

- [1. Erlotinib-Cisplatin Combination Inhibits Growth and Angiogenesis through c-MYC and HIF-1 \$\alpha\$ in EGFR-Mutated Lung Cancer In Vitro and In Vivo - PMC \[pmc.ncbi.nlm.nih.gov\]](#)
- [2. Erlotinib-cisplatin combination inhibits growth and angiogenesis through c-MYC and HIF-1 \$\alpha\$ in EGFR-mutated lung cancer in vitro and in vivo - PubMed \[pubmed.ncbi.nlm.nih.gov\]](#)
- [3. aacrjournals.org \[aacrjournals.org\]](#)
- [4. aacrjournals.org \[aacrjournals.org\]](#)
- [5. asco.org \[asco.org\]](#)
- [6. Chemotherapy With Erlotinib or Chemotherapy Alone in Advanced Non-Small Cell Lung Cancer With Acquired Resistance to EGFR Tyrosine Kinase Inhibitors - PMC \[pmc.ncbi.nlm.nih.gov\]](#)

- [7. Efficacy of afatinib or osimertinib plus cetuximab combination therapy for non-small-cell lung cancer with EGFR exon 20 insertion mutations - PubMed \[pubmed.ncbi.nlm.nih.gov\]](#)
- [8. Simultaneous targeting of EGFR, HER2, and HER4 by afatinib overcomes intrinsic and acquired cetuximab resistance in head and neck squamous cell carcinoma cell lines - PMC \[pmc.ncbi.nlm.nih.gov\]](#)
- [9. tandfonline.com \[tandfonline.com\]](#)
- [10. researchgate.net \[researchgate.net\]](#)
- [11. Osimertinib Combined with Chemotherapy Demonstrates Significant Overall Survival Benefit in Advanced EGFR-Mutated Lung Cancer - Content - TribeMD \[tribemd.com\]](#)
- [12. onclive.com \[onclive.com\]](#)
- [13. medpagetoday.com \[medpagetoday.com\]](#)
- [14. Osimertinib Plus Savolitinib in Advanced NSCLC Driven by MET Resistance - The ASCO Post \[ascopost.com\]](#)
- [15. Osimertinib-chemotherapy synergy in EGFR-mutant NSCLC: advancing central nervous system control amidst toxicity considerations - PMC \[pmc.ncbi.nlm.nih.gov\]](#)
- [16. Cell-viability assay and drug combination analysis \[bio-protocol.org\]](#)
- [17. Cell Viability Assays - Assay Guidance Manual - NCBI Bookshelf \[ncbi.nlm.nih.gov\]](#)
- [18. MTT assay protocol | Abcam \[abcam.com\]](#)
- [19. broadpharm.com \[broadpharm.com\]](#)
- [20. Analyzing expression and phosphorylation of the EGF receptor in HNSCC - PMC \[pmc.ncbi.nlm.nih.gov\]](#)
- [21. researchgate.net \[researchgate.net\]](#)
- [To cite this document: BenchChem. \[Navigating Resistance: A Comparative Guide to Synergistic Combinations with EGFR Inhibitors\]. BenchChem, \[2026\]. \[Online PDF\]. Available at: \[https://www.benchchem.com/product/b12384299/docs#navigating-resistance-a-comparative-guide-to-synergistic-combinations-with-egfr-inhibitors\]](#)

Disclaimer & Data Validity:

The information provided in this document is for Research Use Only (RUO) and is strictly not intended for diagnostic or therapeutic procedures. While BenchChem strives to provide accurate protocols, we make no warranties, express or implied, regarding the fitness of this product for every specific experimental setup.

Technical Support: The protocols provided are for reference purposes. Unsure if this reagent suits your experiment?

Need Industrial/Bulk Grade? [Request Custom Synthesis Quote](#)

BenchChem

Our mission is to be the trusted global source of essential and advanced chemicals, empowering scientists and researchers to drive progress in science and industry.

Contact

Address: 3281 E Guasti Rd
Ontario, CA 91761, United States
Phone: (601) 213-4426
Email: info@benchchem.com

[Contact our Ph.D. Support Team for a compatibility check](#)