

# Cell viability issues with PTD10 treatment

**Author:** BenchChem Technical Support Team. **Date:** April 2026

## Compound of Interest

Compound Name: PTD10  
Cat. No.: B12384376

[Get Quote](#)

## Technical Support Center: PTD10 Treatment

This technical support center provides troubleshooting guidance and frequently asked questions for researchers, scientists, and drug development professionals utilizing **PTD10** in their experiments.

## Troubleshooting Guide

This guide addresses common cell viability issues that may be encountered during **PTD10** treatment.

Observation	Potential Cause	Suggested Solution
<p>Lower than expected cell viability/higher cytotoxicity in sensitive cell lines (e.g., TMD8, Mino).</p>	<p>1. Incorrect PTD10 concentration: PTD10 is highly potent, with nanomolar efficacy.<sup>[1][2][3][4][5][6]</sup> Minor miscalculations can lead to significant cell death. 2. Cell line health: Pre-existing issues such as mycoplasma contamination or poor cell health can increase sensitivity to treatment. 3. Solvent toxicity: High concentrations of the solvent (e.g., DMSO) used to dissolve PTD10 may be toxic to cells.</p>	<p>1. Verify concentration: Double-check all calculations for dilutions. Perform a dose-response curve to determine the optimal concentration for your specific cell line and experimental conditions. 2. Cell line maintenance: Regularly test for mycoplasma. Ensure cells are in the logarithmic growth phase and have high viability before starting the experiment. 3. Solvent control: Include a vehicle-only control group to assess the effect of the solvent on cell viability. Keep the final solvent concentration consistent across all treatment groups and as low as possible.</p>
<p>High variability in cell viability results between replicates.</p>	<p>1. Inconsistent cell seeding: Uneven cell distribution in multi-well plates. 2. Edge effects: Cells in the outer wells of a plate may behave differently due to temperature and humidity gradients. 3. Inconsistent PTD10 addition: Variation in the volume or timing of PTD10 addition to wells.</p>	<p>1. Proper cell suspension: Ensure a single-cell suspension before seeding and mix thoroughly between plating each replicate. 2. Plate layout: Avoid using the outermost wells of the plate for experimental samples. Fill these wells with sterile PBS or media to maintain humidity. 3. Consistent technique: Use calibrated pipettes and a consistent method for adding the treatment to each well.</p>

---

No significant effect on cell viability in expectedly sensitive cell lines.

1. PTD10 degradation: Improper storage or handling of the PTD10 stock solution. 2. Resistant cell line: The cell line used may not be dependent on the BTK signaling pathway for survival. 3. Sub-optimal incubation time: The duration of PTD10 treatment may be insufficient to induce a measurable effect on cell viability.

1. Proper storage: Store PTD10 stock solutions as recommended by the manufacturer, typically at -20°C or -80°C, and protect from light. Prepare fresh dilutions for each experiment. 2. Cell line characterization: Confirm the expression and functional importance of BTK in your cell line. Consider testing PTD10 on a positive control cell line known to be sensitive (e.g., TMD8). 3. Time-course experiment: Perform a time-course experiment (e.g., 24, 48, 72 hours) to determine the optimal treatment duration.

---

Discrepancy between different viability assays (e.g., MTT vs. Apoptosis Assay).

1. Different cellular processes measured: MTT assays measure metabolic activity, which may not directly correlate with early-stage apoptosis.<sup>[7][8]</sup> Apoptosis assays like Annexin V/PI staining detect specific cell death events. 2. Timing of assays: The chosen time point might be optimal for detecting changes in one assay but not the other.

1. Use complementary assays: It is recommended to use multiple assays to assess cell viability and death. For example, an MTT assay for metabolic activity can be complemented with an Annexin V/PI assay to specifically quantify apoptosis and necrosis. 2. Optimize assay timing: Conduct a time-course experiment and perform both assays at multiple time points to capture the full spectrum of cellular responses to PTD10.

## Frequently Asked Questions (FAQs)

Q1: What is **PTD10** and how does it work?

**PTD10** is a highly potent, selective PROTAC (Proteolysis Targeting Chimera) that targets Bruton's tyrosine kinase (BTK) for degradation.<sup>[1][2][3][4][5][6]</sup> It is a heterobifunctional molecule composed of a ligand that binds to BTK and another ligand that recruits the E3 ubiquitin ligase cereblon.<sup>[1][2]</sup> This proximity induces the ubiquitination and subsequent proteasomal degradation of BTK, leading to the inhibition of the B-cell receptor (BCR) signaling pathway.<sup>[1]</sup>

Q2: In which cell lines is **PTD10** expected to be effective?

**PTD10** is particularly effective in B-cell malignant cell lines that are dependent on the BTK signaling pathway for their proliferation and survival.<sup>[1]</sup> Cell lines such as TMD8 and Mino have shown high sensitivity to **PTD10** treatment.<sup>[1]</sup>

Q3: What is the mechanism of cell death induced by **PTD10**?

**PTD10** induces apoptosis through the activation of the caspase-dependent and mitochondrial (intrinsic) pathways.<sup>[1][2]</sup> This is evidenced by the cleavage of PARP and caspase-3, and the downregulation of anti-apoptotic proteins like Bcl-2 and Mcl-1.<sup>[1]</sup>

Q4: What are the typical IC50 values for **PTD10**?

The half-maximal inhibitory concentration (IC50) for **PTD10** is in the low nanomolar range in sensitive cell lines. For example:

Cell Line	IC50 Value (nM)
TMD8	1.4
Mino	2.2

Data from Li YQ, et al. J Med Chem. 2023.<sup>[1]</sup>

Q5: How should I prepare and store **PTD10**?

**PTD10** is typically supplied as a solid. It should be dissolved in a suitable solvent, such as DMSO, to create a stock solution. It is recommended to store the stock solution in small aliquots at -20°C or -80°C to avoid repeated freeze-thaw cycles. Protect the stock solution and any dilutions from light. For cell-based assays, further dilute the stock solution in the appropriate cell culture medium to the desired final concentration.

## Experimental Protocols

### Cell Viability Assessment using MTT Assay

This protocol is adapted from standard MTT assay procedures.<sup>[7][8]</sup>

Materials:

- **PTD10**
- 96-well cell culture plates
- MTT (3-(4,5-dimethylthiazol-2-yl)-2,5-diphenyltetrazolium bromide) solution (5 mg/mL in PBS)
- Solubilization solution (e.g., DMSO or a solution of 10% SDS in 0.01 M HCl)
- Microplate reader

Procedure:

- **Cell Seeding:** Seed cells in a 96-well plate at a predetermined optimal density and allow them to adhere overnight.
- **PTD10 Treatment:** Prepare serial dilutions of **PTD10** in culture medium. Remove the old medium from the wells and add the **PTD10** dilutions. Include a vehicle-only control.
- **Incubation:** Incubate the plate for the desired treatment duration (e.g., 24, 48, or 72 hours) at 37°C in a humidified incubator with 5% CO<sub>2</sub>.
- **MTT Addition:** Add 10 µL of MTT solution to each well and incubate for 2-4 hours at 37°C, allowing viable cells to metabolize MTT into formazan crystals.

- Solubilization: Carefully remove the medium and add 100  $\mu$ L of the solubilization solution to each well to dissolve the formazan crystals.
- Absorbance Reading: Measure the absorbance at a wavelength of 570 nm using a microplate reader.
- Data Analysis: Calculate cell viability as a percentage of the vehicle-treated control.

## Apoptosis Detection by Annexin V/PI Staining and Flow Cytometry

This protocol is based on standard procedures for Annexin V and Propidium Iodide (PI) staining.

Materials:

- **PTD10**
- 6-well cell culture plates
- Annexin V-FITC/APC kit (containing Annexin V, Propidium Iodide, and Binding Buffer)
- Flow cytometer

Procedure:

- Cell Seeding and Treatment: Seed cells in 6-well plates and treat with the desired concentrations of **PTD10** for the appropriate duration. Include both untreated and vehicle-only controls.
- Cell Harvesting: Collect both adherent and floating cells. For adherent cells, gently trypsinize and combine with the supernatant.
- Washing: Wash the cells twice with cold PBS by centrifuging at 300 x g for 5 minutes.
- Staining: Resuspend the cell pellet in 1X Binding Buffer. Add Annexin V-FITC/APC and PI according to the manufacturer's instructions.

- Incubation: Incubate the cells for 15 minutes at room temperature in the dark.
- Flow Cytometry Analysis: Analyze the stained cells on a flow cytometer within one hour.
- Data Interpretation:
  - Annexin V- / PI-: Live cells
  - Annexin V+ / PI-: Early apoptotic cells
  - Annexin V+ / PI+: Late apoptotic/necrotic cells
  - Annexin V- / PI+: Necrotic cells

## Visualizations

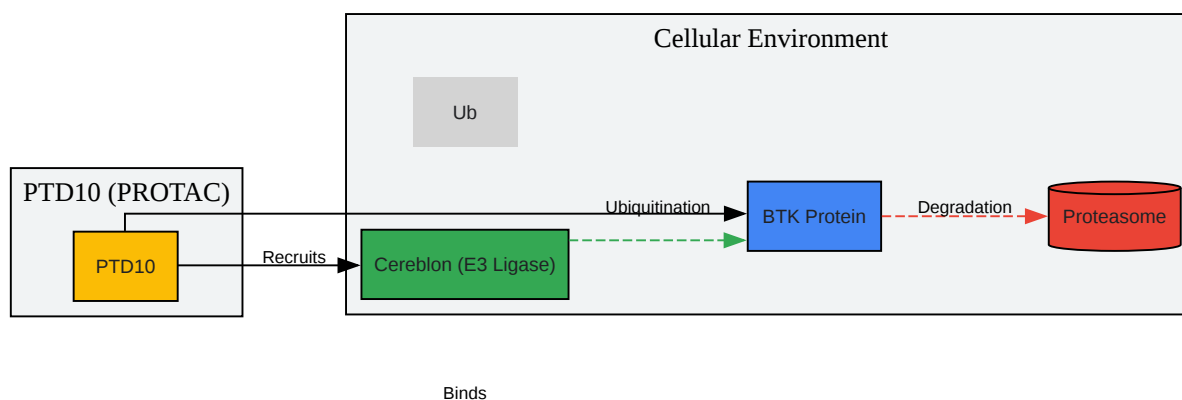

[Click to download full resolution via product page](#)

Caption: Mechanism of **PTD10**-induced BTK degradation.

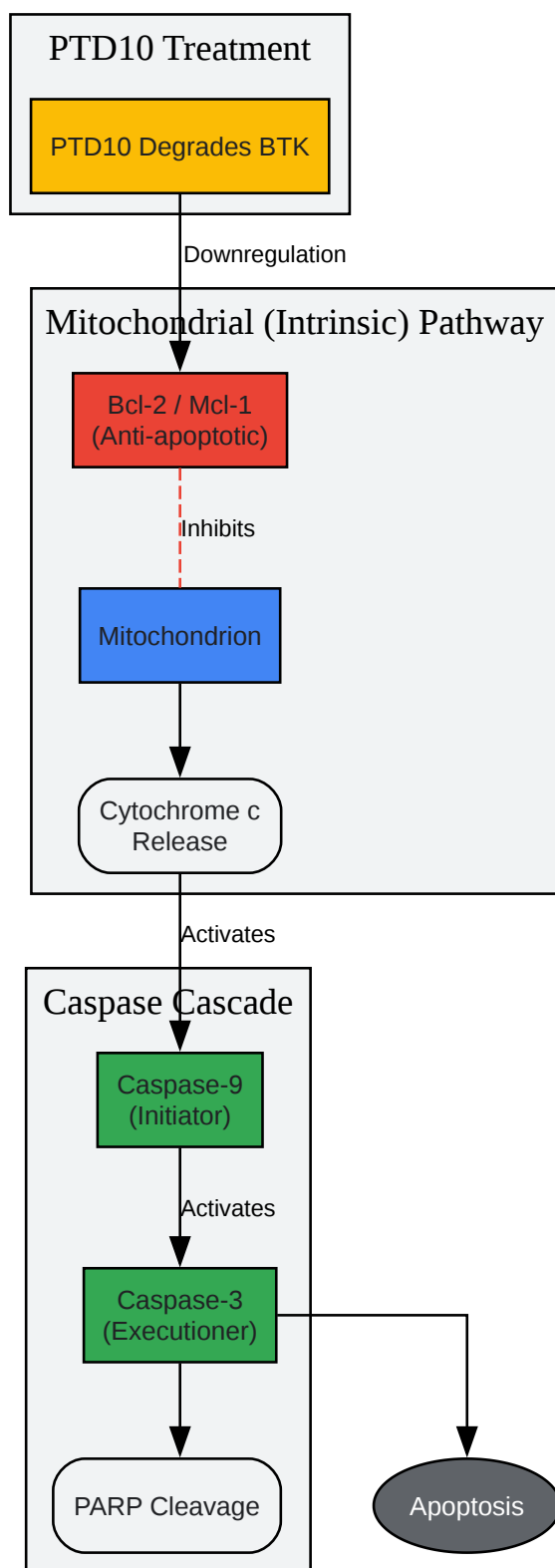

[Click to download full resolution via product page](#)

Caption: **PTD10**-induced apoptotic signaling pathway.

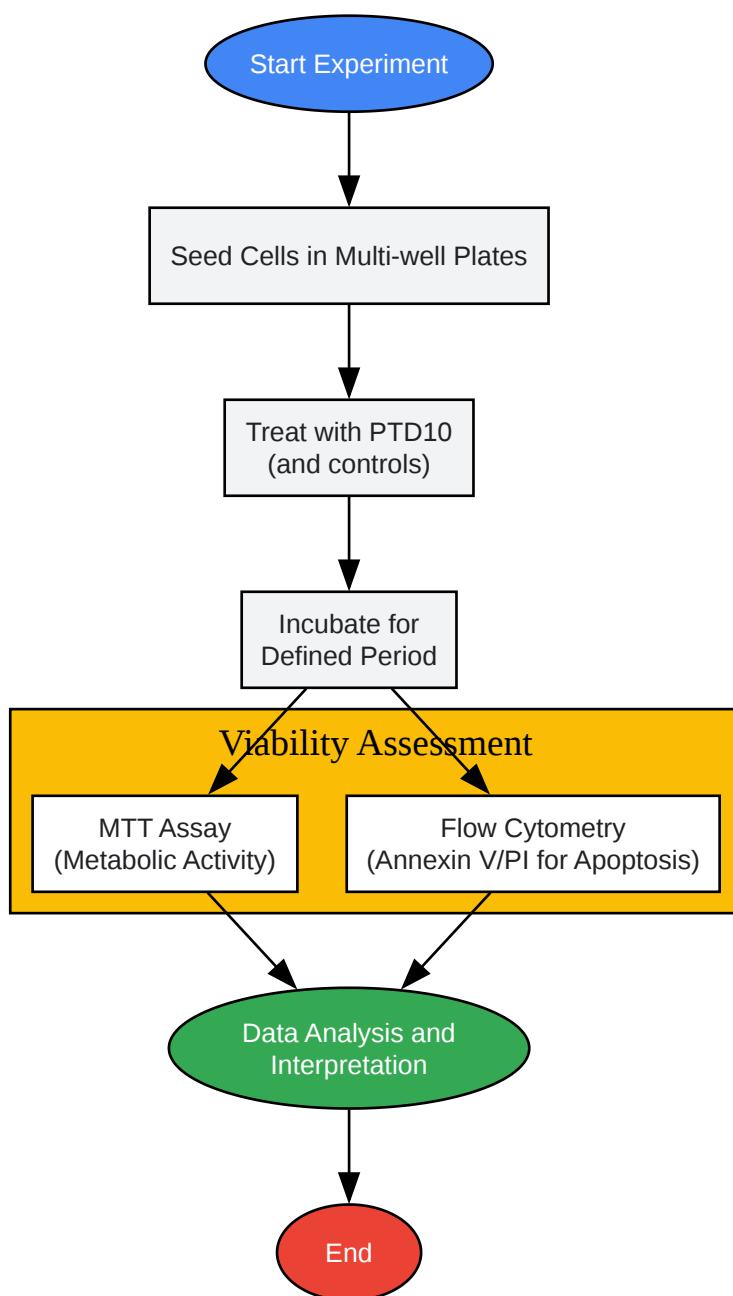

[Click to download full resolution via product page](#)

Caption: General experimental workflow for assessing **PTD10** effects.

#### *Need Custom Synthesis?*

*BenchChem offers custom synthesis for rare earth carbides and specific isotopic labeling.*

*Email: [info@benchchem.com](mailto:info@benchchem.com) or [Request Quote Online](#).*

## References

- 1. Discovery of Novel Bruton's Tyrosine Kinase PROTACs with Enhanced Selectivity and Cellular Efficacy - PMC [[pmc.ncbi.nlm.nih.gov](https://pubmed.ncbi.nlm.nih.gov/pmc/)]
- 2. [medchemexpress.com](https://www.medchemexpress.com) [[medchemexpress.com](https://www.medchemexpress.com)]
- 3. [medkoo.com](https://www.medkoo.com) [[medkoo.com](https://www.medkoo.com)]
- 4. [pubs.acs.org](https://pubs.acs.org) [[pubs.acs.org](https://pubs.acs.org)]
- 5. [researchgate.net](https://www.researchgate.net) [[researchgate.net](https://www.researchgate.net)]
- 6. Discovery of Novel Bruton's Tyrosine Kinase PROTACs with Enhanced Selectivity and Cellular Efficacy - PubMed [[pubmed.ncbi.nlm.nih.gov](https://pubmed.ncbi.nlm.nih.gov/)]
- 7. [m.media-amazon.com](https://www.m.media-amazon.com) [[m.media-amazon.com](https://www.m.media-amazon.com)]
- 8. [manual.nz](https://www.manual.nz) [[manual.nz](https://www.manual.nz)]
- To cite this document: BenchChem. [Cell viability issues with PTD10 treatment]. BenchChem, [2026]. [Online PDF]. Available at: [<https://www.benchchem.com/product/b12384376/docs#cell-viability-issues-with-ptd10-treatment>]

---

### Disclaimer & Data Validity:

The information provided in this document is for Research Use Only (RUO) and is strictly not intended for diagnostic or therapeutic procedures. While BenchChem strives to provide accurate protocols, we make no warranties, express or implied, regarding the fitness of this product for every specific experimental setup.

**Technical Support:** The protocols provided are for reference purposes. Unsure if this reagent suits your experiment?

**Need Industrial/Bulk Grade?** [Request Custom Synthesis Quote](#)

# BenchChem

Our mission is to be the trusted global source of essential and advanced chemicals, empowering scientists and researchers to drive progress in science and industry.

## Contact

Address: 3281 E Guasti Rd

Ontario, CA 91761, United States

Phone: (601) 213-4426

Email: [info@benchchem.com](mailto:info@benchchem.com)

[Contact our Ph.D. Support Team for a compatibility check](#)