

Sdh-IN-5 succinate dehydrogenase inhibition

Author: BenchChem Technical Support Team. **Date:** December 2025

Compound of Interest

Compound Name: Sdh-IN-5

Cat. No.: B12383466

[Get Quote](#)

An In-Depth Technical Guide to Succinate Dehydrogenase (SDH) Inhibition for Researchers and Drug Development Professionals

Abstract

Succinate dehydrogenase (SDH), also known as mitochondrial complex II, is a critical enzyme that functions at the intersection of the tricarboxylic acid (TCA) cycle and the electron transport chain (ETC). Its dual role in cellular metabolism makes it a compelling target for therapeutic intervention in a variety of diseases, including cancer and ischemia-reperfusion injury. This technical guide provides a comprehensive overview of the core principles of SDH inhibition, catering to researchers, scientists, and drug development professionals. It details the mechanisms of action of prominent SDH inhibitors, presents quantitative data for comparative analysis, and offers detailed protocols for key experimental assays. Furthermore, this guide utilizes visualizations to illustrate complex signaling pathways and experimental workflows, providing a thorough resource for the study of SDH inhibition.

Introduction to Succinate Dehydrogenase (SDH)

Succinate dehydrogenase is a heterotetrameric protein complex embedded in the inner mitochondrial membrane. It is unique as it is the only enzyme that participates in both the TCA cycle and the ETC. In the TCA cycle, SDH catalyzes the oxidation of succinate to fumarate. The electrons harvested from this reaction are passed through a series of iron-sulfur clusters within the SDH complex before being transferred to ubiquinone (Coenzyme Q) in the ETC. This process contributes to the generation of the proton gradient that drives ATP synthesis.

Inhibition of SDH disrupts these fundamental cellular processes, leading to a cascade of downstream effects. The accumulation of succinate, a key consequence of SDH inhibition, has been identified as an oncometabolite. It can competitively inhibit α -ketoglutarate-dependent dioxygenases, including prolyl hydroxylases, leading to the stabilization of hypoxia-inducible factor 1-alpha (HIF-1 α) and promoting a pseudohypoxic state that can drive tumor growth and angiogenesis.[1][2][3][4] Furthermore, the disruption of electron flow through the ETC due to SDH inhibition can lead to the generation of reactive oxygen species (ROS), contributing to oxidative stress and cellular damage.[5][6][7]

Mechanisms of SDH Inhibition

SDH inhibitors can be broadly classified based on their binding site and mechanism of action. The two primary classes of inhibitors target either the succinate-binding site on the SDHA subunit or the ubiquinone-binding site within the complex.

- **Competitive Inhibitors (Succinate Binding Site):** These inhibitors, such as malonate, are structurally similar to the endogenous substrate succinate. They bind to the active site of SDH but cannot be oxidized, thereby competitively inhibiting the enzyme.[8]
- **Ubiquinone-Binding Site Inhibitors:** This class of inhibitors, which includes the potent inhibitor atpenin A5, binds to the ubiquinone reduction site of the SDH complex. This binding event blocks the transfer of electrons to coenzyme Q, effectively halting the flow of electrons from succinate into the ETC.[9]
- **Irreversible Inhibitors:** Some inhibitors, like 3-nitropropionic acid (3-NPA), act as suicide inhibitors. They are processed by SDH, leading to the formation of a reactive intermediate that covalently binds to and irreversibly inactivates the enzyme.[10]

Quantitative Data for SDH Inhibitors

The potency of SDH inhibitors is typically quantified by their half-maximal inhibitory concentration (IC₅₀) or their inhibitor constant (K_i). These values can vary depending on the specific inhibitor, the source of the enzyme (e.g., mammalian, fungal), and the assay conditions. The following table summarizes the inhibitory activities of several well-characterized SDH inhibitors.

Inhibitor	Type of Inhibition	Target Site	IC50	Ki	Organism /Source	Reference(s)
Atpenin A5	Non-competitive /Ubiquinone antagonist	Ubiquinone-binding site	3.7 - 10 nM	-	Mammalian mitochondria	[9][11][12][13]
3-Nitropropionic Acid (3-NPA)	Irreversible (suicide inhibitor)	Succinate-binding site	-	-	Rat brain	[10][14]
Malonate	Competitive	Succinate-binding site	~40 μ M	-	Mammalian mitochondria	[8][15]
Carboxin	Ubiquinone antagonist	Ubiquinone-binding site	1.1 μ M	-	Bovine heart mitochondria	[12]
Thenoyltrifluoroacetone (TTFA)	Ubiquinone antagonist	Ubiquinone-binding site	5.8 μ M	-	Bovine heart mitochondria	[12]

Signaling Pathways and Logical Relationships

The inhibition of SDH triggers a series of downstream signaling events. The following diagrams, generated using the DOT language, illustrate these key pathways and experimental workflows.

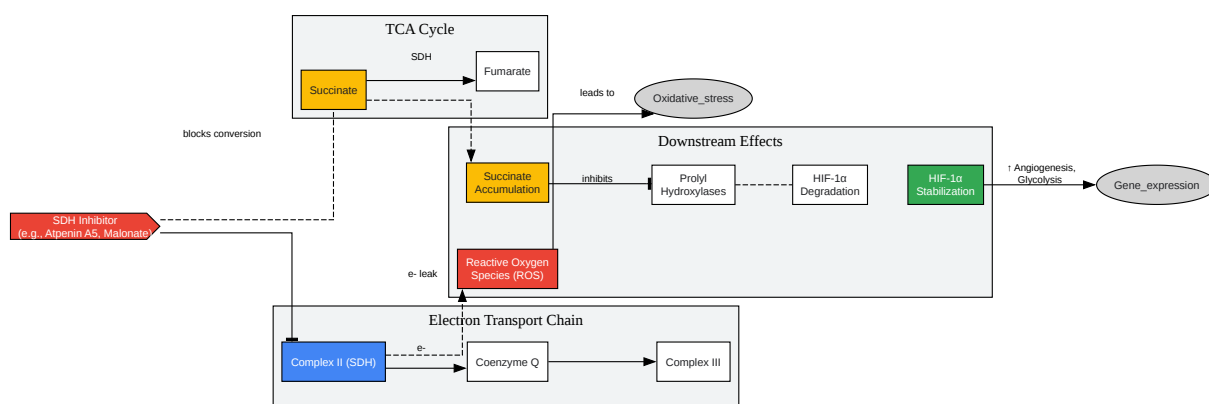

[Click to download full resolution via product page](#)

Mechanism of SDH inhibition and its downstream consequences.

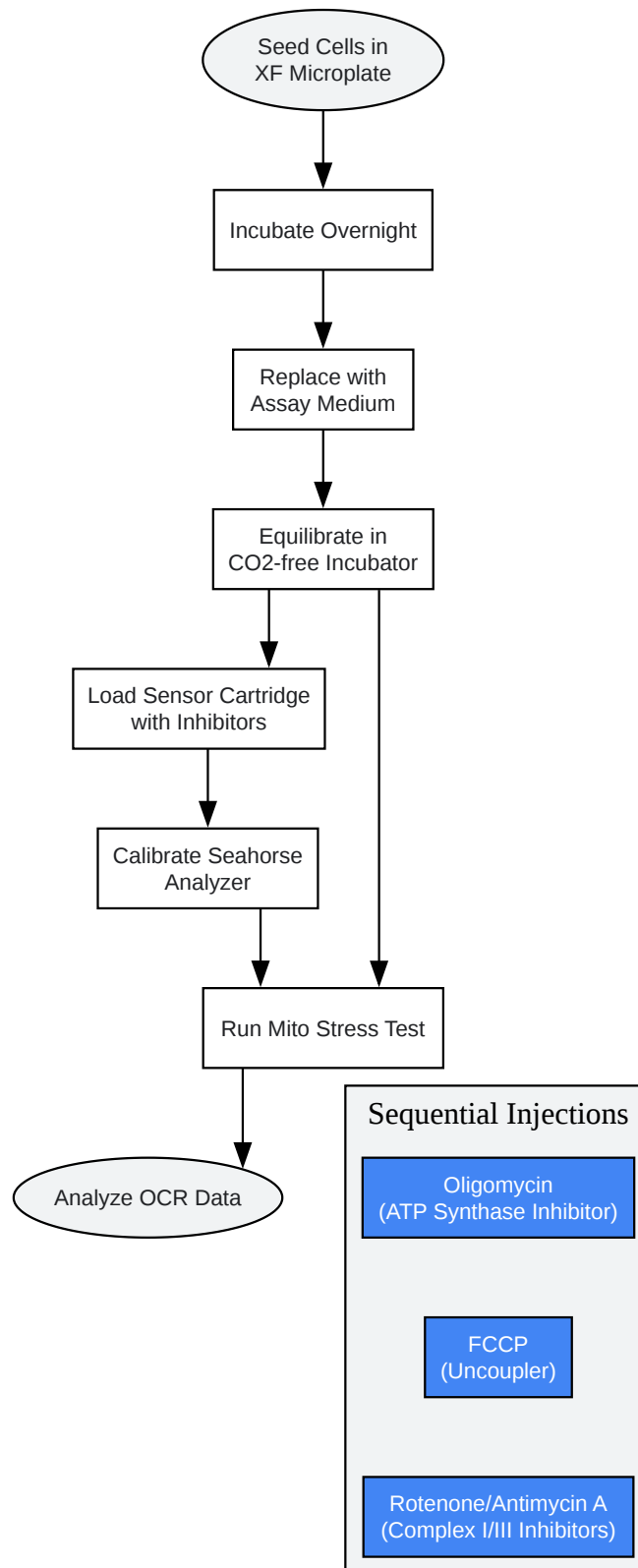

[Click to download full resolution via product page](#)

Experimental workflow for the Seahorse XF Cell Mito Stress Test.

Experimental Protocols

This section provides detailed methodologies for key experiments used to characterize SDH inhibition.

Succinate Dehydrogenase (SDH) Activity Assay (DCPIP-Based)

This colorimetric assay measures SDH activity by monitoring the reduction of 2,6-dichlorophenolindophenol (DCPIP), an artificial electron acceptor.

Materials:

- SDH Assay Buffer (e.g., 50 mM potassium phosphate, pH 7.4)
- Succinate solution (e.g., 1 M stock)
- DCPIP solution (e.g., 2 mM stock in water)
- Phenazine methosulfate (PMS) solution (e.g., 20 mM stock in water, prepare fresh and protect from light)
- Isolated mitochondria or cell/tissue lysates
- 96-well microplate
- Microplate reader capable of measuring absorbance at 600 nm

Procedure:

- Prepare a reaction mixture containing SDH Assay Buffer, succinate (final concentration e.g., 20 mM), and DCPIP (final concentration e.g., 50 μ M).
- Add isolated mitochondria or cell/tissue lysate to the wells of a 96-well plate.
- To initiate the reaction, add PMS (final concentration e.g., 1 mM) to each well.

- Immediately measure the absorbance at 600 nm at 37°C in kinetic mode for a set period (e.g., 10-30 minutes), taking readings every 30-60 seconds.
- The rate of decrease in absorbance at 600 nm is proportional to the SDH activity.
- For inhibitor studies, pre-incubate the mitochondria/lysate with the inhibitor for a defined period before adding the reaction mixture.

Cellular Respiration Assay (Seahorse XF Cell Mito Stress Test)

This assay measures the oxygen consumption rate (OCR) of live cells in real-time, providing insights into mitochondrial function.

Materials:

- Seahorse XF Analyzer (e.g., XFe96)
- Seahorse XF Cell Culture Microplates
- Seahorse XF Calibrant
- XF Base Medium supplemented with glucose, pyruvate, and glutamine
- Oligomycin, FCCP, and Rotenone/Antimycin A (typically from a Seahorse XF Cell Mito Stress Test Kit)

Procedure:

- Seed cells in a Seahorse XF Cell Culture Microplate and allow them to adhere overnight.[\[16\]](#)
- The following day, hydrate the sensor cartridge with Seahorse XF Calibrant in a non-CO₂ incubator at 37°C.[\[17\]](#)
- Replace the cell culture medium with pre-warmed XF Assay Medium and incubate the cell plate in a non-CO₂ incubator at 37°C for 1 hour.[\[16\]](#)

- Load the sensor cartridge with oligomycin, FCCP, and rotenone/antimycin A into the appropriate ports.[18]
- Calibrate the Seahorse XF Analyzer with the sensor cartridge.
- Replace the calibrant plate with the cell plate and start the assay. The instrument will measure baseline OCR before sequentially injecting the compounds and measuring the corresponding changes in OCR.
- Analyze the data to determine key parameters of mitochondrial respiration, such as basal respiration, ATP-linked respiration, maximal respiration, and non-mitochondrial oxygen consumption.

Mitochondrial Membrane Potential Assay (TMRE-Based)

This assay uses the fluorescent dye Tetramethylrhodamine, Ethyl Ester (TMRE) to assess mitochondrial membrane potential. TMRE accumulates in active mitochondria with an intact membrane potential.

Materials:

- TMRE stock solution (e.g., 1 mM in DMSO)
- Cell culture medium
- FCCP (carbonyl cyanide 4-(trifluoromethoxy)phenylhydrazone) as a positive control for depolarization
- Fluorescence microscope, flow cytometer, or microplate reader

Procedure (for fluorescence microscopy):

- Culture cells on glass-bottom dishes or chamber slides.
- Treat cells with the SDH inhibitor for the desired time. Include a positive control group treated with FCCP (e.g., 10 μ M for 10-15 minutes).

- Add TMRE to the culture medium to a final concentration of 20-500 nM (the optimal concentration should be determined empirically for each cell type).[19][20]
- Incubate the cells for 15-30 minutes at 37°C.[19][20]
- Replace the TMRE-containing medium with pre-warmed imaging buffer (e.g., PBS or HBSS).
- Image the cells immediately using a fluorescence microscope with appropriate filters for rhodamine. A decrease in red fluorescence intensity indicates a loss of mitochondrial membrane potential.

Application in Animal Models

SDH inhibitors are valuable tools for creating animal models of human diseases. The most prominent example is the use of 3-nitropropionic acid (3-NPA) to model Huntington's disease. Systemic administration of 3-NPA to rodents induces selective striatal degeneration, mimicking a key pathological feature of the disease.[10][14][21][22] This model is used to study the mechanisms of neurodegeneration and to test potential therapeutic interventions. Chronic administration of 3-NPA at low doses can reproduce both the hyperkinetic and hypokinetic symptoms observed in different stages of Huntington's disease.[10]

Conclusion

The inhibition of succinate dehydrogenase represents a potent strategy for modulating cellular metabolism and signaling. The profound effects of SDH inhibition on the TCA cycle, electron transport chain, and downstream pathways like HIF-1 α stabilization and ROS production underscore its importance as a therapeutic target and a tool for basic research. This guide provides a foundational understanding of SDH inhibition, offering quantitative data, detailed experimental protocols, and visual representations of the underlying biological processes. As research in this field continues to evolve, a thorough understanding of these core principles will be essential for the development of novel therapeutics and a deeper comprehension of cellular metabolism in health and disease.

Need Custom Synthesis?

BenchChem offers custom synthesis for rare earth carbides and specific isotopic labeling.

Email: info@benchchem.com or [Request Quote Online](#).

References

- 1. researchgate.net [researchgate.net]
- 2. mdpi.com [mdpi.com]
- 3. researchgate.net [researchgate.net]
- 4. researchgate.net [researchgate.net]
- 5. AOP-Wiki [aopwiki.org]
- 6. Computationally modeling mammalian succinate dehydrogenase kinetics identifies the origins and primary determinants of ROS production - PMC [pmc.ncbi.nlm.nih.gov]
- 7. Succinate accumulation induces mitochondrial reactive oxygen species generation and promotes status epilepticus in the kainic acid rat model - PMC [pmc.ncbi.nlm.nih.gov]
- 8. Malonic acid - Wikipedia [en.wikipedia.org]
- 9. caymanchem.com [caymanchem.com]
- 10. conductscience.com [conductscience.com]
- 11. Synthesis and Antineoplastic Evaluation of Mitochondrial Complex II (Succinate Dehydrogenase) Inhibitors Derived from Atpenin A5 - PMC [pmc.ncbi.nlm.nih.gov]
- 12. Atpenins, potent and specific inhibitors of mitochondrial complex II (succinate-ubiquinone oxidoreductase) - PMC [pmc.ncbi.nlm.nih.gov]
- 13. medchemexpress.com [medchemexpress.com]
- 14. The Mitochondrial Toxin 3-Nitropropionic Acid Induces Striatal Neurodegeneration via a c-Jun N-Terminal Kinase/c-Jun Module - PMC [pmc.ncbi.nlm.nih.gov]
- 15. Inhibition of Succinate Dehydrogenase by Pesticides (SDHIs) and Energy Metabolism - PMC [pmc.ncbi.nlm.nih.gov]
- 16. content.protocols.io [content.protocols.io]
- 17. tabaslab.com [tabaslab.com]
- 18. agilent.com [agilent.com]
- 19. assaygenie.com [assaygenie.com]
- 20. media.cellsignal.com [media.cellsignal.com]
- 21. [Model of Huntington's disease induced with 3-nitropropionic acid] - PubMed [pubmed.ncbi.nlm.nih.gov]

- 22. 3-Nitropropionic acid animal model and Huntington's disease - PubMed [pubmed.ncbi.nlm.nih.gov]
- To cite this document: BenchChem. [Sdh-IN-5 succinate dehydrogenase inhibition]. BenchChem, [2025]. [Online PDF]. Available at: [https://www.benchchem.com/product/b12383466#sdh-in-5-succinate-dehydrogenase-inhibition]

Disclaimer & Data Validity:

The information provided in this document is for Research Use Only (RUO) and is strictly not intended for diagnostic or therapeutic procedures. While BenchChem strives to provide accurate protocols, we make no warranties, express or implied, regarding the fitness of this product for every specific experimental setup.

Technical Support: The protocols provided are for reference purposes. Unsure if this reagent suits your experiment? [[Contact our Ph.D. Support Team for a compatibility check](#)]

Need Industrial/Bulk Grade? [Request Custom Synthesis Quote](#)

BenchChem

Our mission is to be the trusted global source of essential and advanced chemicals, empowering scientists and researchers to drive progress in science and industry.

Contact

Address: 3281 E Guasti Rd

Ontario, CA 91761, United States

Phone: (601) 213-4426

Email: info@benchchem.com