

Application Notes and Protocols for hCAXII-IN-7 in Cell Culture Experiments

Author: BenchChem Technical Support Team. **Date:** April 2026

Compound of Interest

Compound Name: hCAXII-IN-7

Cat. No.: B12383292

[Get Quote](#)

For Researchers, Scientists, and Drug Development Professionals

These application notes provide detailed protocols for the use of **hCAXII-IN-7**, a potent inhibitor of human carbonic anhydrase XII (hCA XII), in various cell culture experiments. The information is intended to guide researchers in investigating the biological effects of hCA XII inhibition in cancer cells and other relevant models.

Introduction to hCAXII-IN-7

hCAXII-IN-7, also identified as Carbonic Anhydrase Inhibitor 7 or compound 5b, is a small molecule inhibitor of human carbonic anhydrase (hCA) isoforms.[1] Carbonic anhydrase XII is a transmembrane enzyme that is overexpressed in various cancers and contributes to the regulation of the tumor microenvironment's pH, promoting cancer cell survival, proliferation, invasion, and metastasis.[2][3][4] Inhibition of hCA XII is a promising therapeutic strategy for cancer treatment.

hCAXII-IN-7 exhibits potent inhibitory activity against several hCA isoforms. Its inhibitory constants (K_i) are summarized in the table below.

Isoform	Ki (nM)
hCA I	255.8
hCA II	7.1
hCA IX	6.5
hCA XII	72.1

Table 1: Inhibitory activity (Ki) of hCAXII-IN-7 against various human carbonic anhydrase isoforms.[1]

A structurally related compound, referred to as C-10, which potently inhibits both hCA IX and hCA XII, has been shown to effectively reduce melanoma cell migration and invasion under hypoxic conditions.[5]

Preparation of hCAXII-IN-7 Stock Solution

For in vitro cell culture experiments, **hCAXII-IN-7** should be dissolved in a suitable solvent to prepare a concentrated stock solution.

Materials:

- **hCAXII-IN-7** powder
- Dimethyl sulfoxide (DMSO), cell culture grade

Protocol:

- Prepare a 10 mM stock solution of **hCAXII-IN-7** by dissolving the appropriate amount of the compound in DMSO. For example, for a compound with a molecular weight of 473.6 g/mol, dissolve 4.736 mg in 1 mL of DMSO.
- Ensure the compound is completely dissolved by vortexing.
- Aliquot the stock solution into smaller volumes to avoid repeated freeze-thaw cycles.

- Store the stock solution at -20°C for long-term use.

Note: The final concentration of DMSO in the cell culture medium should be kept low (typically $\leq 0.1\%$) to avoid solvent-induced cytotoxicity.

Cell-Based Assays

The following are detailed protocols for common cell-based assays to evaluate the effects of **hCAXII-IN-7**.

Cell Viability/Cytotoxicity Assay (MTT Assay)

This assay determines the effect of **hCAXII-IN-7** on cell viability and allows for the calculation of the half-maximal inhibitory concentration (IC₅₀).

Materials:

- Cancer cell line of interest (e.g., MCF-7, MDA-MB-231, HeLa)
- Complete cell culture medium
- **hCAXII-IN-7** stock solution (10 mM in DMSO)
- 96-well cell culture plates
- MTT (3-(4,5-dimethylthiazol-2-yl)-2,5-diphenyltetrazolium bromide) solution (5 mg/mL in PBS)
- DMSO

Protocol:

- Seed cells in a 96-well plate at a density of 5,000-10,000 cells/well in 100 μ L of complete medium and incubate for 24 hours.
- Prepare serial dilutions of **hCAXII-IN-7** in complete medium from the 10 mM stock solution. A suggested concentration range is 0.01, 0.1, 1, 10, 25, 50, and 100 μ M. Include a vehicle control (medium with 0.1% DMSO).

- Remove the medium from the wells and add 100 μ L of the prepared drug dilutions or vehicle control.
- Incubate the plate for 24, 48, or 72 hours at 37°C in a humidified incubator with 5% CO₂.
- After the incubation period, add 10 μ L of MTT solution to each well and incubate for 3-4 hours at 37°C, or until a purple precipitate is visible.
- Carefully remove the medium and add 100 μ L of DMSO to each well to dissolve the formazan crystals.
- Measure the absorbance at 570 nm using a microplate reader.
- Calculate the percentage of cell viability for each concentration relative to the vehicle control and determine the IC₅₀ value using appropriate software (e.g., GraphPad Prism).

Apoptosis Assay (Annexin V-FITC/PI Staining)

This flow cytometry-based assay detects apoptosis by identifying the externalization of phosphatidylserine (Annexin V) and loss of membrane integrity (Propidium Iodide).

Materials:

- Cancer cell line of interest
- 6-well cell culture plates
- **hCAXII-IN-7** stock solution (10 mM in DMSO)
- Annexin V-FITC Apoptosis Detection Kit (containing Annexin V-FITC, Propidium Iodide (PI), and Binding Buffer)
- Phosphate-buffered saline (PBS)
- Flow cytometer

Protocol:

- Seed cells in 6-well plates at an appropriate density to reach 70-80% confluency after 24 hours.
- Treat the cells with **hCAXII-IN-7** at concentrations around the determined IC50 value for 24 or 48 hours. Include a vehicle control.
- Harvest the cells by trypsinization, including the floating cells from the supernatant.
- Wash the cells twice with cold PBS by centrifugation at 300 x g for 5 minutes.
- Resuspend the cell pellet in 1X Binding Buffer at a concentration of 1×10^6 cells/mL.
- Transfer 100 μ L of the cell suspension (1×10^5 cells) to a flow cytometry tube.
- Add 5 μ L of Annexin V-FITC and 5 μ L of PI to the cell suspension.
- Gently vortex the cells and incubate for 15 minutes at room temperature in the dark.
- Add 400 μ L of 1X Binding Buffer to each tube.
- Analyze the samples by flow cytometry within one hour.

Western Blot Analysis

This technique is used to detect changes in the expression or phosphorylation status of proteins in signaling pathways affected by **hCAXII-IN-7**.

Materials:

- Cancer cell line of interest
- 6-well cell culture plates
- **hCAXII-IN-7** stock solution (10 mM in DMSO)
- RIPA lysis buffer supplemented with protease and phosphatase inhibitors
- BCA Protein Assay Kit

- SDS-PAGE gels and electrophoresis apparatus
- PVDF or nitrocellulose membranes and transfer apparatus
- Blocking buffer (e.g., 5% non-fat milk or BSA in TBST)
- Primary antibodies (e.g., anti-CAXII, anti-phospho-p38 MAPK, anti-p38 MAPK, anti-MMP-2, anti-MMP-9, anti- β -actin)
- HRP-conjugated secondary antibodies
- Enhanced chemiluminescence (ECL) substrate

Protocol:

- Seed cells in 6-well plates and grow to 70-80% confluency.
- Treat the cells with **hCAXII-IN-7** at the desired concentrations and for the appropriate time.
- Wash the cells with ice-cold PBS and lyse them with RIPA buffer.
- Scrape the cells and collect the lysate. Centrifuge at 14,000 x g for 15 minutes at 4°C to pellet cell debris.
- Determine the protein concentration of the supernatant using a BCA assay.
- Denature 20-30 μ g of protein per sample by boiling in Laemmli sample buffer.
- Separate the proteins by SDS-PAGE and transfer them to a PVDF or nitrocellulose membrane.
- Block the membrane with blocking buffer for 1 hour at room temperature.
- Incubate the membrane with the primary antibody overnight at 4°C.
- Wash the membrane with TBST and incubate with the HRP-conjugated secondary antibody for 1 hour at room temperature.

- Wash the membrane again with TBST and detect the protein bands using an ECL substrate and an imaging system.

Signaling Pathways and Experimental Workflows

CAXII Signaling Pathway

CAXII has been shown to promote cancer cell invasion and migration through the p38 MAPK signaling pathway.[3] Inhibition of CAXII can interfere with this pathway, leading to a reduction in the expression of matrix metalloproteinases (MMPs) like MMP-2 and MMP-9.[3]

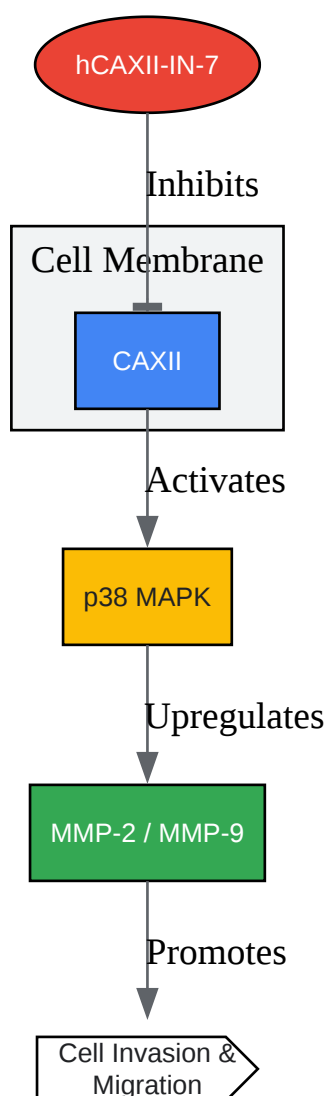

[Click to download full resolution via product page](#)

CAXII-p38 MAPK Signaling Pathway

Experimental Workflow for Evaluating hCAXII-IN-7

The following diagram illustrates a typical workflow for characterizing the in vitro effects of hCAXII-IN-7.

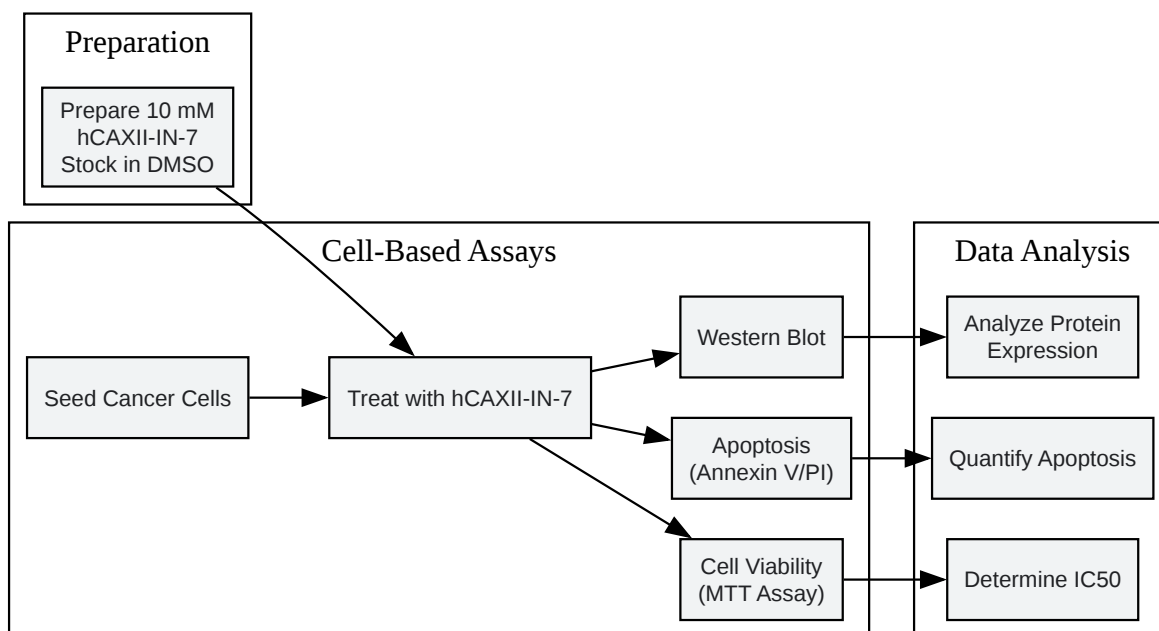

[Click to download full resolution via product page](#)

Workflow for hCAXII-IN-7 In Vitro Studies

Quantitative Data Summary

The following table summarizes key quantitative data for hCAXII-IN-7 and related compounds.

Compound	Target(s)	Ki (nM) for hCAXII	IC50	Cell Line	Assay	Reference
hCAXII-IN-7 (Compound 5b)	hCA I, II, IX, XII	72.1	Not Reported	Not Reported	-	[1]
hCAIX/XII-IN-7 (Compound 3e)	hCA I, II, IX, XII	59	Not Reported	Not Reported	-	-
C-10	hCA IX, hCA XII	Potent inhibitor	Not Reported	SK-MEL-28, A375	Migration, Invasion	[5]

Further experimental validation is required to determine the specific IC50 values of **hCAXII-IN-7** in various cancer cell lines.

Conclusion

These application notes provide a comprehensive guide for the use of **hCAXII-IN-7** in cell culture experiments. By following these protocols, researchers can effectively investigate the role of hCA XII in cancer biology and evaluate the therapeutic potential of its inhibition. It is recommended to optimize the experimental conditions, such as inhibitor concentration and incubation time, for each specific cell line and assay.

Need Custom Synthesis?

BenchChem offers custom synthesis for rare earth carbides and specific isotopic labeling.

Email: info@benchchem.com or [Request Quote Online](#).

References

- 1. [researchgate.net](https://www.researchgate.net) [[researchgate.net](https://www.researchgate.net)]

- [2. Overexpression of carbonic anhydrase IX induces cell motility by activating matrix metalloproteinase-9 in human oral squamous cell carcinoma cells - PMC \[pmc.ncbi.nlm.nih.gov\]](#)
- [3. Carbonic anhydrase XII promotes invasion and migration ability of MDA-MB-231 breast cancer cells through the p38 MAPK signaling pathway - PubMed \[pubmed.ncbi.nlm.nih.gov\]](#)
- [4. Targeting carbonic anhydrase IX and XII isoforms with small molecule inhibitors and monoclonal antibodies - PMC \[pmc.ncbi.nlm.nih.gov\]](#)
- [5. mdpi.com \[mdpi.com\]](#)
- To cite this document: BenchChem. [Application Notes and Protocols for hCAXII-IN-7 in Cell Culture Experiments]. BenchChem, [2026]. [Online PDF]. Available at: [\[https://www.benchchem.com/product/b12383292/docs#application-notes-and-protocols-for-hcaxii-in-7-in-cell-culture-experiments\]](https://www.benchchem.com/product/b12383292/docs#application-notes-and-protocols-for-hcaxii-in-7-in-cell-culture-experiments)

Disclaimer & Data Validity:

The information provided in this document is for Research Use Only (RUO) and is strictly not intended for diagnostic or therapeutic procedures. While BenchChem strives to provide accurate protocols, we make no warranties, express or implied, regarding the fitness of this product for every specific experimental setup.

Technical Support: The protocols provided are for reference purposes. Unsure if this reagent suits your experiment?

Need Industrial/Bulk Grade? [Request Custom Synthesis Quote](#)

BenchChem

Our mission is to be the trusted global source of essential and advanced chemicals, empowering scientists and researchers to drive progress in science and industry.

Contact

Address: 3281 E Guasti Rd
Ontario, CA 91761, United States
Phone: (601) 213-4426
Email: info@benchchem.com

Contact our Ph.D. Support Team for a compatibility check