

Application Notes and Protocols: Quantitative Analysis of CXCR2-Targeting PET Imaging Data

Author: BenchChem Technical Support Team. **Date:** April 2026

Compound of Interest

Compound Name: CXCR2 Probe 1

Cat. No.: B12383695

[Get Quote](#)

Audience: Researchers, scientists, and drug development professionals.

Introduction

The C-X-C chemokine receptor 2 (CXCR2) is a G-protein coupled receptor that plays a critical role in inflammation, angiogenesis, and tumor progression.^{[1][2][3]} Its ligands, including CXCL1, CXCL2, CXCL5, and CXCL8, are involved in the recruitment of neutrophils and other immune cells to sites of inflammation and within the tumor microenvironment.^{[3][4]} Given its involvement in various pathologies, CXCR2 has emerged as a significant target for therapeutic intervention and diagnostic imaging. Positron Emission Tomography (PET) is a highly sensitive, non-invasive imaging modality that allows for the quantitative assessment of biological processes in vivo. The development of PET probes targeting CXCR2 enables the visualization and quantification of its expression, which can aid in drug development, patient stratification, and monitoring therapeutic response.

These application notes provide detailed protocols for the quantitative analysis of PET imaging data obtained using a CXCR2-targeting probe, exemplified by a novel Fluorine-18 labeled tracer.

CXCR2 Signaling Pathway

Activation of CXCR2 by its cognate chemokines initiates a cascade of downstream signaling events that regulate cell migration, proliferation, and survival. Key pathways include the PI3K/Akt, MAPK/ERK, and STAT3 pathways, which collectively contribute to the biological functions mediated by this receptor. Understanding this pathway is crucial for interpreting the biological consequences of CXCR2 expression measured by PET.

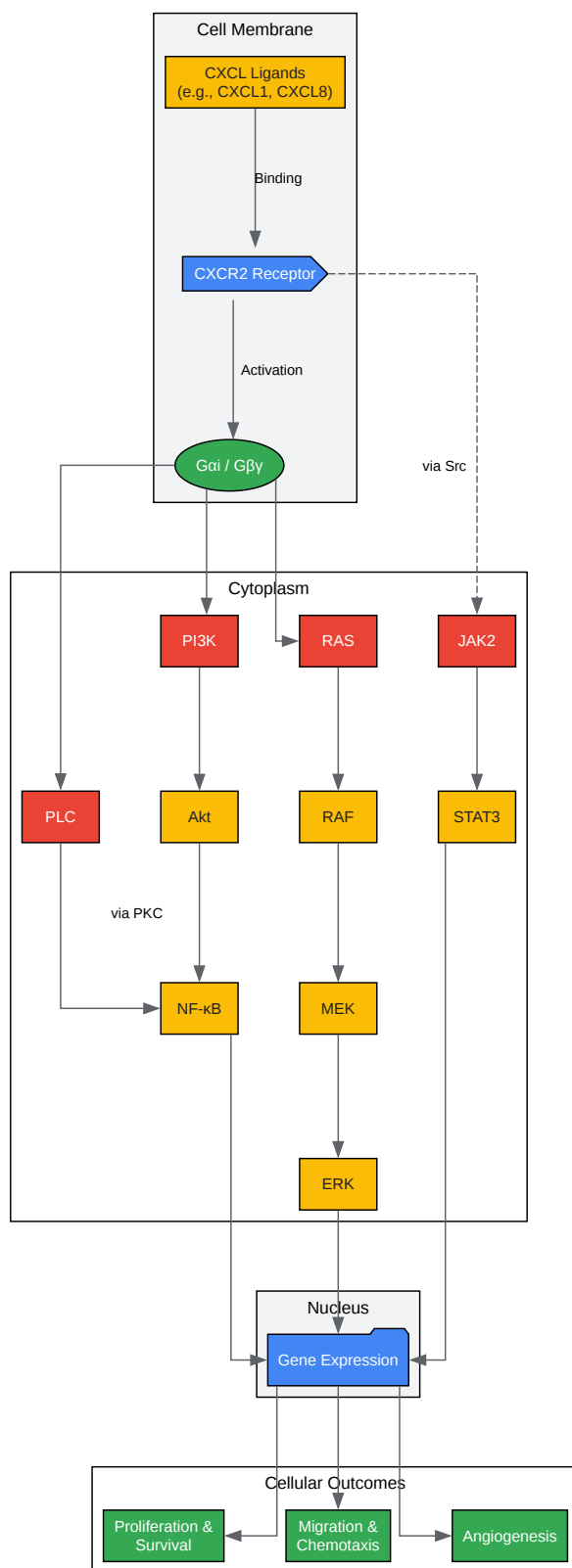

[Click to download full resolution via product page](#)

Caption: CXCR2 receptor signaling cascade.

Experimental Protocols & Workflows

A typical preclinical study involves several key stages: radiolabeling of the probe, quality control, in vitro validation, in vivo imaging of animal models, and ex vivo biodistribution for confirmation.

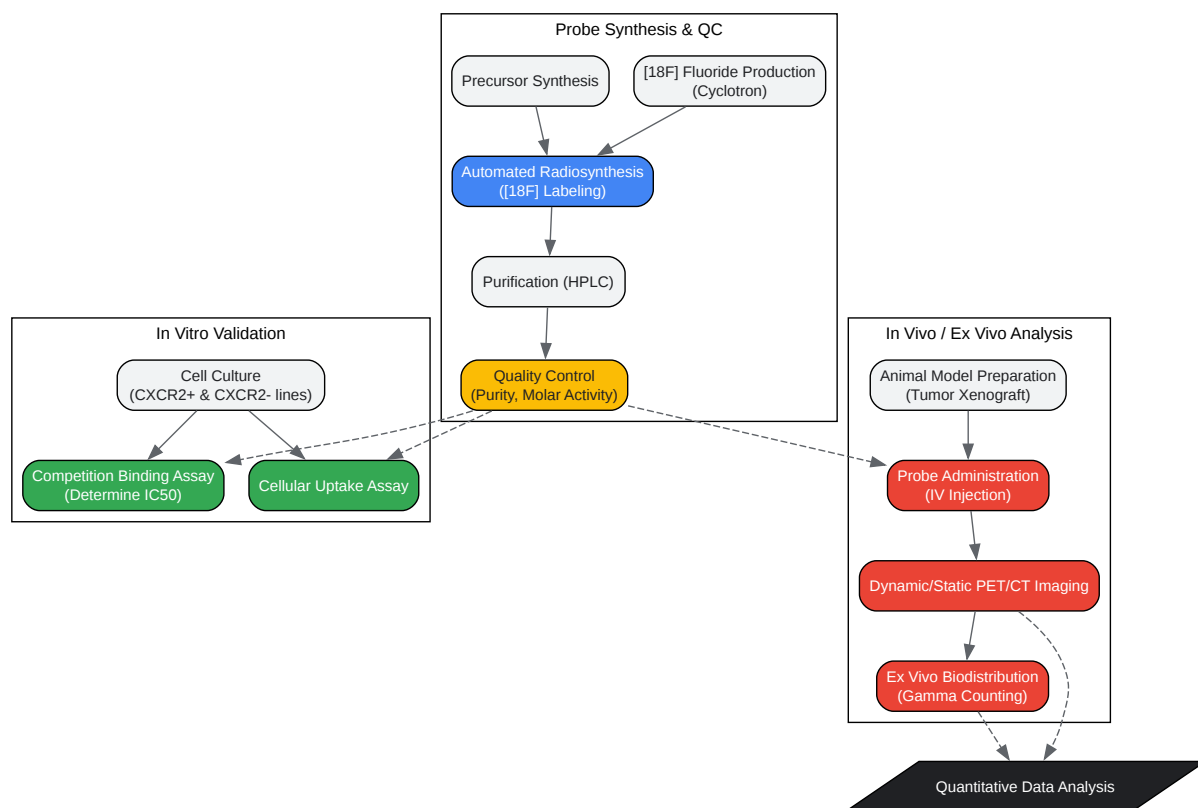

[Click to download full resolution via product page](#)

Caption: Overall experimental workflow.

Protocol 1: Radiosynthesis of an [^{18}F]-CXCR2 Probe

This protocol describes a general automated method for producing an ^{18}F -labeled CXCR2 probe, based on common radiolabeling techniques. A recently developed tracer, [^{18}F]16b, was synthesized with a radiochemical yield of 15%.

Objective: To radiolabel a precursor molecule with [^{18}F]Fluoride for use as a PET tracer.

Materials:

- Precursor for labeling (e.g., a tosyloxy- or nitro-substituted precursor).
- [^{18}F]Fluoride in [^{18}O]H₂O from a cyclotron.
- Automated radiosynthesis module (e.g., TRASIS AIO).
- Reagents: Acetonitrile (anhydrous), Kryptofix 2.2.2 (K222), Potassium Carbonate (K₂CO₃), Eluents for HPLC.
- Solid Phase Extraction (SPE) cartridges (e.g., C18).
- Sterile water for injection, USP.
- 0.9% Sodium Chloride for injection, USP.

Procedure:

- [^{18}F]Fluoride Trapping: Load the aqueous [^{18}F]Fluoride solution from the cyclotron onto a pre-conditioned anion exchange cartridge.
- Elution and Drying: Elute the trapped [^{18}F]F⁻ into the reaction vessel using a solution of K222/K₂CO₃ in acetonitrile/water. Dry the mixture azeotropically under a stream of nitrogen at ~110°C to form the reactive [^{18}F]F⁻/K/K222 complex.
- Radiolabeling Reaction: Dissolve the precursor molecule in a suitable anhydrous solvent (e.g., DMSO or acetonitrile) and add it to the dried [^{18}F]F⁻ complex. Heat the reaction mixture at a specified temperature (e.g., 120-150°C) for a set time (e.g., 10-20 minutes) to facilitate nucleophilic substitution.

- Purification: After the reaction, dilute the crude mixture with mobile phase and inject it onto a semi-preparative HPLC system to isolate the final radiolabeled product from unreacted fluoride and other impurities.
- Formulation: Collect the HPLC fraction containing the desired product. Remove the organic solvent via rotary evaporation or by trapping the product on a C18 SPE cartridge, washing with sterile water, and eluting with ethanol. Formulate the final product in a physiologically compatible solution (e.g., sterile saline with a low percentage of ethanol).
- Quality Control (QC):
 - Radiochemical Purity: Analyze an aliquot of the final product using analytical HPLC with a radiation detector.
 - Molar Activity (A_m): Measure the total radioactivity and the mass of the compound to calculate A_m (GBq/ μ mol).
 - pH and Sterility: Ensure the final product is within a physiological pH range (6.5-7.5) and perform sterility and endotoxin testing according to pharmacopeia standards.

Protocol 2: In Vivo PET/CT Imaging

Objective: To non-invasively quantify the biodistribution and tumor uptake of the CXCR2 probe in a preclinical model.

Materials:

- Tumor-bearing animal model (e.g., nude mouse with subcutaneous human cancer cell xenograft expressing CXCR2).
- Formulated [18 F]-CXCR2 Probe.
- Anesthesia (e.g., isoflurane).
- PET/CT scanner.
- Catheter for tail vein injection.

Procedure:

- **Animal Preparation:** Anesthetize the animal using isoflurane (e.g., 2% for induction, 1.5% for maintenance). Place the animal on the scanner bed with temperature monitoring and respiratory gating if available.
- **Tracer Administration:** Administer a known quantity of the [^{18}F]-CXCR2 Probe (e.g., 5-10 MBq) via tail vein injection.
- **CT Scan:** Perform a low-dose CT scan for anatomical co-registration and attenuation correction of the PET data.
- **PET Scan Acquisition:**
 - **Dynamic Scan:** For kinetic modeling, begin PET acquisition immediately after tracer injection and acquire data for 60-90 minutes.
 - **Static Scan:** For endpoint analysis, acquire a static PET scan at a specific time point post-injection (p.i.), typically when the optimal tumor-to-background ratio is achieved (e.g., 60 minutes p.i.). A typical acquisition time is 10-20 minutes.
- **Image Reconstruction:** Reconstruct the acquired PET data using an appropriate algorithm (e.g., OSEM3D), applying corrections for attenuation, scatter, and radioactive decay. The resulting images will display tracer concentration in units of Bq/mL.

Protocol 3: Ex Vivo Biodistribution and Gamma Counting

Objective: To provide a highly accurate, quantitative measure of tracer uptake in tissues, which serves as a gold standard to validate PET imaging data.

Materials:

- Calibrated gamma counter.
- Precision balance.

- Dissection tools.
- Vials for tissue collection.

Procedure:

- Study Groups: Following the final PET scan, or in a separate cohort of animals, euthanize the animals at designated time points p.i. (e.g., 30, 60, 120 minutes).
- Tissue Dissection: Immediately following euthanasia, rapidly dissect key organs and tissues of interest (e.g., tumor, blood, muscle, liver, spleen, kidneys, heart, lungs, bone, brain).
- Weighing and Counting:
 - Blot tissues to remove excess blood, weigh them, and place them in pre-tared vials.
 - Measure the radioactivity in each tissue sample using the gamma counter, along with standards prepared from a known fraction of the injected dose.
- Data Calculation: Calculate the tracer uptake in each tissue as the percentage of the injected dose per gram of tissue (%ID/g).
 - $\%ID/g = (\text{Tissue Counts} / \text{Injected Dose Counts}) / \text{Tissue Weight (g)} * 100$

Quantitative Data Analysis

Quantitative analysis transforms PET images into numerical data, allowing for objective assessment and comparison across subjects and studies.

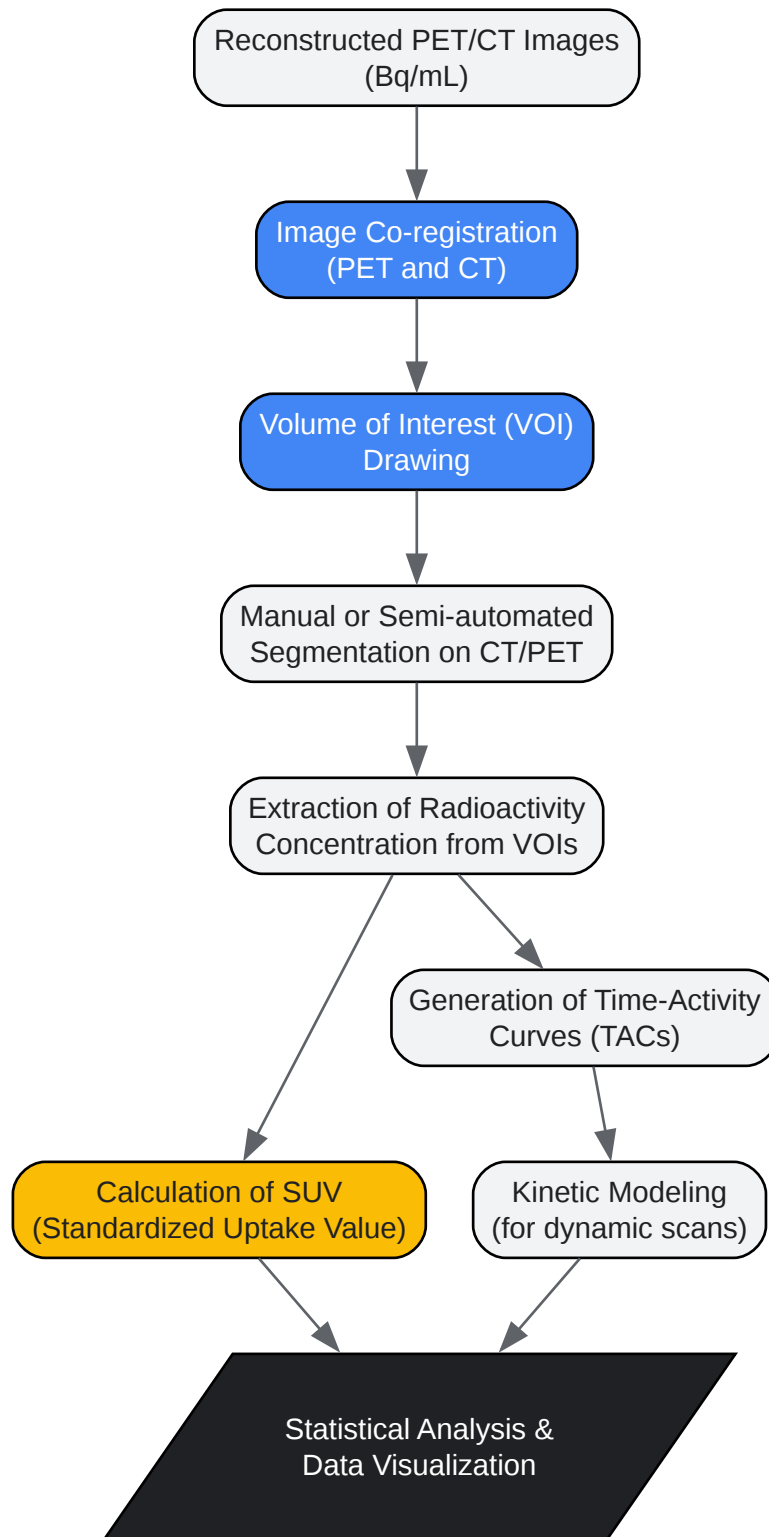

[Click to download full resolution via product page](#)

Need Custom Synthesis?

BenchChem offers custom synthesis for rare earth carbides and specific isotopic labeling.

Email: info@benchchem.com or [Request Quote Online](#).

References

- [1. The emerging role of chemokine receptor CXCR2 in cancer progression - Jaffer - Translational Cancer Research \[tcr.amegroups.org\]](#)
- [2. Design, Synthesis, and Application of Fluorescent Ligands Targeting the Intracellular Allosteric Binding Site of the CXC Chemokine Receptor 2 - PMC \[pmc.ncbi.nlm.nih.gov\]](#)
- [3. researchgate.net \[researchgate.net\]](#)
- [4. mdpi.com \[mdpi.com\]](#)
- To cite this document: BenchChem. [Application Notes and Protocols: Quantitative Analysis of CXCR2-Targeting PET Imaging Data]. BenchChem, [2026]. [Online PDF]. Available at: [<https://www.benchchem.com/product/b12383695/docs#application-notes-and-protocols-quantitative-analysis-of-cxcr2-targeting-pet-imaging-data>]

Disclaimer & Data Validity:

The information provided in this document is for Research Use Only (RUO) and is strictly not intended for diagnostic or therapeutic procedures. While BenchChem strives to provide accurate protocols, we make no warranties, express or implied, regarding the fitness of this product for every specific experimental setup.

Technical Support: The protocols provided are for reference purposes. Unsure if this reagent suits your experiment?

Need Industrial/Bulk Grade? [Request Custom Synthesis Quote](#)

BenchChem

Our mission is to be the trusted global source of essential and advanced chemicals, empowering scientists and researchers to drive progress in science and industry.

Contact

Address: 3281 E Guasti Rd
Ontario, CA 91761, United States
Phone: (601) 213-4426
Email: info@benchchem.com

[Contact our Ph.D. Support Team for a compatibility check](#)