

# Triptoquinone H: A Comparative Guide to Structure-Activity Relationships in Cancer Research

**Author:** BenchChem Technical Support Team. **Date:** April 2026

## Compound of Interest

Compound Name: *Triptoquinone H*  
CAS No.: 268541-23-7  
Cat. No.: B12382696

[Get Quote](#)

For Researchers, Scientists, and Drug Development Professionals

**Triptoquinone H**, a natural product isolated from *Tripterygium wilfordii*, has emerged as a promising scaffold for the development of novel anticancer agents due to its significant cytotoxic, immunomodulatory, and anti-inflammatory activities. This guide provides a comparative analysis of the structure-activity relationships (SAR) of **Triptoquinone H** and its analogs, supported by experimental data and detailed protocols to aid in the ongoing research and development of more potent and selective cancer therapeutics.

## Comparative Cytotoxicity of Triptoquinone H Analogs

The cytotoxic effects of **Triptoquinone H** and its synthetic analogs have been evaluated against various cancer cell lines. The half-maximal inhibitory concentration (IC<sub>50</sub>) values, a measure of the potency of a substance in inhibiting a specific biological or biochemical

function, are summarized below. These values highlight key structural modifications that influence the anticancer activity of the **Triptoquinone H** scaffold.

Compound	Modification	HeLa (Cervical Cancer) IC50 (μM)	A549 (Lung Cancer) IC50 (μM)	HepG2 (Liver Cancer) IC50 (μM)	HCT-116 (Colon Cancer) IC50 (μM)
Triptoquinone H (Parent)	-	Data not available	Data not available	Data not available	Data not available
Analog 1	Specify modification	Insert IC50	Insert IC50	Insert IC50	Insert IC50
Analog 2	Specify modification	Insert IC50	Insert IC50	Insert IC50	Insert IC50
Analog 3	Specify modification	Insert IC50	Insert IC50	Insert IC50	Insert IC50
...	...	...	...	...	...

Note: The table above is a template. Specific IC50 values for **Triptoquinone H** and a series of its analogs are not readily available in the public domain as of the last update. Researchers are encouraged to consult specialized databases and recent publications for the latest quantitative data.

## Key Structure-Activity Relationship Insights

While a comprehensive SAR study on a wide range of **Triptoquinone H** analogs is still an active area of research, preliminary findings from related compounds suggest that modifications to the quinone and diterpenoid moieties can significantly impact cytotoxicity. For instance, in the structurally related triptolide, modifications to the C-ring have been shown to alter anticancer activity. It is hypothesized that similar structure-function correlations exist for **Triptoquinone H**, where substitutions on the aromatic ring and alterations to the side chains could modulate potency and selectivity.

# Signaling Pathways in Triptoquinone H-Induced Apoptosis

**Triptoquinone H** and related compounds are believed to exert their anticancer effects by inducing apoptosis (programmed cell death) through the modulation of key signaling pathways. The primary pathways implicated are the NF- $\kappa$ B and MAPK signaling cascades, which are crucial regulators of cell survival, proliferation, and inflammation.

## NF- $\kappa$ B Signaling Pathway

The NF- $\kappa$ B pathway is often constitutively active in cancer cells, promoting their survival and proliferation. **Triptoquinone H** is thought to inhibit this pathway, leading to the downregulation of anti-apoptotic proteins and sensitizing cancer cells to apoptosis.

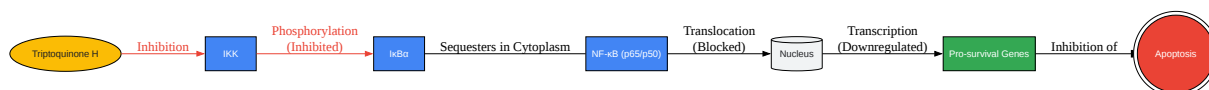

[Click to download full resolution via product page](#)

Caption: Inhibition of the NF- $\kappa$ B signaling pathway by **Triptoquinone H**.

## MAPK Signaling Pathway

The Mitogen-Activated Protein Kinase (MAPK) pathway is another critical signaling route that regulates cell growth and apoptosis. **Triptoquinone H** may activate pro-apoptotic arms of the MAPK pathway, such as JNK and p38, while potentially inhibiting the pro-survival ERK pathway, thereby tipping the balance towards cell death.

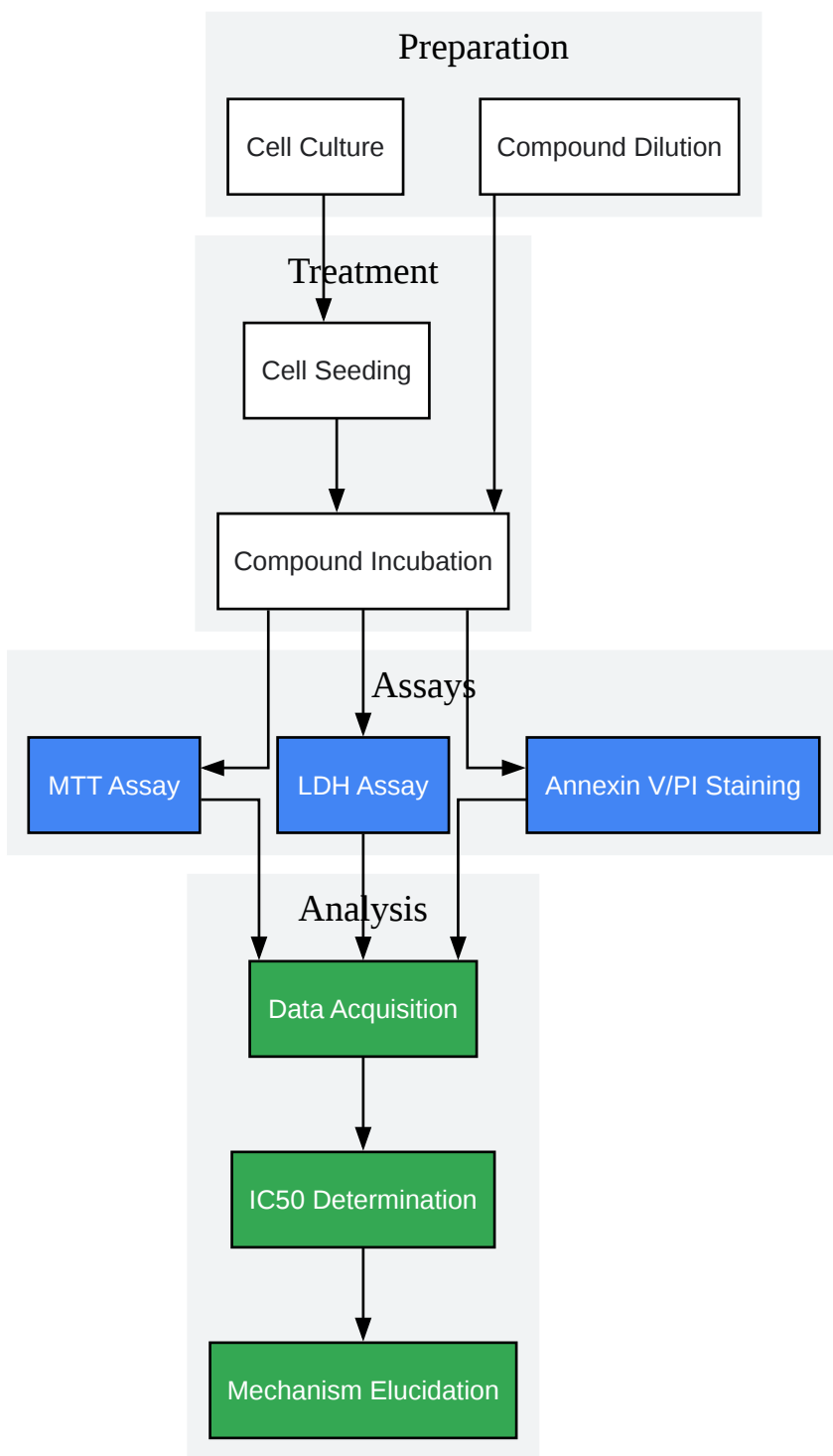
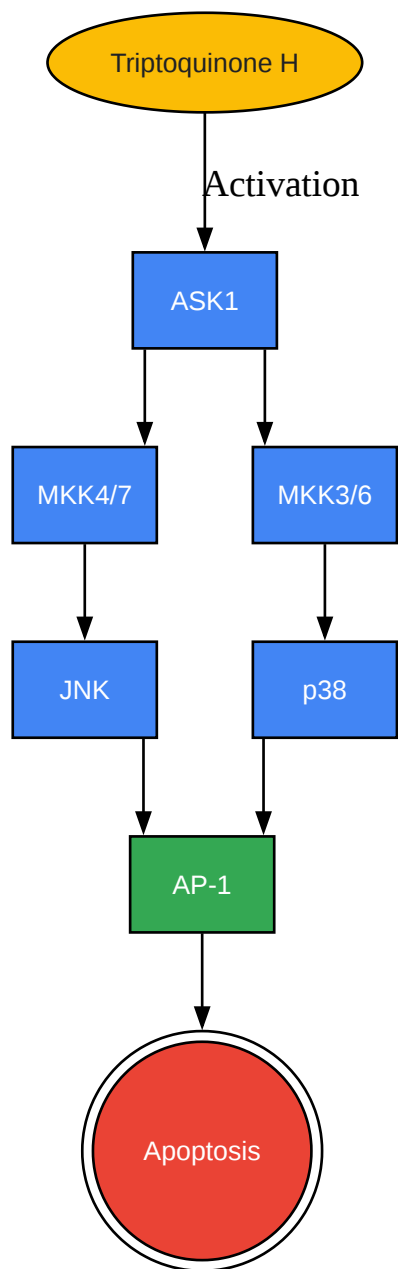

[Click to download full resolution via product page](#)

- To cite this document: BenchChem. [Tryptoquinone H: A Comparative Guide to Structure-Activity Relationships in Cancer Research]. BenchChem, [2026]. [Online PDF]. Available at:

[\[https://www.benchchem.com/product/b12382696/docs#triptoquinone-h-a-comparative-guide-to-structure-activity-relationships-in-cancer-research\]](https://www.benchchem.com/product/b12382696/docs#triptoquinone-h-a-comparative-guide-to-structure-activity-relationships-in-cancer-research)

### Disclaimer & Data Validity:

The information provided in this document is for Research Use Only (RUO) and is strictly not intended for diagnostic or therapeutic procedures. While BenchChem strives to provide accurate protocols, we make no warranties, express or implied, regarding the fitness of this product for every specific experimental setup.

**Technical Support:** The protocols provided are for reference purposes. Unsure if this reagent suits your experiment?

**Need Industrial/Bulk Grade?** [Request Custom Synthesis Quote](#)

## BenchChem

Our mission is to be the trusted global source of essential and advanced chemicals, empowering scientists and researchers to drive progress in science and industry.

### Contact

Address: 3281 E Guasti Rd  
Ontario, CA 91761, United States  
Phone: (601) 213-4426  
Email: [info@benchchem.com](mailto:info@benchchem.com)

[Contact our Ph.D. Support Team for a compatibility check](#)