

Technical Support Center: (R)-DZD1516 Animal Model Studies

Author: BenchChem Technical Support Team. **Date:** April 2026

Compound of Interest

Compound Name: (R)-DZD1516

Cat. No.: B12382435

[Get Quote](#)

This technical support center provides troubleshooting guides and frequently asked questions (FAQs) for researchers, scientists, and drug development professionals utilizing **(R)-DZD1516** in animal models. The information is designed to help manage potential adverse effects and ensure the successful execution of preclinical experiments.

Frequently Asked Questions (FAQs)

Q1: What is **(R)-DZD1516** and what is its primary mechanism of action?

A1: **(R)-DZD1516** is an orally bioavailable, reversible, and highly selective inhibitor of the human epidermal growth factor receptor 2 (HER2) tyrosine kinase.^[1] Its primary mechanism is to bind to the ATP-binding site of the HER2 protein, preventing its phosphorylation and blocking downstream signaling pathways. This inhibition leads to suppressed proliferation and apoptosis in HER2-overexpressing tumor cells. A key feature of **(R)-DZD1516** is its ability to penetrate the blood-brain barrier (BBB), making it a candidate for treating CNS metastases.^{[2][3]}

Q2: What are the most common adverse effects observed with **(R)-DZD1516** in preclinical and clinical studies?

A2: Based on clinical data from a phase 1 study, the most frequently reported treatment-related adverse events are headache, vomiting, nausea, and decreased hemoglobin.[2][4][5][6]

Notably, due to its high selectivity for HER2 over the epidermal growth factor receptor (EGFR), **(R)-DZD1516** does not typically cause the diarrhea or skin rash commonly associated with other less selective HER2 tyrosine kinase inhibitors at doses up to 250 mg twice daily.[2][3][4][5] While specific adverse event rates in animal models are not detailed in published literature, researchers should closely monitor for analogous clinical signs.

Q3: In which animal models has **(R)-DZD1516** been evaluated?

A3: **(R)-DZD1516** has been evaluated in various preclinical animal models, including mice, rats, and monkeys.[1][2] Efficacy studies have predominantly used xenograft mouse models with HER2-positive cancer cell lines to establish subcutaneous tumors and intracranial models of brain and leptomeningeal metastases.[2][4] Pharmacokinetic and CNS penetration studies have been conducted in rats and monkeys.[1][2]

Q4: What is the significance of **(R)-DZD1516**'s high selectivity for HER2 over EGFR?

A4: The high selectivity of **(R)-DZD1516** for HER2 over wild-type EGFR (over 300-fold) is a critical design feature.[3] Inhibition of EGFR is associated with toxicities such as severe diarrhea and skin rash, which are dose-limiting side effects for many other tyrosine kinase inhibitors.[7] By avoiding EGFR inhibition, **(R)-DZD1516** is expected to have a more favorable safety profile, potentially allowing for more consistent dosing and better tolerability in animal subjects.[3][7]

Troubleshooting Guides for Adverse Effects in Animal Models

This section provides guidance on identifying and managing potential adverse effects during in vivo studies with **(R)-DZD1516**. The recommendations are based on translating clinical observations to preclinical research settings.

Issue 1: Neurological Signs (Potential correlate for headache/CNS effects)

- How to Identify:

- Behavioral Changes: Observe for signs of pain or discomfort, which may include orbital tightening, grimacing, abnormal posture (hunching), reduced exploratory activity, or light/sound sensitivity.[8][9]
- General Activity: Monitor for lethargy, decreased grooming, or changes in interaction with cage mates.
- Food and Water Intake: A sudden decrease in consumption can be an indicator of general malaise or nausea.[8]
- Management and Troubleshooting:
 - Rule out other causes: Ensure that the observed signs are not due to other experimental factors, such as the tumor burden, surgical procedures, or other co-administered agents.
 - Provide Supportive Care:
 - Ensure easy access to softened food or gel-based hydration to encourage intake.
 - Minimize environmental stressors such as loud noises, bright lights, and excessive handling.
 - Consider Analgesia: If signs of pain are evident and interfere with animal welfare, consult with the institutional veterinarian about appropriate analgesic options that will not confound experimental results.
 - Dose Modification: If severe neurological signs are observed across a cohort and are likely drug-related, consider a dose reduction or a temporary pause in dosing, in consultation with the study director.

Issue 2: Gastrointestinal Upset (Potential correlate for nausea/vomiting)

- How to Identify:
 - Changes in Food Consumption: Significant reduction in food intake is a primary indicator.
 - Weight Loss: Monitor body weight daily. Acute weight loss can signal GI upset.

- Pica: Observe for the eating of non-nutritive substances like bedding, which can be a sign of nausea in rodents.
- Observation: While rodents cannot vomit, they may exhibit conditioned taste aversion.[9]
- Management and Troubleshooting:
 - Dietary Support: Provide highly palatable, soft, and moist food. Supplement with hydration gels.
 - Anti-emetic Therapy: For severe cases, and where it does not interfere with the study's primary endpoints, consultation with a veterinarian for anti-emetic treatment may be warranted.
 - Vehicle Control Check: Ensure the vehicle used for oral gavage is not causing local irritation or distress. Administering the vehicle to a control group is essential.
 - Dosing Procedure Review: Ensure proper oral gavage technique to minimize stress and potential for esophageal irritation.

Issue 3: Hematological Effects (Potential correlate for decreased hemoglobin/anemia)

- How to Identify:
 - Physical Signs: Observe for pale mucous membranes (paws, nose, ears) and decreased activity or lethargy.
 - Blood Analysis: Conduct periodic complete blood counts (CBCs) from satellite animal groups or at terminal time points as planned in the study protocol. A decrease in hemoglobin, hematocrit, and red blood cell count is indicative of anemia.[10][11]
- Management and Troubleshooting:
 - Scheduled Monitoring: Implement a regular blood monitoring schedule to detect the onset and severity of anemia.

- **Nutritional Support:** Ensure the diet is fortified with essential nutrients for hematopoiesis, such as iron and B vitamins.
- **Address Potential Blood Loss:** In tumor-bearing models, rule out tumor-related hemorrhage as a contributing factor.
- **Dose Adjustment:** If severe, drug-induced anemia is confirmed, a dose reduction may be necessary to allow for hematopoietic recovery.
- **Blood Transfusion:** In critical and valuable animal models, a blood transfusion may be considered in consultation with veterinary staff, though this is an extreme measure and may affect experimental outcomes.[\[1\]](#)

Quantitative Data Summary

Table 1: In Vitro Potency and Selectivity of **(R)-DZD1516**

Parameter	Cell Line / Assay	IC50 / GI50	Selectivity
HER2 Kinase Inhibition	Enzymatic Assay	0.56 nM	-
pHER2 Inhibition	BT474C1 (HER2+)	4.4 nM	>300-fold vs. pEGFR
pEGFR Inhibition	A431 (EGFR wt)	1455 nM	
Cell Proliferation (HER2+)	BT474C1	20 nM	>440-fold vs. EGFR wt
Cell Proliferation (EGFR wt)	A431	8867 nM	

Data sourced from preclinical studies.[\[2\]](#)

Table 2: Summary of Adverse Events in Phase 1 Human Study (Doses ≤ 250 mg BID)

Adverse Event	Frequency	Grade	Notes
Headache	Most Common	Grade 1/2	Manageable and reversible.
Vomiting	Common	Grade 1/2	Manageable and reversible.
Hemoglobin Decreased	Common	Grade 1/2	Monitored via blood tests.
Nausea	Reported	Grade 1/2	Manageable and reversible.
Diarrhea	Not Observed	-	Consistent with high selectivity over EGFR.
Skin Rash	Not Observed	-	Consistent with high selectivity over EGFR.

Data reflects clinical observations which may inform preclinical monitoring.[\[2\]](#)[\[5\]](#)[\[6\]](#)[\[12\]](#)

Experimental Protocols

Protocol 1: In Vivo Efficacy Assessment in a Brain Metastasis Xenograft Model

- Cell Line: BT474C1 human breast cancer cells engineered to express luciferase.
- Animal Model: Female nude mice (e.g., BALB/c nude).
- Tumor Implantation:
 - Anesthetize mice using a suitable anesthetic (e.g., isoflurane).
 - Secure the mouse in a stereotactic frame.
 - Inject approximately 2×10^5 BT474C1-Luci cells intracerebrally into the right cerebral hemisphere.

- Tumor Growth Monitoring:
 - Monitor tumor growth via bioluminescent imaging (BLI) once or twice weekly.
 - Administer luciferin intraperitoneally and image animals 10-15 minutes post-injection using an in vivo imaging system (IVIS).
- Treatment Initiation:
 - When tumor BLI signal reaches a predetermined threshold, randomize animals into treatment and control groups.
- Drug Administration:
 - Prepare **(R)-DZD1516** in a suitable vehicle (e.g., 0.5% methylcellulose).
 - Administer **(R)-DZD1516** via oral gavage at specified doses (e.g., 100 mg/kg, 150 mg/kg) and schedule (e.g., twice daily).
 - The control group receives the vehicle only.
- Endpoint and Analysis:
 - Continue treatment for a defined period (e.g., 21-28 days).
 - Monitor animal body weight and clinical signs daily.
 - Measure tumor burden via BLI regularly.
 - The primary endpoint is tumor growth inhibition (TGI). Euthanize animals if they reach humane endpoints (e.g., >20% body weight loss, significant neurological signs).

Mandatory Visualizations

Signaling Pathway

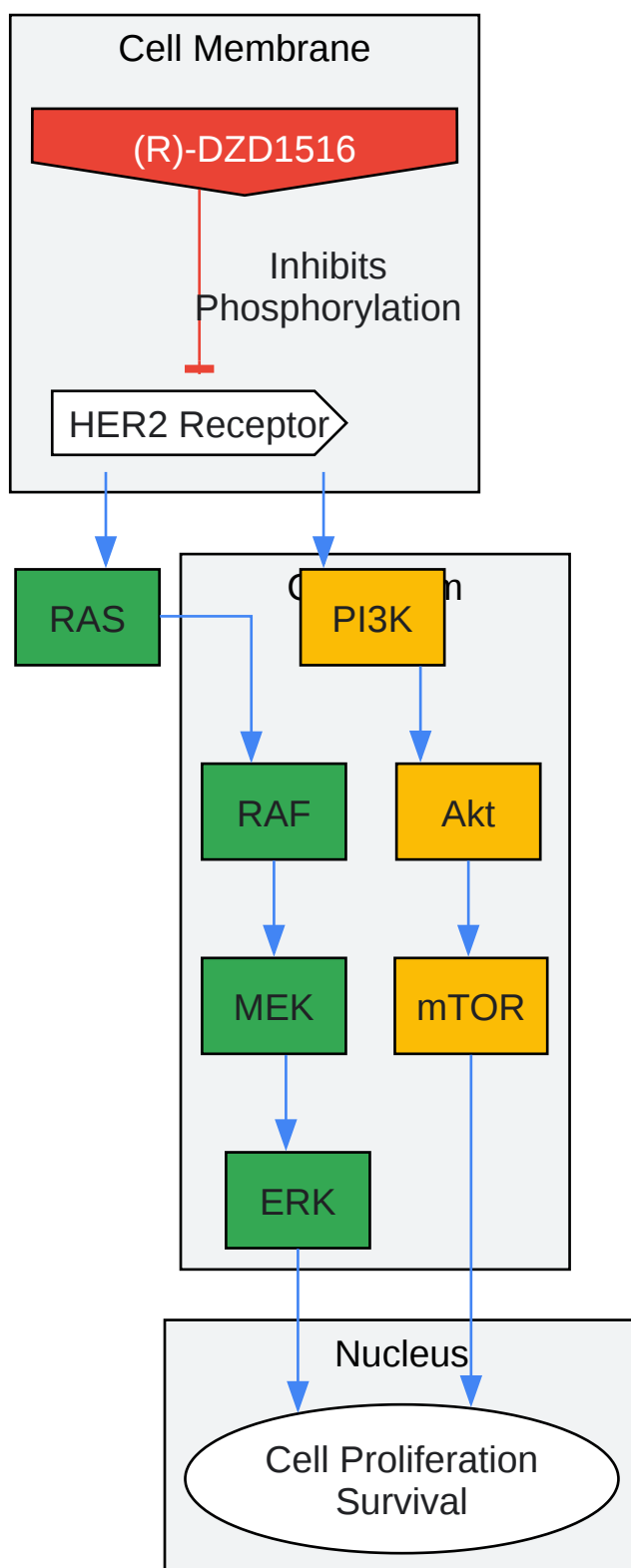

[Click to download full resolution via product page](#)

Caption: **(R)-DZD1516** inhibits HER2 phosphorylation, blocking downstream PI3K/Akt and MAPK pathways.

Experimental Workflow

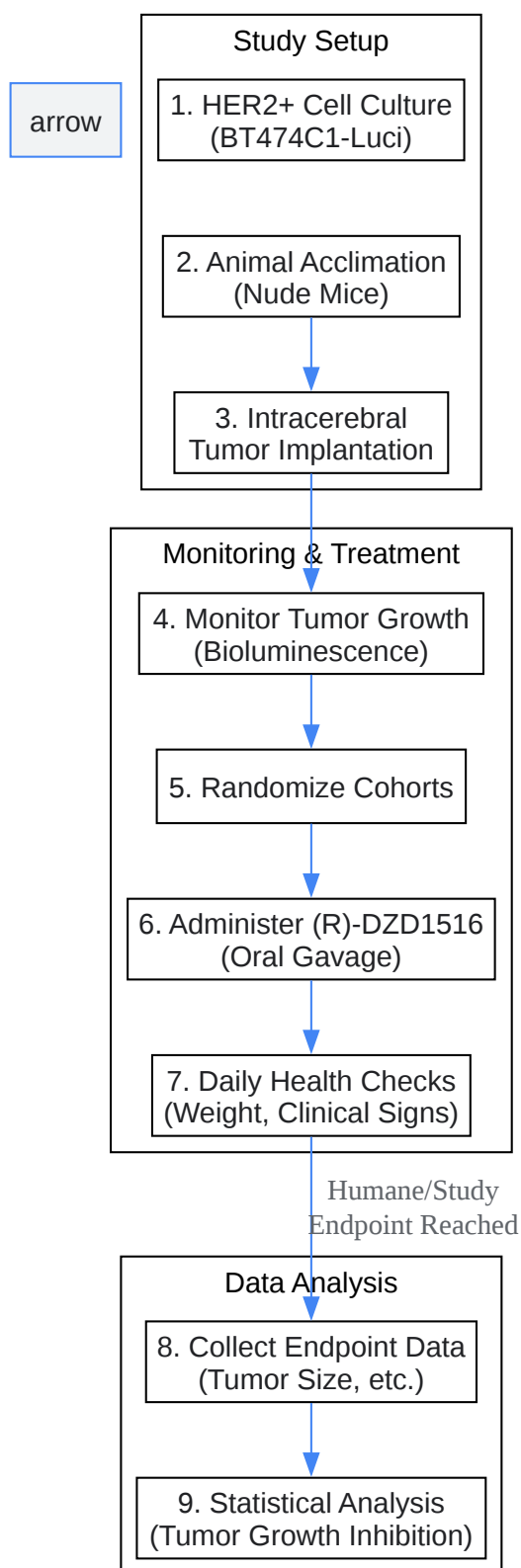

[Click to download full resolution via product page](#)

Caption: Workflow for assessing **(R)-DZD1516** efficacy in a brain metastasis mouse model.

Troubleshooting Logic

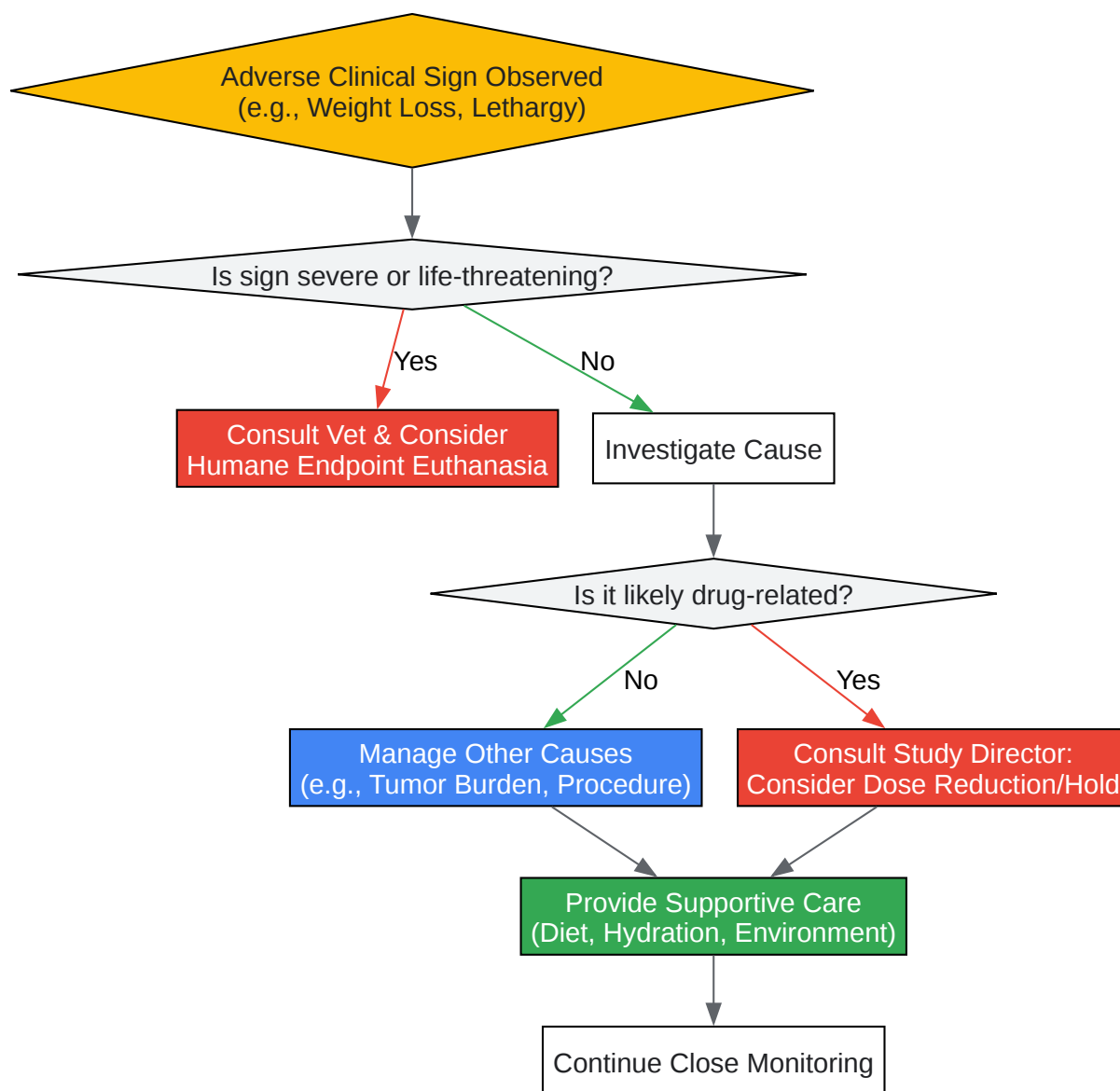

[Click to download full resolution via product page](#)

Caption: Decision-making flowchart for managing adverse events in animal studies.

Need Custom Synthesis?

BenchChem offers custom synthesis for rare earth carbides and specific isotopic labeling.

Email: info@benchchem.com or [Request Quote Online](#).

References

- 1. Iron deficiency anemia - PMC [[pmc.ncbi.nlm.nih.gov](https://pubmed.ncbi.nlm.nih.gov/)]
- 2. HER2 Tx Toxicities | Decera Clinical Education [deceraclinical.com]
- 3. [researchgate.net](https://www.researchgate.net/) [[researchgate.net](https://www.researchgate.net/)]
- 4. Neurotoxicity, behavioral changes and gene-expression profile of mice exposed to SnS2 nanoflowers - PMC [[pmc.ncbi.nlm.nih.gov](https://pubmed.ncbi.nlm.nih.gov/)]
- 5. Neurotoxicity: Definition, causes, and more [[medicalnewstoday.com](https://www.medicalnewstoday.com/)]
- 6. New insights in animal models of neurotoxicity-induced neurodegeneration - PMC [[pmc.ncbi.nlm.nih.gov](https://pubmed.ncbi.nlm.nih.gov/)]
- 7. [awionline.org](https://www.awionline.org/) [[awionline.org](https://www.awionline.org/)]
- 8. Behavioral and cognitive animal models in headache research - PMC [[pmc.ncbi.nlm.nih.gov](https://pubmed.ncbi.nlm.nih.gov/)]
- 9. [researchgate.net](https://www.researchgate.net/) [[researchgate.net](https://www.researchgate.net/)]
- 10. Overview of Anemia in Animals - Circulatory System - MSD Veterinary Manual [[msdsvetmanual.com](https://www.msdsvetmanual.com/)]
- 11. [boule.com](https://www.boule.com/) [[boule.com](https://www.boule.com/)]
- 12. EGFR and HER2 small molecules inhibitors as potential therapeutics in veterinary oncology [scielo.org.co]
- To cite this document: BenchChem. [Technical Support Center: (R)-DZD1516 Animal Model Studies]. BenchChem, [2026]. [Online PDF]. Available at: [<https://www.benchchem.com/product/b12382435/docs#technical-support-center-r-dzd1516-animal-model-studies>]

Disclaimer & Data Validity:

The information provided in this document is for Research Use Only (RUO) and is strictly not intended for diagnostic or therapeutic procedures. While BenchChem strives to provide accurate protocols, we make no warranties, express or implied, regarding the fitness of this product for every specific experimental setup.

Technical Support: The protocols provided are for reference purposes. Unsure if this reagent suits your experiment?

Need Industrial/Bulk Grade? [Request Custom Synthesis Quote](#)

BenchChem

Our mission is to be the trusted global source of essential and advanced chemicals, empowering scientists and researchers to drive progress in science and industry.

Contact

Address: 3281 E Guasti Rd
Ontario, CA 91761, United States
Phone: (601) 213-4426
Email: info@benchchem.com

[Contact our Ph.D. Support Team for a compatibility check](#)