

Technical Support Center: Optimizing UNC8900 Concentration for Experiments

Author: BenchChem Technical Support Team. **Date:** April 2026

Compound of Interest

Compound Name: UNC8900

Cat. No.: B12382066

[Get Quote](#)

Welcome to the technical support center for **UNC8900**. This resource is designed for researchers, scientists, and drug development professionals to provide guidance on optimizing the experimental use of **UNC8900**, a novel and potent inhibitor of the PI3K/Akt/mTOR signaling pathway. Here you will find troubleshooting guides and frequently asked questions (FAQs) to ensure the successful application of **UNC8900** in your research.

Frequently Asked Questions (FAQs)

Q1: What is **UNC8900** and what is its mechanism of action?

A1: **UNC8900** is a selective, small molecule inhibitor targeting the Phosphoinositide 3-kinase (PI3K) family of lipid kinases. The PI3K/Akt/mTOR pathway is a crucial intracellular signaling cascade that regulates a wide range of cellular processes including cell growth, proliferation, survival, and metabolism.[1][2][3] In many cancers, this pathway is hyperactivated, contributing to tumor progression.[4] **UNC8900** inhibits PI3K, thereby blocking the downstream activation of Akt and mTOR, leading to a reduction in cell proliferation and survival in cancer cells with a dysregulated PI3K/Akt/mTOR pathway.[2][4]

Q2: What is the recommended starting concentration for **UNC8900** in cell culture experiments?

A2: The optimal concentration of **UNC8900** is highly dependent on the cell line and the specific experimental endpoint. For initial experiments, a wide concentration range should be tested to determine the half-maximal inhibitory concentration (IC₅₀). A common starting point for potent kinase inhibitors is in the low nanomolar to low micromolar range.[5] We recommend performing a dose-response curve starting from 1 nM to 10 μM to establish the effective concentration for your specific cell model.

Q3: How should I prepare and store **UNC8900** stock solutions?

A3: **UNC8900** is soluble in dimethyl sulfoxide (DMSO). It is recommended to prepare a high-concentration stock solution (e.g., 10 mM) in anhydrous DMSO.[6] This stock solution should be aliquoted into single-use volumes to minimize freeze-thaw cycles and stored at -20°C or -80°C for long-term stability. When preparing working solutions, dilute the stock directly into your cell culture medium. It is critical to ensure that the final DMSO concentration in your experimental wells does not exceed a level that could cause solvent-induced toxicity, typically ≤ 0.1%.[6]

Q4: How can I confirm that **UNC8900** is inhibiting the PI3K/Akt/mTOR pathway in my cells?

A4: The most direct method to confirm the on-target activity of **UNC8900** is to perform a Western blot analysis of key downstream effectors of the PI3K/Akt/mTOR pathway.[7] Specifically, you should assess the phosphorylation status of Akt (at Ser473 and Thr308) and downstream targets of mTOR, such as S6 ribosomal protein or 4E-BP1.[2] A significant decrease in the phosphorylation of these proteins following **UNC8900** treatment would confirm target engagement.

Troubleshooting Guides

Issue 1: No observable effect of **UNC8900** on my cells.

Possible Cause	Troubleshooting Step	Expected Outcome
Inactive PI3K/Akt/mTOR pathway in the selected cell line.	Verify the baseline phosphorylation status of Akt and S6 in your untreated cell lysates via Western blot.	If the pathway is not active, UNC8900 will not have a significant effect. Consider using a cell line with a known PI3K pathway mutation or activation.
Insufficient inhibitor concentration or incubation time.	Perform a dose-response (e.g., 1 nM to 10 μ M) and a time-course (e.g., 1, 6, 12, 24 hours) experiment. ^[6]	To identify the optimal concentration and duration required to observe an effect.
Degraded UNC8900.	Prepare fresh working solutions from a new aliquot of the stock solution for each experiment. Ensure proper storage of stock solutions at -20°C or -80°C. ^[6]	A fresh inhibitor solution should restore activity if degradation was the issue.
High cell confluence.	Ensure that cells are in the logarithmic growth phase and are not overly confluent at the time of treatment. ^[6]	Cells in an optimal growth phase are more sensitive to pathway inhibition.

Issue 2: Significant cytotoxicity observed even at low concentrations.

Possible Cause	Troubleshooting Step	Expected Outcome
The cell line is highly dependent on the PI3K/Akt/mTOR pathway for survival.	This may be an expected on-target effect. Correlate the cytotoxicity with the inhibition of p-Akt to confirm.	The cytotoxic effect should directly correspond with the degree of pathway inhibition.
Off-target effects.	While UNC8900 is designed to be selective, off-target effects can occur at higher concentrations. Lower the concentration of UNC8900. ^[6] Consider using a structurally different PI3K inhibitor to see if the same phenotype is observed. ^[8]	If cytotoxicity persists with a different inhibitor, it is likely an on-target effect.
Solvent toxicity.	Ensure the final DMSO concentration is at a non-toxic level (typically $\leq 0.1\%$). Run a vehicle control with the highest concentration of DMSO used in your experiment. ^[6]	The vehicle control should show no significant cytotoxicity.

Experimental Protocols

Protocol 1: Dose-Response Experiment to Determine IC50

This protocol outlines the steps to determine the concentration of **UNC8900** that inhibits a biological response by 50%.

- Cell Seeding:
 - Trypsinize and count your cells, ensuring they are healthy and in the log growth phase.
 - Seed the cells in a 96-well plate at a predetermined optimal density for your cell line. Allow cells to attach and resume growth for 24 hours.

- Inhibitor Preparation and Treatment:
 - Prepare a 10 mM stock solution of **UNC8900** in DMSO.
 - Perform serial dilutions of the **UNC8900** stock in complete culture medium to achieve the desired final concentrations (e.g., a 10-point, 3-fold dilution series starting from 10 μ M).
 - Include a vehicle control (medium with the same final DMSO concentration as the highest **UNC8900** concentration) and a no-treatment control.
 - Remove the medium from the cells and add the prepared inhibitor dilutions and controls. Each condition should be performed in triplicate.
- Incubation:
 - Incubate the plate for a predetermined duration (e.g., 72 hours), which should be optimized for your cell line and assay.
- Cell Viability Assay:
 - Assess cell viability using a suitable method, such as a resazurin-based assay or CellTiter-Glo®.
- Data Analysis:
 - Normalize the data to the vehicle control.
 - Plot the normalized response against the log of the inhibitor concentration and fit the data to a four-parameter logistic (4PL) non-linear regression model to determine the IC50 value.^[9]

Protocol 2: Western Blot for Target Engagement

This protocol describes how to verify the inhibition of the PI3K/Akt/mTOR pathway by **UNC8900**.

- Cell Treatment:

- Seed cells in 6-well plates and allow them to attach overnight.
- Treat the cells with **UNC8900** at various concentrations (e.g., 0.1x, 1x, and 10x the determined IC50) and a vehicle control for an optimized duration (e.g., 2-4 hours).
- Cell Lysis:
 - Wash the cells with ice-cold PBS.
 - Lyse the cells in RIPA buffer supplemented with protease and phosphatase inhibitor cocktails to preserve the phosphorylation state of proteins.[\[10\]](#)
 - Keep samples on ice throughout the lysis procedure.[\[10\]](#)
- Protein Quantification:
 - Determine the protein concentration of each lysate using a BCA assay.
- SDS-PAGE and Western Blotting:
 - Load equal amounts of protein (20-30 µg) per lane on an SDS-PAGE gel.
 - Transfer the separated proteins to a PVDF membrane.
 - Block the membrane with 5% Bovine Serum Albumin (BSA) in Tris-Buffered Saline with Tween 20 (TBST) for 1 hour at room temperature. Avoid using milk as a blocking agent as it contains phosphoproteins that can cause high background.[\[10\]](#)[\[11\]](#)
 - Incubate the membrane with primary antibodies against phospho-Akt (Ser473), total Akt, phospho-S6, total S6, and a loading control (e.g., GAPDH or β-actin) overnight at 4°C.
 - Wash the membrane with TBST and incubate with the appropriate HRP-conjugated secondary antibody for 1 hour at room temperature.
 - Detect the signal using an enhanced chemiluminescence (ECL) substrate.[\[10\]](#)

Visualizations

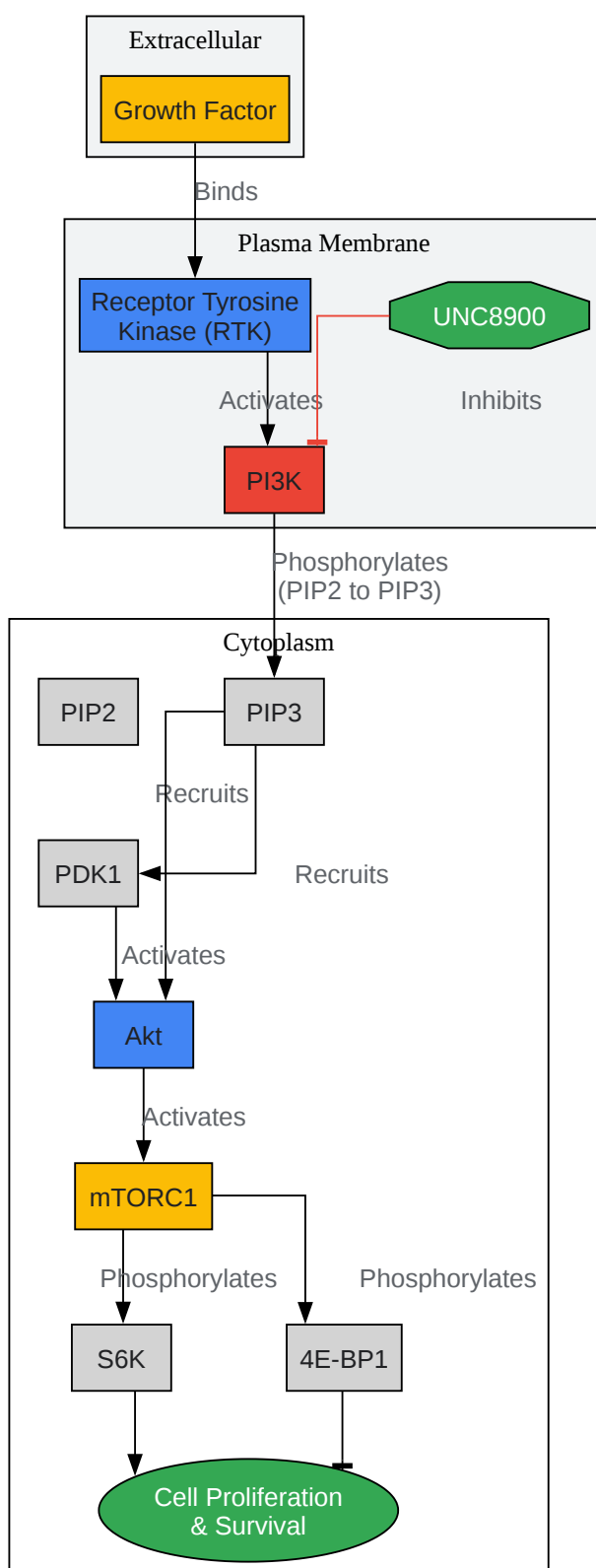

[Click to download full resolution via product page](#)

Caption: **UNC8900** inhibits the PI3K/Akt/mTOR signaling pathway.

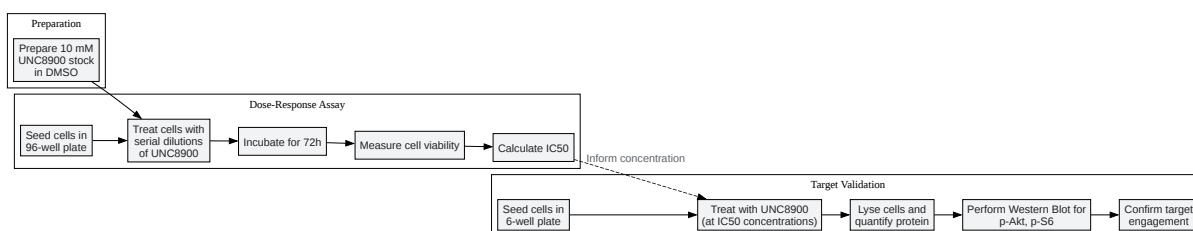

[Click to download full resolution via product page](#)

Caption: Experimental workflow for optimizing **UNC8900** concentration.

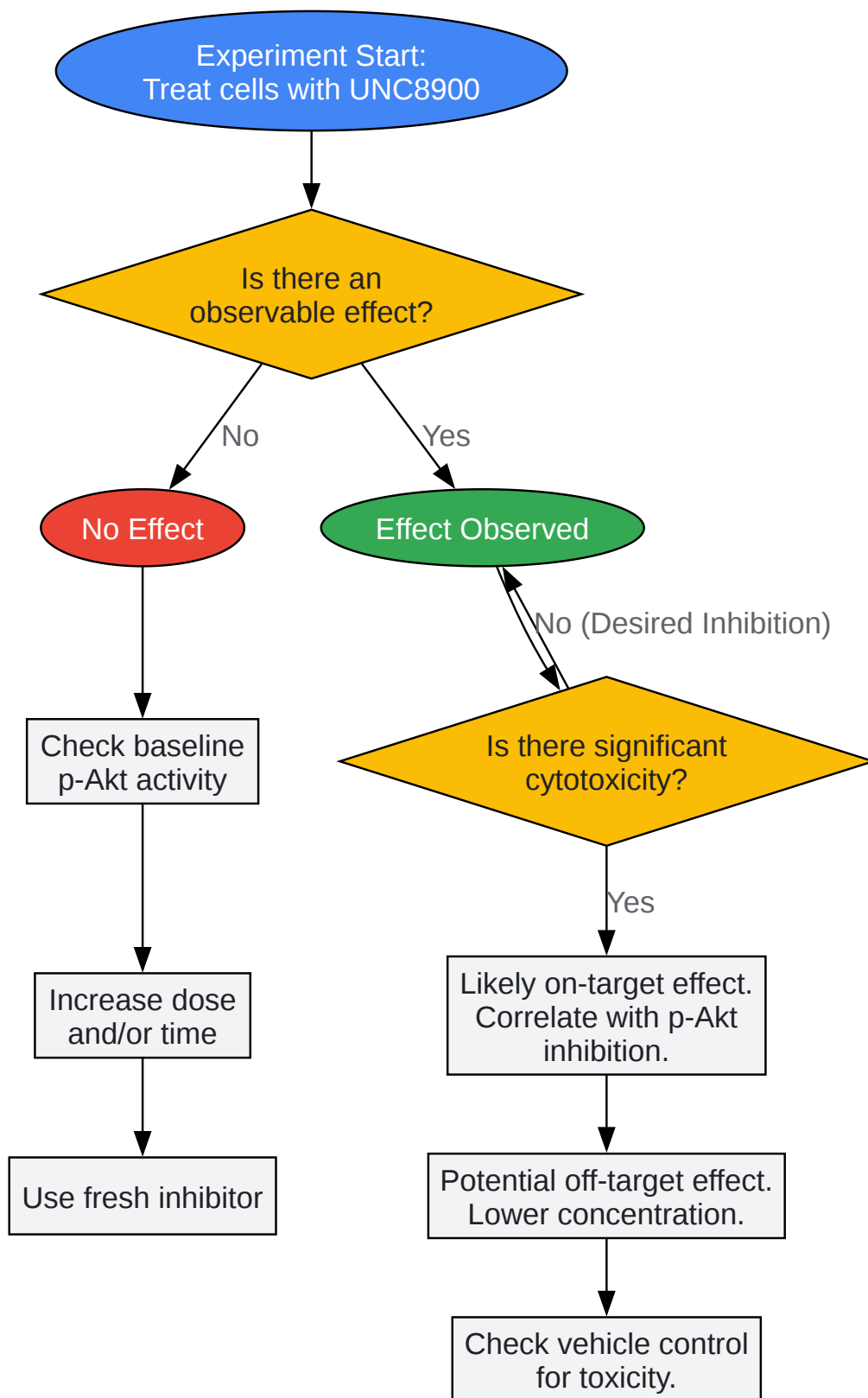

[Click to download full resolution via product page](#)

Caption: Troubleshooting logic for **UNC8900** experiments.

Need Custom Synthesis?

BenchChem offers custom synthesis for rare earth carbides and specific isotopic labeling.

Email: info@benchchem.com or [Request Quote Online](#).

References

- [1. PI3K/AKT/mTOR pathway - Wikipedia \[en.wikipedia.org\]](#)
- [2. Frontiers | PI3K/Akt/mTOR Pathway and Its Role in Cancer Therapeutics: Are We Making Headway? \[frontiersin.org\]](#)
- [3. PI3K/AKT/mTOR Signaling Network in Human Health and Diseases - PMC \[pmc.ncbi.nlm.nih.gov\]](#)
- [4. The PI3K/AKT/mTOR pathway in breast cancer: targets, trials and biomarkers - PMC \[pmc.ncbi.nlm.nih.gov\]](#)
- [5. benchchem.com \[benchchem.com\]](#)
- [6. benchchem.com \[benchchem.com\]](#)
- [7. benchchem.com \[benchchem.com\]](#)
- [8. benchchem.com \[benchchem.com\]](#)
- [9. graphpad.com \[graphpad.com\]](#)
- [10. researchgate.net \[researchgate.net\]](#)
- [11. manuals.plus \[manuals.plus\]](#)
- To cite this document: BenchChem. [Technical Support Center: Optimizing UNC8900 Concentration for Experiments]. BenchChem, [2026]. [Online PDF]. Available at: [<https://www.benchchem.com/product/b12382066/docs#technical-support-center-optimizing-unc8900-concentration-for-experiments>]

Disclaimer & Data Validity:

The information provided in this document is for Research Use Only (RUO) and is strictly not intended for diagnostic or therapeutic procedures. While BenchChem strives to provide accurate protocols, we make no warranties, express or implied, regarding the fitness of this product for every specific experimental setup.

Technical Support: The protocols provided are for reference purposes. Unsure if this reagent suits your experiment?

Need Industrial/Bulk Grade? [Request Custom Synthesis Quote](#)

BenchChem

Our mission is to be the trusted global source of essential and advanced chemicals, empowering scientists and researchers to drive progress in science and industry.

Contact

Address: 3281 E Guasti Rd
Ontario, CA 91761, United States
Phone: (601) 213-4426
Email: info@benchchem.com

[Contact our Ph.D. Support Team for a compatibility check](#)