

Optimizing SDU-071 concentration for experiments

Author: BenchChem Technical Support Team. **Date:** April 2026

Compound of Interest

Compound Name: SDU-071
Cat. No.: B12382603

[Get Quote](#)

Technical Support Center: SDU-071

This technical support center provides troubleshooting guidance and frequently asked questions for researchers and drug development professionals working with **SDU-071**, a novel BRD4-p53 inhibitor.

Frequently Asked Questions (FAQs)

Q1: What is the mechanism of action of **SDU-071**?

A1: **SDU-071** is a novel inhibitor that disrupts the interaction between BRD4 and p53. This disruption leads to the downregulation of key proteins involved in cell proliferation and cycle progression, such as BRD4, c-Myc, CDK4, and CDK6, and the upregulation of the cell cycle inhibitor p21.[1]

Q2: In which cancer cell lines has **SDU-071** been shown to be effective?

A2: **SDU-071** has demonstrated anti-proliferative, anti-migratory, and anti-invasive effects in MDA-MB-231 triple-negative breast cancer cells.[1]

Q3: What are the observed effects of **SDU-071** on the cell cycle?

A3: In MDA-MB-231 cells, treatment with **SDU-071** leads to an increase in the G1 phase population and a reduction in the S and G2/M phase populations, indicating an alteration of cell cycle progression.^[1]

Q4: Does **SDU-071** induce apoptosis?

A4: Yes, studies have shown that **SDU-071** induces apoptosis in MDA-MB-231 cells.^[1]

Troubleshooting Guide

Issue	Possible Cause	Suggested Solution
Low or no observable effect on cell viability	Inadequate concentration of SDU-071.	Perform a dose-response study to determine the optimal concentration for your specific cell line and experimental conditions. Based on published data, concentrations between 2.5 μ M and 10 μ M have been effective in MDA-MB-231 cells.[1]
Poor solubility of SDU-071 in culture medium.	Ensure SDU-071 is completely dissolved in a suitable solvent (e.g., DMSO) before adding it to the cell culture medium. The final solvent concentration in the medium should be kept low (typically <0.1%) to avoid solvent-induced toxicity.	
Cell line is resistant to SDU-071.	Consider using a different cell line or investigating the expression levels of BRD4 and the status of p53 in your current cell line.	
Inconsistent results between experiments	Variability in cell seeding density.	Ensure consistent cell seeding density across all experiments as cell confluency can affect the response to treatment.
Degradation of SDU-071.	Prepare fresh stock solutions of SDU-071 regularly and store them appropriately as recommended by the manufacturer. Avoid repeated freeze-thaw cycles.	

Observed cytotoxicity at low concentrations

Solvent toxicity.

Perform a vehicle control experiment with the same concentration of the solvent (e.g., DMSO) used to dissolve SDU-071 to rule out solvent-induced cytotoxicity.

Cell line is highly sensitive to SDU-071.

Reduce the concentration range in your dose-response experiments to identify a non-toxic, effective concentration.

Data Presentation

Table 1: In Vitro Efficacy of **SDU-071** on MDA-MB-231 Cells

Parameter	Concentration	Result
Cell Proliferation (IC50)	Not explicitly stated, but dose-response curves were generated.	SDU-071 inhibits cell proliferation.
Cell Cycle Progression	2.5, 5, and 10 μ M	Increased G1 phase, reduced S and G2/M phases.
Apoptosis	2.5, 5, and 10 μ M	Induced apoptosis.

Table 2: In Vivo Efficacy of **SDU-071**

Animal Model	Dosage	Effect
Mouse model with MDA-MB-231 tumors	50 mg/kg	Reduced tumor growth.
Reduced protein levels of BRD4, Mucin 5AC, c-Myc, CDK4, and CDK6.		
Upregulated p21 protein levels.		

Experimental Protocols

Cell Proliferation Assay (CCK-8)

- Seed MDA-MB-231 cells in a 96-well plate at a density of 5×10^3 cells/well.
- After 24 hours, treat the cells with varying concentrations of **SDU-071** (e.g., 0, 1, 2.5, 5, 10, 20 μM).
- Incubate the cells for the desired time period (e.g., 48 hours).
- Add 10 μL of CCK-8 solution to each well and incubate for 1-4 hours at 37°C .
- Measure the absorbance at 450 nm using a microplate reader.
- Calculate the cell viability as a percentage of the control (vehicle-treated) cells.

Cell Cycle Analysis (Flow Cytometry)

- Seed MDA-MB-231 cells in 6-well plates.
- Treat the cells with **SDU-071** (e.g., 2.5, 5, and 10 μM) for 24-48 hours.
- Harvest the cells by trypsinization and wash with ice-cold PBS.
- Fix the cells in 70% ethanol overnight at -20°C .

- Wash the cells with PBS and resuspend in a staining solution containing propidium iodide (PI) and RNase A.
- Incubate in the dark for 30 minutes at room temperature.
- Analyze the cell cycle distribution using a flow cytometer.

Visualizations

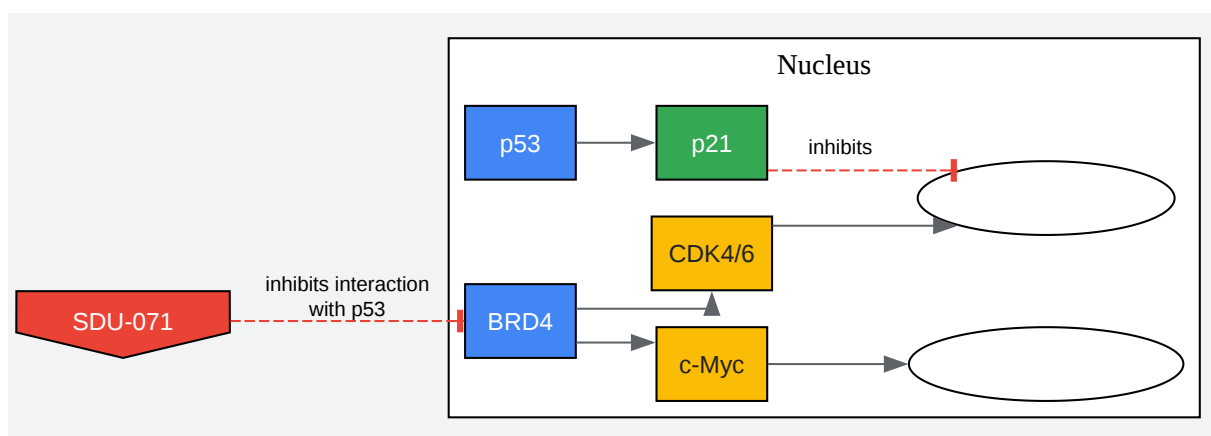

[Click to download full resolution via product page](#)

Caption: **SDU-071** mechanism of action.

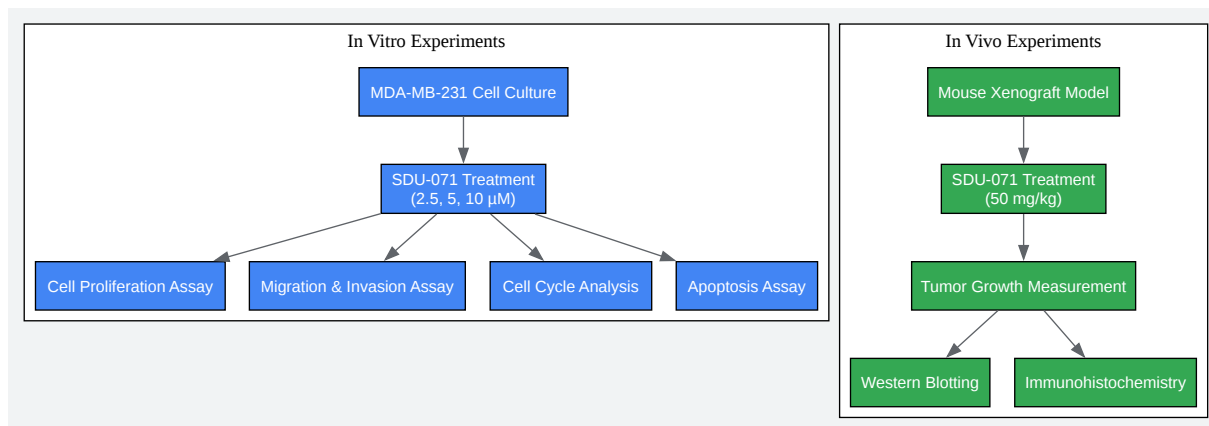

[Click to download full resolution via product page](#)

Caption: Experimental workflow for **SDU-071** evaluation.

Need Custom Synthesis?

BenchChem offers custom synthesis for rare earth carbides and specific isotopic labeling.

Email: info@benchchem.com or [Request Quote Online](#).

References

- 1. Novel BRD4-p53 Inhibitor SDU-071 Suppresses Proliferation and Migration of MDA-MB-231 Triple-Negative Breast Cancer Cells - PMC [pmc.ncbi.nlm.nih.gov]
- To cite this document: BenchChem. [Optimizing SDU-071 concentration for experiments]. BenchChem, [2026]. [Online PDF]. Available at: [https://www.benchchem.com/product/b12382603/docs#optimizing-sdu-071-concentration-for-experiments]

Disclaimer & Data Validity:

The information provided in this document is for Research Use Only (RUO) and is strictly not intended for diagnostic or therapeutic procedures. While BenchChem strives to provide accurate protocols, we make no warranties, express or implied, regarding the fitness of this product for every specific experimental setup.

Technical Support: The protocols provided are for reference purposes. Unsure if this reagent suits your experiment?

Need Industrial/Bulk Grade? [Request Custom Synthesis Quote](#)

BenchChem

Our mission is to be the trusted global source of essential and advanced chemicals, empowering scientists and researchers to drive progress in science and industry.

Contact

Address: 3281 E Guasti Rd
Ontario, CA 91761, United States
Phone: (601) 213-4426
Email: info@benchchem.com

[Contact our Ph.D. Support Team for a compatibility check](#)