

Definitive Guide: Validating E3 Ligase Target Engagement

Author: BenchChem Technical Support Team. **Date:** May 2026

Compound of Interest

Compound Name: *E3 Ligase Ligand-linker Conjugate*
82
Cat. No.: *B12382410*

[Get Quote](#)

Executive Summary

In Targeted Protein Degradation (TPD), the formation of a binary complex between a small molecule (PROTAC or Molecular Glue) and an E3 ubiquitin ligase is the prerequisite for efficacy.^[1] However, biochemical potency often fails to translate to cellular activity due to permeability barriers and intracellular competition.

This guide objectively compares the three dominant validation modalities: NanoBRET™ TE (Cellular Quantitative), CETSA® (Cellular Qualitative/Endogenous), and SPR (Biophysical Kinetic).

The Verdict:

- Use NanoBRET for Rank-Ordering.^{[2][3]} It is the only method that quantifies intracellular affinity () and permeability simultaneously.

- Use CETSA for Physiological Validation.[4] It confirms engagement with the endogenous wild-type protein in disease-relevant cell lines.
- Use SPR for Mechanistic Definition. It provides precise rates essential for modeling ternary complex cooperativity.

Part 1: Comparative Landscape

The "Binary Complex" Challenge

Unlike traditional inhibitors, E3 ligase binders must compete with high concentrations of endogenous substrates and operate within a specific kinetic window to induce ubiquitination.

Methodological Comparison Matrix

Feature	NanoBRET™ TE	CETSA® (Classic/HT)	SPR (Biacore/Octet)
Primary Readout	Energy Transfer (mBU)	Thermal Stability ()	Refractive Index (RU)
System	Live Cells (Transfected)	Live Cells/Lysate (Endogenous)	Purified Protein (In Vitro)
Quantitation	High (, Residence Time)	Medium (shift, isothermal)	High (,)
Throughput	High (384-well)	Medium to High (HT-MS)	Medium
Permeability Insight	Excellent (Live vs. Permeabilized)	Good (Implicit in potency)	None
Key Limitation	Requires fusion vector & tracer	Not all binders induce shift	Lacks cellular context (PTMs)

Part 2: Decision Logic & Workflow

Do not rely on a single assay. A robust TPD pipeline utilizes a cascading validation logic.

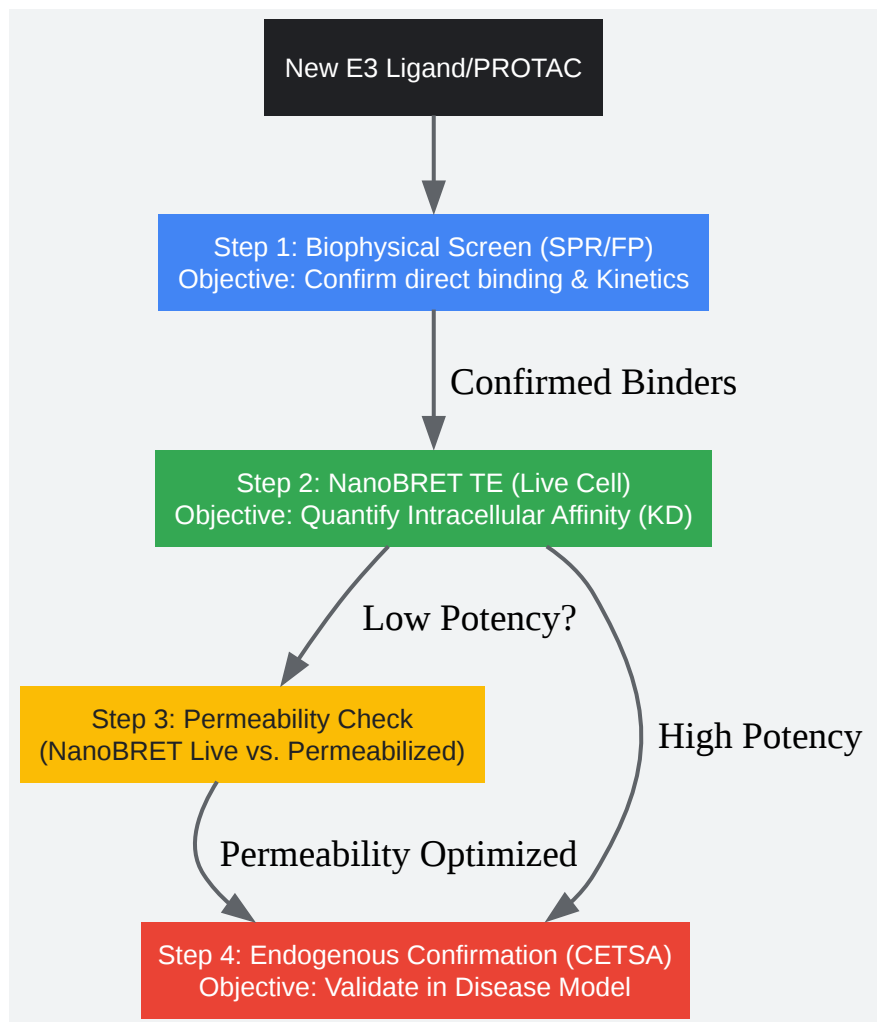

[Click to download full resolution via product page](#)

Figure 1: Strategic workflow for validating E3 ligase engagement. Note the critical "Permeability Check" loop using NanoBRET.

Part 3: Detailed Methodologies

Method A: NanoBRET™ Target Engagement (The Gold Standard)

Why: It is currently the only robust method to distinguish between a compound's affinity for the E3 ligase and its ability to cross the cell membrane.

Mechanism: Energy transfer occurs between a NanoLuc®-fused E3 ligase (Donor) and a cell-permeable fluorescent Tracer (Acceptor).[5] A test compound competes with the Tracer, causing a loss of BRET signal.

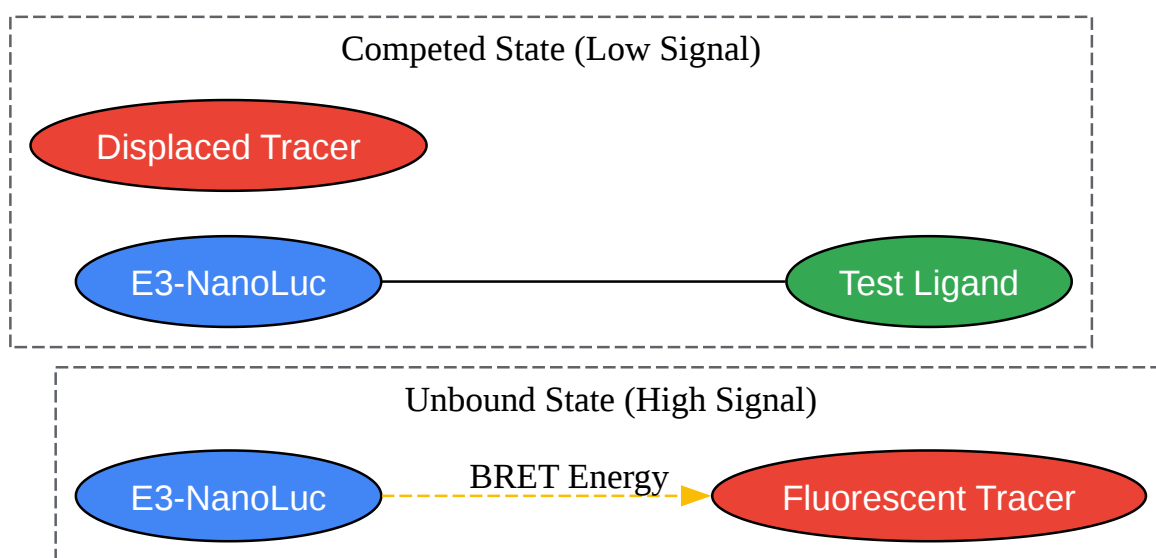

[Click to download full resolution via product page](#)

Figure 2: Competitive displacement mechanism. Test ligands displace the tracer, reducing the BRET ratio.

Protocol: Intracellular E3 Affinity

Reagents: HEK293 Cells, NanoLuc®-CRBN (or VHL) Vector, Cell-Permeable Tracer, Nano-Glo® Substrate.

- Transfection (Day 1):
 - Plate HEK293 cells at 200,000 cells/mL.
 - Transfect with NanoLuc-E3 fusion vector using FuGENE® HD (Ratio 1:3).

- Expert Tip: Co-transfect with carrier DNA (e.g., pGEM-3Z) to optimize expression levels; too much Luciferase saturates the detector.
- Tracer Equilibration (Day 2):
 - Trypsinize and resuspend cells in Opti-MEM (phenol red-free).
 - Add the Tracer at a concentration equal to its (previously determined, typically 0.1–1.0 M).
 - Critical: Do not wash cells. This is a homogeneous assay.
- Compound Treatment:
 - Add serially diluted test compounds (PROTACs).
 - Incubate for 2 hours at 37°C.
- Readout:
 - Add Nano-Glo® Substrate/Inhibitor solution.[6]
 - Measure Donor (460nm) and Acceptor (618nm) emission on a BRET-compatible plate reader (e.g., BMG PHERAstar).
- Data Analysis:
 - Calculate BRET Ratio:
.
 - Fit to limits (0% = No Compound, 100% = No Tracer) to determine
.
 - Convert to Affinity (

) using the Cheng-Prusoff equation adapted for BRET:

Method B: CETSA® (Cellular Thermal Shift Assay)

Why: Confirms the ligand engages the endogenous protein in its native complex, without overexpression artifacts.

Protocol: The "Melt Curve" Validation

Reagents: Target cells (e.g., Jurkat or MM.1S for CRBN), PCR thermal cycler, Lysis Buffer.

- Treatment:
 - Treat live cells with the E3 ligand (at approx 5x [\[7\]](#)[\[8\]](#)) for 1 hour. Include a DMSO control.[\[7\]](#)[\[8\]](#)
- Thermal Challenge:
 - Aliquot cells into PCR tubes.
 - Apply a temperature gradient (e.g., 40°C to 70°C) for 3 minutes.
 - Expert Tip: E3 ligases like CRBN are thermally unstable. Ensure the gradient covers the lower range (42–55°C) thoroughly.
- Lysis & Separation:
 - Cool samples to RT. Lyse using freeze-thaw (3x) or mild detergent (0.4% NP-40).
 - Centrifuge at 20,000 x g for 20 mins at 4°C to pellet precipitated (denatured) proteins.
- Detection:
 - Collect supernatant (soluble fraction).
 - Analyze via Western Blot using a specific anti-E3 antibody.
- Analysis:

- Plot band intensity vs. Temperature.
- Calculate
(Melting Temperature).^{[4][7]} A positive shift (C) indicates binding.

Part 4: Data Interpretation & Troubleshooting

Comparative Data Output

Below is a representation of how data should be structured for internal reports.

Compound	NanoBRET (Live)	NanoBRET (Permeabilized)	Permeability Index	CETSA	Conclusion
Ligand A	50 nM	45 nM	~1.0 (High)	+4.5°C	Lead Candidate
Ligand B	>10 M	30 nM	>300 (Poor)	+0.5°C	Permeability Issue
Ligand C	>10 M	>10 M	N/A	0°C	Non-binder

Self-Validating Controls

- The "VHL-Null" or "CRBN-KO" Control: In CETSA, specificity is proven if the signal disappears in Knock-Out lines.
- The "Impermeable" Tracer: In NanoBRET, comparing Live vs. Permeabilized (Digitonin-treated) cells validates if a lack of potency is due to the cell membrane. If the compound binds in permeabilized cells but not live cells, your chemistry needs permeability optimization, not affinity optimization.

References

- Riching, K. M., et al. (2018). Quantitative Live-Cell Kinetic Analysis of Target Engagement.[9] Chemical Biology & Drug Design. [\[Link\]](#)
- Jafari, R., et al. (2014). The cellular thermal shift assay for evaluating drug target interactions in cells.[4][10][11] Nature Protocols. [\[Link\]](#)
- Testa, A., et al. (2020). Microplate-based CETSA for target engagement of PROTACs. Methods in Molecular Biology. [\[Link\]](#)
- Huber, K. V. M., et al. (2015). Proteome-wide drug target profiling in cells using CETSA-MS. Nature Methods. [\[Link\]](#)

Need Custom Synthesis?

BenchChem offers custom synthesis for rare earth carbides and specific isotopic labeling.

Email: info@benchchem.com or [Request Quote Online](#).

Sources

- 1. [mdpi.com](https://www.mdpi.com) [[mdpi.com](https://www.mdpi.com)]
- 2. A High-Throughput Method to Prioritize PROTAC Intracellular Target Engagement and Cell Permeability Using NanoBRET | Springer Nature Experiments [experiments.springernature.com]
- 3. A High-Throughput Method to Prioritize PROTAC Intracellular Target Engagement and Cell Permeability Using NanoBRET - PubMed [pubmed.ncbi.nlm.nih.gov]
- 4. DARTS vs CETSA: Choosing the Right Assay for Target Validation - Creative Proteomics [[creative-proteomics.com](https://www.creative-proteomics.com)]
- 5. NanoBRET® TE E3 Ligase Vectors | CRBN | VHL | DDB1 [[promega.jp](https://www.promega.jp)]
- 6. [promega.com](https://www.promega.com) [[promega.com](https://www.promega.com)]
- 7. [wuxibiology.com](https://www.wuxibiology.com) [[wuxibiology.com](https://www.wuxibiology.com)]
- 8. [biorxiv.org](https://www.biorxiv.org) [[biorxiv.org](https://www.biorxiv.org)]
- 9. NanoBRET® Target Engagement | Live-Cell Compound Binding Assay [[promega.kr](https://www.promega.kr)]

- [10. pelagobio.com \[pelagobio.com\]](https://pelagobio.com)
- [11. A Shift in Thinking: Cellular Thermal Shift Assay-Enabled Drug Discovery - PMC \[pmc.ncbi.nlm.nih.gov\]](https://pubmed.ncbi.nlm.nih.gov/36111111/)
- To cite this document: BenchChem. [Definitive Guide: Validating E3 Ligase Target Engagement]. BenchChem, [2026]. [Online PDF]. Available at: [\[https://www.benchchem.com/product/b12382410/docs#definitive-guide-validating-e3-ligase-target-engagement\]](https://www.benchchem.com/product/b12382410/docs#definitive-guide-validating-e3-ligase-target-engagement)

Disclaimer & Data Validity:

The information provided in this document is for Research Use Only (RUO) and is strictly not intended for diagnostic or therapeutic procedures. While BenchChem strives to provide accurate protocols, we make no warranties, express or implied, regarding the fitness of this product for every specific experimental setup.

Technical Support: The protocols provided are for reference purposes. Unsure if this reagent suits your experiment?

Need Industrial/Bulk Grade? [Request Custom Synthesis Quote](#)

BenchChem

Our mission is to be the trusted global source of essential and advanced chemicals, empowering scientists and researchers to drive progress in science and industry.

Contact

Address: 3281 E Guasti Rd
Ontario, CA 91761, United States
Phone: (601) 213-4426
Email: info@benchchem.com

[Contact our Ph.D. Support Team for a compatibility check](#)

