

An In-depth Technical Guide to the Structure and Synthesis of BMS-986365

Author: BenchChem Technical Support Team. **Date:** April 2026

Compound of Interest

Compound Name: BMS-986365

Cat. No.: B12382607

[Get Quote](#)

For Researchers, Scientists, and Drug Development Professionals

Introduction

BMS-986365, also known as Gridegalutamide, is a pioneering, orally bioavailable, heterobifunctional molecule currently under investigation for the treatment of metastatic castration-resistant prostate cancer (mCRPC).[1][2] Developed by Bristol Myers Squibb, this compound represents a significant advancement in the field of targeted protein degradation. It functions as a potent and selective androgen receptor (AR) antagonist and, uniquely, as a ligand-directed degrader (LDD). This dual mechanism of action allows **BMS-986365** to not only block the AR signaling pathway but also to induce the degradation of the AR protein itself, offering a promising new therapeutic strategy for cancers driven by androgen receptor activity. [1][3]

This technical guide provides a comprehensive overview of the structure, physicochemical properties, and synthesis of **BMS-986365**, intended for professionals in the fields of medicinal chemistry, pharmacology, and drug development.

Chemical Structure and Properties

BMS-986365 is a complex molecule comprised of three key components: a ligand that binds to the androgen receptor, a linker, and a ligand that recruits the Cereblon (CRBN) E3 ubiquitin ligase. This tripartite structure is the hallmark of a Proteolysis Targeting Chimera (PROTAC).

IUPAC Name: 2-[(2R)-4-[2-[4-[3-[4-cyano-3-(trifluoromethyl)phenyl]-5,5-dimethyl-4-oxo-2-sulfanylideneimidazolidin-1-yl]-2-ethylphenoxy]ethyl]-2-methylpiperazin-1-yl]-N-[3-[[[(3R)-2,6-dioxopiperidin-3-yl]amino]phenyl]acetamide[4]

Chemical Formula: $C_{41}H_{45}F_3N_8O_5S$ [4]

Molecular Weight: 818.92 g/mol [4]

Physicochemical Properties

Property	Value	Source
CAS Number	2446929-86-6	[4]
Appearance	Solid	[5]
Solubility	Soluble in DMSO	[6]

Synthesis of BMS-986365

The synthesis of **BMS-986365** is a multi-step process that involves the careful assembly of its three core components. The synthetic route has been described in the patent literature, specifically in patent WO2020132014A1 (example 17), and is also referenced in the supplementary information of a key publication on its discovery.[7][8]

While detailed, step-by-step experimental protocols with specific reagent quantities and reaction conditions are proprietary and not fully disclosed in the public domain, the overall synthetic strategy can be outlined as follows. The synthesis involves the preparation of three key intermediates which are then coupled to form the final molecule.

Overall Synthetic Workflow

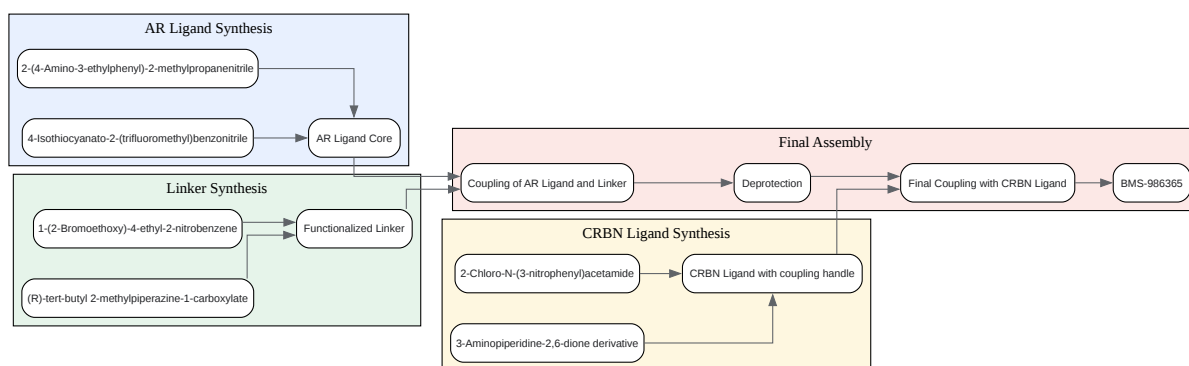

[Click to download full resolution via product page](#)

Caption: High-level synthetic workflow for **BMS-986365**.

Mechanism of Action: Dual-Action AR Inhibition and Degradation

BMS-986365 exhibits a novel, dual mechanism of action that distinguishes it from traditional androgen receptor antagonists.^{[1][3]}

- **Competitive Antagonism:** The AR-binding moiety of **BMS-986365** competitively binds to the ligand-binding domain (LBD) of the androgen receptor. This direct inhibition blocks the binding of endogenous androgens, thereby preventing the conformational changes required for AR activation and downstream signaling.

- Targeted Protein Degradation: The second, and perhaps more critical, mode of action is the targeted degradation of the AR protein. The cereblon-binding moiety of **BMS-986365** recruits the CRBN E3 ubiquitin ligase complex. This proximity induces the ubiquitination of the androgen receptor, marking it for degradation by the proteasome. This degradation of the AR protein itself, rather than just its inhibition, leads to a more profound and sustained suppression of AR signaling.[3]

Signaling Pathway Diagram

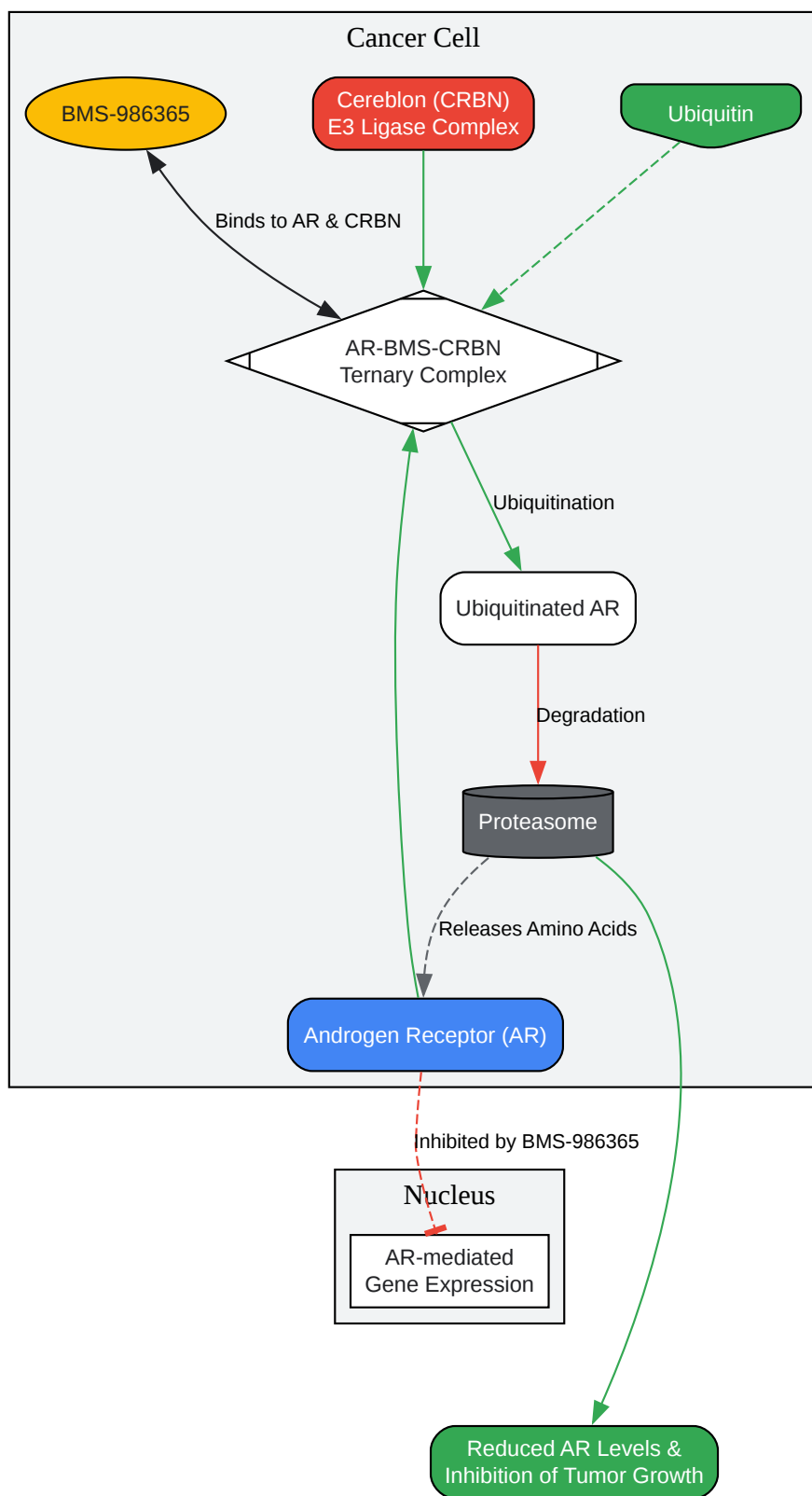

[Click to download full resolution via product page](#)

Caption: Mechanism of action of **BMS-986365**.

Experimental Protocols

As the detailed experimental protocols for the synthesis of **BMS-986365** are proprietary, this section provides a generalized methodology based on the available literature. Researchers attempting to synthesize this molecule should refer to the specific procedures outlined in patent WO2020132014A1.

General Experimental Considerations:

- **Inert Atmosphere:** All reactions should be carried out under an inert atmosphere, such as nitrogen or argon, to prevent the degradation of sensitive reagents and intermediates.
- **Anhydrous Solvents:** Anhydrous solvents should be used for all reactions, as the presence of water can interfere with many of the coupling reactions.
- **Chromatographic Purification:** Purification of intermediates and the final product is typically achieved using column chromatography on silica gel. The choice of eluent will depend on the polarity of the compound being purified.
- **Analytical Characterization:** The identity and purity of all synthesized compounds should be confirmed by analytical techniques such as Nuclear Magnetic Resonance (NMR) spectroscopy (^1H and ^{13}C), Mass Spectrometry (MS), and High-Performance Liquid Chromatography (HPLC).

Conclusion

BMS-986365 represents a promising new therapeutic agent for the treatment of metastatic castration-resistant prostate cancer. Its innovative dual mechanism of action, combining competitive antagonism with targeted degradation of the androgen receptor, offers the potential for a more profound and durable response compared to existing therapies. The synthesis of this complex molecule is a challenging but achievable endeavor for those with expertise in multi-step organic synthesis. This guide provides a foundational understanding of the structure, synthesis, and mechanism of action of **BMS-986365** to aid researchers and drug development professionals in their efforts to advance the field of targeted protein degradation and develop new treatments for cancer.

Need Custom Synthesis?

BenchChem offers custom synthesis for rare earth carbides and specific isotopic labeling.

Email: info@benchchem.com or [Request Quote Online](#).

References

- [1. aacrjournals.org \[aacrjournals.org\]](https://aacrjournals.org)
- [2. urotoday.com \[urotoday.com\]](https://urotoday.com)
- [3. About BMS-986365 | BMS Clinical Trials \[bmsclinicaltrials.com\]](https://bmsclinicaltrials.com)
- [4. researchgate.net \[researchgate.net\]](https://researchgate.net)
- [5. US20150157656A1 - Method for Treatment of Castration-Resistant Prostate Cancer - Google Patents \[patents.google.com\]](#)
- [6. aacrjournals.org \[aacrjournals.org\]](https://aacrjournals.org)
- [7. championsoncology.com \[championsoncology.com\]](https://championsoncology.com)
- [8. Discovery of BMS-986365, a first-in-class dual androgen receptor ligand-directed degrader \(AR LDD\) and antagonist, for the treatment of advanced prostate cancer - PubMed \[pubmed.ncbi.nlm.nih.gov\]](#)
- To cite this document: BenchChem. [An In-depth Technical Guide to the Structure and Synthesis of BMS-986365]. BenchChem, [2026]. [Online PDF]. Available at: [\[https://www.benchchem.com/product/b12382607/docs#an-in-depth-technical-guide-to-the-structure-and-synthesis-of-bms-986365\]](https://www.benchchem.com/product/b12382607/docs#an-in-depth-technical-guide-to-the-structure-and-synthesis-of-bms-986365)

Disclaimer & Data Validity:

The information provided in this document is for Research Use Only (RUO) and is strictly not intended for diagnostic or therapeutic procedures. While BenchChem strives to provide accurate protocols, we make no warranties, express or implied, regarding the fitness of this product for every specific experimental setup.

Technical Support: The protocols provided are for reference purposes. Unsure if this reagent suits your experiment?

Need Industrial/Bulk Grade? [Request Custom Synthesis Quote](#)

BenchChem

Our mission is to be the trusted global source of essential and advanced chemicals, empowering scientists and researchers to drive progress in science and industry.

Contact

Address: 3281 E Guasti Rd

Ontario, CA 91761, United States

Phone: (601) 213-4426

Email: info@benchchem.com

[Contact our Ph.D. Support Team for a compatibility check](#)