

Troubleshooting inconsistent results in BMS-332 experiments

Author: BenchChem Technical Support Team. **Date:** April 2026

Compound of Interest

Compound Name: BMS-332

Cat. No.: B12381880

[Get Quote](#)

Technical Support Center: BMS-332 Experiments

This technical support center provides troubleshooting guidance and frequently asked questions (FAQs) for researchers using **BMS-332**, a dual inhibitor of diacylglycerol kinase alpha (DGK α) and diacylglycerol kinase zeta (DGK ζ), in experimental settings.

Frequently Asked Questions (FAQs)

Q1: What is **BMS-332** and what is its primary mechanism of action?

BMS-332 is a potent and selective small molecule inhibitor of the lipid kinases DGK α and DGK ζ .^{[1][2]} In the context of immunology, T-cell receptor (TCR) engagement leads to the production of the second messenger diacylglycerol (DAG). DGK α and DGK ζ negatively regulate T-cell signaling by converting DAG to phosphatidic acid (PA), thereby dampening the immune response. By inhibiting DGK α and DGK ζ , **BMS-332** sustains DAG signaling, which enhances T-cell activation, cytokine production, and anti-tumor immunity. This mechanism makes it a candidate for combination therapies with immune checkpoint inhibitors like anti-PD-1.

Q2: What are the recommended solvent and storage conditions for **BMS-332**?

For in vitro experiments, **BMS-332** can be dissolved in DMSO to prepare a stock solution.[1] One supplier suggests a solubility of up to 14.29 mg/mL in DMSO with ultrasonic assistance and warming to 60°C.[1] It is crucial to store the stock solution in aliquots to avoid repeated freeze-thaw cycles. Recommended storage is at -20°C for up to one month or at -80°C for up to six months.[3]

Q3: I am not observing the expected enhancement of T-cell activation with **BMS-332**. What are the possible reasons?

Several factors could contribute to a lack of effect. Please consider the following:

- **Suboptimal T-cell Stimulation:** **BMS-332** is most effective when T-cell receptor signaling is present but suboptimal.[4] If the initial T-cell stimulation (e.g., with anti-CD3/CD28 beads or antigen-presenting cells) is too strong, the potentiating effect of **BMS-332** may be masked. Conversely, if the stimulation is too weak or absent, there will be no signaling cascade for **BMS-332** to amplify.
- **Incorrect Compound Concentration:** Ensure that the final concentration of **BMS-332** in your assay is appropriate. An effective concentration range should be determined by a dose-response experiment.
- **Cell Viability:** Poor cell viability of your primary T-cells or co-cultured cells can significantly impact results. Always check cell viability before and after the experiment.
- **Assay Timing:** The timing of **BMS-332** addition relative to T-cell stimulation is critical. Ensure the inhibitor is present during the activation phase.

Q4: My T-cell proliferation assay shows inconsistent results between replicates. What can I do to improve reproducibility?

Inconsistent results in T-cell proliferation assays are a common issue. Here are some troubleshooting steps:

- **Consistent Cell Seeding:** Ensure accurate and consistent cell counts and seeding densities across all wells.

- **Homogeneous Compound Distribution:** After adding **BMS-332**, mix the plate gently to ensure even distribution of the compound in the media.
- **Plate Edge Effects:** Avoid using the outer wells of 96-well plates, as they are more prone to evaporation, which can alter compound and media concentrations.
- **Standardized Stimulation:** If using antigen-presenting cells, ensure a consistent ratio of effector to target cells. If using beads, ensure they are well-resuspended before addition to the wells.
- **Incubation Conditions:** Maintain consistent temperature and CO₂ levels in the incubator.

Troubleshooting Guide

Issue	Possible Cause	Recommended Solution
Low Potency / No Effect	Inactive compound due to improper storage.	Aliquot stock solutions and avoid repeated freeze-thaw cycles. Store at -80°C for long-term storage.[3]
Suboptimal T-cell stimulation.	Titrate the concentration of your stimulating agent (e.g., anti-CD3/CD28 or peptide antigen). The effect of BMS-332 is more pronounced with suboptimal TCR signaling.[4]	
Incorrect timing of compound addition.	Add BMS-332 concurrently with or shortly before T-cell stimulation to ensure it is active during the signaling cascade.	
High Background Signal in Control Wells	DMSO concentration is too high.	Ensure the final DMSO concentration in all wells (including vehicle controls) is consistent and ideally below 0.5%.
Contamination of cell cultures.	Regularly test cell lines for mycoplasma contamination. Use aseptic techniques during all experimental procedures.	
Inconsistent Results Between Experiments	Lot-to-lot variability of reagents.	If possible, use the same lot of critical reagents (e.g., FBS, cytokines, antibodies) for a set of experiments. Qualify new lots of reagents before use in critical studies.
Donor variability in primary T-cells.	When using primary human T-cells, be aware of donor-to-donor variability. If possible,	

perform experiments with cells from multiple donors to ensure the observed effects are not donor-specific.

Unexpected Cell Toxicity

Compound precipitation at high concentrations.

Visually inspect the media for any signs of precipitation after adding BMS-332. If precipitation occurs, reconsider the stock concentration and final dilution.

Off-target effects.

While BMS-332 is selective for DGK α and DGK ζ , high concentrations may lead to off-target effects. Perform a dose-response curve to identify the optimal concentration with minimal toxicity.

Data Summary

BMS-332 Potency and Selectivity

Target	IC50 (nM)	Assay Type
DGK α	5	YFP-DGK α translocation assay[3]
DGK ζ	1	YFP-DGK ζ translocation assay[3]
DGK β	>100-fold selectivity vs DGK α	Biochemical assay
DGK γ	>100-fold selectivity vs DGK α	Biochemical assay

Experimental Conditions for BMS-332

Parameter	Condition	Notes
Stock Solution	10-20 mM in DMSO	Store at -80°C in single-use aliquots.[1][3]
In Vitro Working Concentration	10 nM - 1 μM	Optimal concentration is assay-dependent and should be determined empirically.
Cell Types	Primary human or mouse T-cells, Jurkat T-cells	The effects will be most pronounced in cells expressing DGKα and DGKζ.
Typical Assays	T-cell proliferation, cytokine release (IFN-γ, IL-2), cytotoxicity assays	Can be used in co-culture with antigen-presenting cells or tumor cells.

Experimental Protocols & Visualizations

DGKα/ζ Signaling Pathway in T-Cells

The following diagram illustrates the central role of DGKα and DGKζ in T-cell activation and the mechanism of action for **BMS-332**.

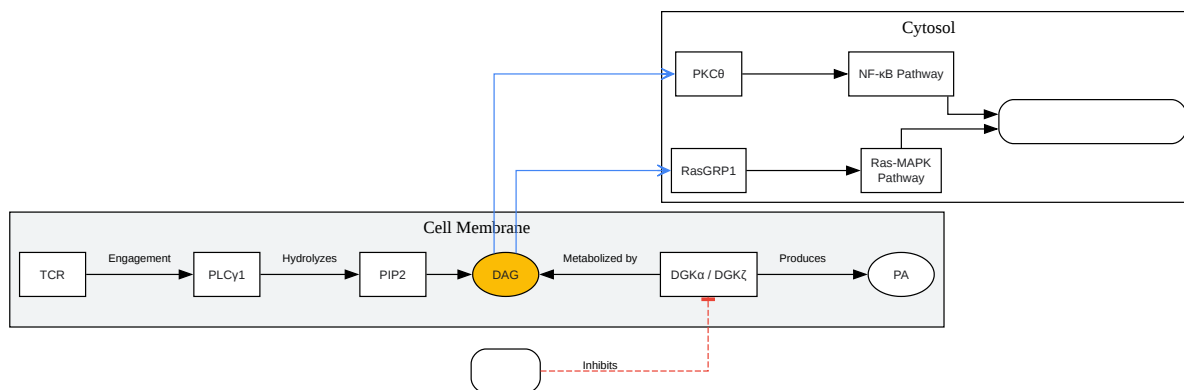

[Click to download full resolution via product page](#)

Caption: DGKα/ζ signaling pathway in T-cells and the inhibitory action of **BMS-332**.

Experimental Workflow for T-Cell Co-Culture Assay

This diagram outlines a typical workflow for assessing the effect of **BMS-332** on T-cell activation in a co-culture system with tumor cells.

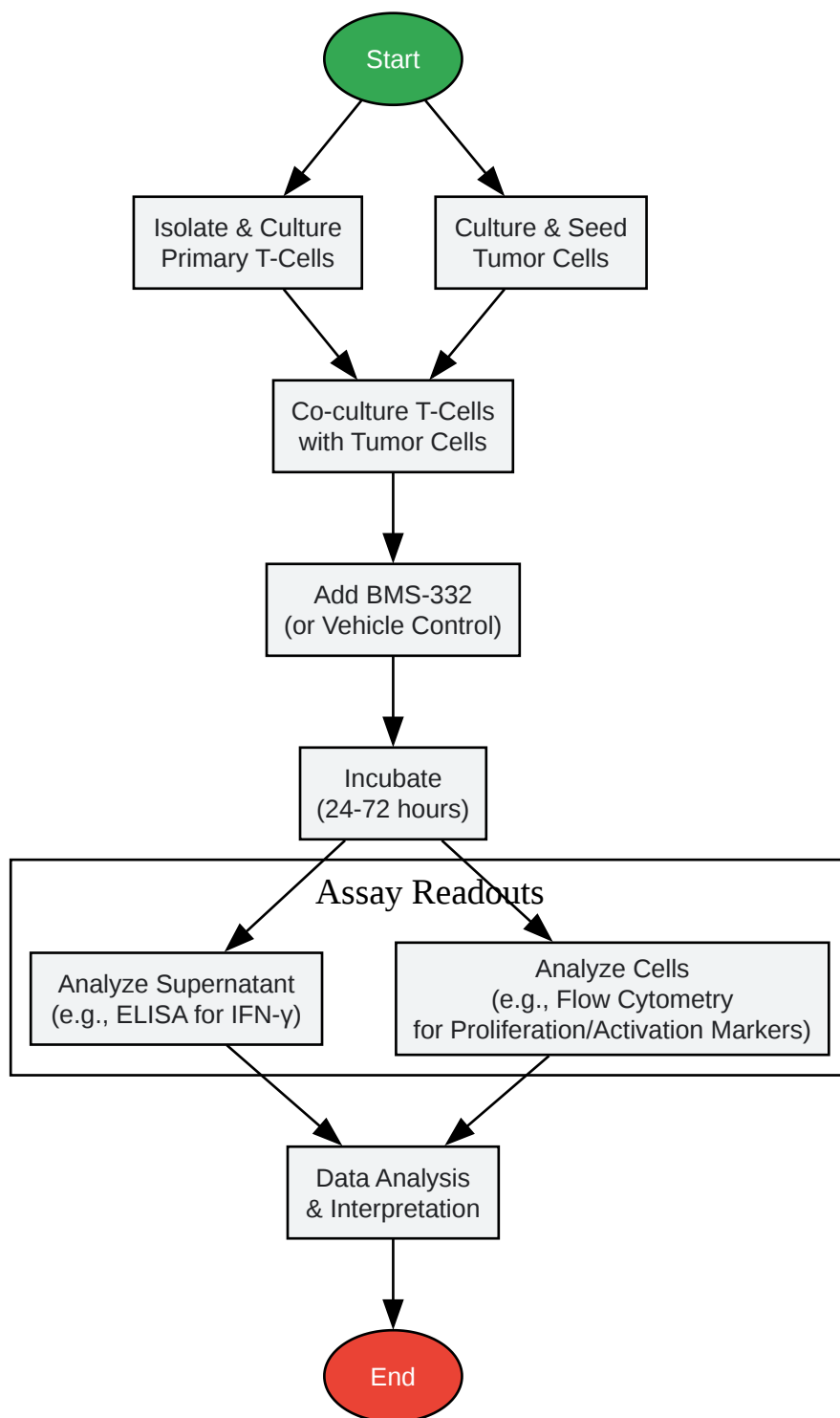

[Click to download full resolution via product page](#)

Caption: A generalized experimental workflow for a T-cell and tumor cell co-culture assay.

Troubleshooting Logic for Inconsistent Results

This decision tree provides a logical approach to troubleshooting inconsistent experimental outcomes.

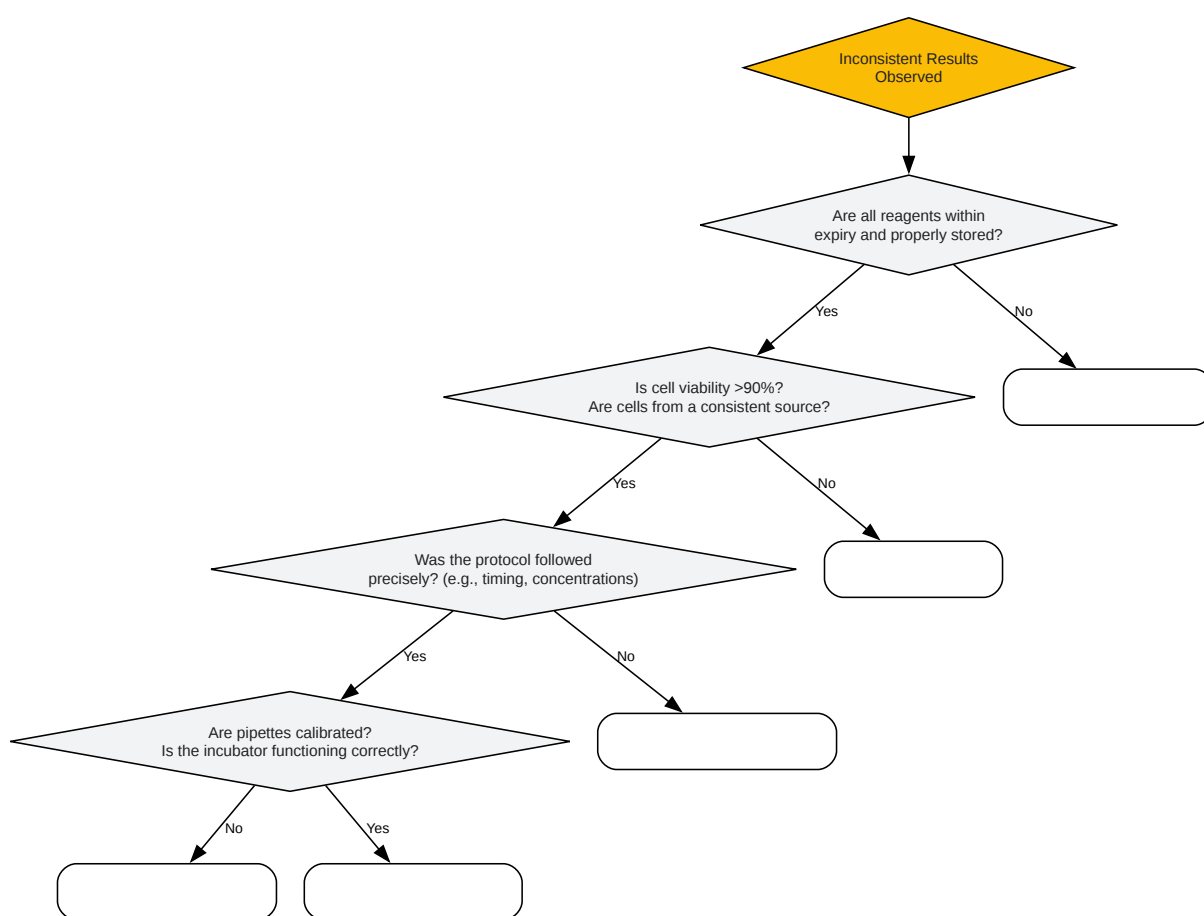

[Click to download full resolution via product page](#)

Caption: A decision tree for troubleshooting inconsistent experimental results.

Need Custom Synthesis?

BenchChem offers custom synthesis for rare earth carbides and specific isotopic labeling.

Email: info@benchchem.com or [Request Quote Online](#).

References

- [1. glpbio.com \[glpbio.com\]](http://glpbio.com)
- [2. Diacylglycerol Kinase \(DGK\) \(inhibitors, antagonists, agonists\)-ProbeChem.com \[probechem.com\]](http://probechem.com)
- [3. medchemexpress.com \[medchemexpress.com\]](http://medchemexpress.com)
- [4. DGK \$\alpha/\zeta\$ inhibition lowers the TCR affinity threshold and potentiates antitumor immunity - PMC \[pmc.ncbi.nlm.nih.gov\]](https://pubmed.ncbi.nlm.nih.gov/)
- To cite this document: BenchChem. [Troubleshooting inconsistent results in BMS-332 experiments]. BenchChem, [2026]. [Online PDF]. Available at: [\[https://www.benchchem.com/product/b12381880/docs#troubleshooting-inconsistent-results-in-bms-332-experiments\]](https://www.benchchem.com/product/b12381880/docs#troubleshooting-inconsistent-results-in-bms-332-experiments)

Disclaimer & Data Validity:

The information provided in this document is for Research Use Only (RUO) and is strictly not intended for diagnostic or therapeutic procedures. While BenchChem strives to provide accurate protocols, we make no warranties, express or implied, regarding the fitness of this product for every specific experimental setup.

Technical Support: The protocols provided are for reference purposes. Unsure if this reagent suits your experiment?

Need Industrial/Bulk Grade? [Request Custom Synthesis Quote](#)

BenchChem

Our mission is to be the trusted global source of essential and advanced chemicals, empowering scientists and researchers to drive progress in science and industry.

Contact

Address: 3281 E Guasti Rd

Ontario, CA 91761, United States

Phone: (601) 213-4426

Email: info@benchchem.com

[Contact our Ph.D. Support Team for a compatibility check](#)