

Technical Support Center: Brivanib Recovery from Biological Samples

Author: BenchChem Technical Support Team. **Date:** April 2026

Compound of Interest

Compound Name: (R)-Brivanib alaninate-d4

Cat. No.: B12381546

[Get Quote](#)

This technical support center provides researchers, scientists, and drug development professionals with comprehensive troubleshooting guides and frequently asked questions (FAQs) to improve the recovery of Brivanib from biological samples.

I. Frequently Asked Questions (FAQs)

Q1: What are the most common methods for extracting Brivanib from biological samples?

A1: The most commonly employed methods for extracting Brivanib and other tyrosine kinase inhibitors (TKIs) from biological matrices are Protein Precipitation (PPT), Liquid-Liquid Extraction (LLE), and Solid-Phase Extraction (SPE).[1][2] The choice of method depends on the biological matrix, the required level of cleanliness of the extract, and the desired analytical sensitivity.

Q2: Which analytical technique is typically used for the quantification of Brivanib in biological samples?

A2: Liquid chromatography-tandem mass spectrometry (LC-MS/MS) is the standard analytical technique for the quantification of Brivanib.[3] This method offers high sensitivity and selectivity, which is crucial for accurately measuring drug concentrations in complex biological matrices.

Q3: Why is an internal standard important in Brivanib bioanalysis?

A3: An internal standard (IS) is essential for accurate and precise quantification in LC-MS/MS analysis. It is added at a known concentration to all samples, calibrators, and quality controls to correct for variability in sample preparation, injection volume, and instrument response.[4] For Brivanib, a stable isotope-labeled (SIL) internal standard, such as $[^{13}\text{C}_3,^{15}\text{N}_2]\text{BMS-540215}$, is considered the gold standard as it mimics the analyte's behavior most closely.[3]

Q4: What is the "matrix effect" and how can it affect Brivanib analysis?

A4: The matrix effect is the alteration of an analyte's ionization efficiency by co-eluting endogenous components of the biological sample.[5] This can lead to ion suppression or enhancement, resulting in inaccurate quantification of Brivanib.[4][5] Strategies to mitigate matrix effects include efficient sample cleanup, optimization of chromatographic conditions to separate Brivanib from interfering components, and the use of a suitable internal standard.[6][7][8]

Q5: How should biological samples for Brivanib analysis be stored to ensure stability?

A5: Proper storage is critical to prevent the degradation of Brivanib in biological samples. While specific stability data for Brivanib is not extensively published, general guidelines for small molecule drugs suggest storing plasma, serum, and urine samples at -70°C or lower for long-term stability.[9][10] Repeated freeze-thaw cycles should be avoided as they can lead to degradation.[9] It is crucial to perform stability studies under the specific storage and handling conditions of your laboratory.[10]

II. Troubleshooting Guides

This section provides solutions to common problems encountered during the extraction and analysis of Brivanib.

Troubleshooting Low Recovery

Observed Problem	Potential Causes	Recommended Solutions
Low recovery after Protein Precipitation (PPT)	Incomplete protein precipitation due to insufficient solvent volume or inadequate mixing. Analyte co-precipitation with proteins.	Increase the ratio of organic solvent (e.g., acetonitrile, methanol) to sample volume (typically 3:1 or 4:1). Ensure vigorous vortexing for at least 1 minute to facilitate complete protein denaturation. Optimize the precipitation solvent; for some analytes, a combination of solvents may be more effective. [11] [12] [13]
Low recovery after Liquid-Liquid Extraction (LLE)	Inappropriate extraction solvent polarity. Suboptimal pH of the aqueous phase. Insufficient mixing or phase separation.	Screen different organic solvents with varying polarities (e.g., ethyl acetate, methyl tert-butyl ether) to find the optimal one for Brivanib. Adjust the pH of the sample to ensure Brivanib is in its neutral form for efficient extraction into the organic phase. Increase vortexing time and ensure complete phase separation by adequate centrifugation.
Low recovery after Solid-Phase Extraction (SPE)	Inappropriate sorbent selection. Incorrect pH during sample loading. Inefficient elution of the analyte. Sample breakthrough during loading.	Select an SPE sorbent based on the physicochemical properties of Brivanib (e.g., reversed-phase C18 or a mixed-mode cation exchange sorbent). [14] Adjust the pH of the sample to ensure optimal retention on the sorbent. Test different elution solvents and volumes to ensure complete elution of Brivanib from the cartridge. Slow down the

sample loading flow rate to allow for sufficient interaction between Brivanib and the sorbent.[15][16]

Analyte signal decreases over time in processed samples

Degradation of Brivanib in the autosampler.

Analyze samples immediately after preparation. Investigate the stability of Brivanib in the reconstitution solvent at the autosampler temperature. If degradation is observed, consider using a cooler autosampler temperature or stabilizing agents.

Troubleshooting Matrix Effects

Observed Problem	Potential Causes	Recommended Solutions
<p data-bbox="135 741 435 819">Ion suppression or enhancement observed</p>	<p data-bbox="564 719 925 846">Co-elution of endogenous matrix components (e.g., phospholipids) with Brivanib.</p>	<p data-bbox="994 338 1382 1227">Optimize the chromatographic method to improve the separation of Brivanib from interfering matrix components. This can be achieved by modifying the mobile phase composition, gradient profile, or using a different stationary phase. Enhance the sample cleanup procedure. SPE, particularly using a mixed-mode sorbent, is generally more effective at removing interfering matrix components than PPT or LLE.[6] Use a stable isotope-labeled internal standard, which can effectively compensate for matrix effects. [17]</p>
<p data-bbox="135 1509 507 1588">High variability in recovery between different sample lots</p>	<p data-bbox="564 1487 895 1615">Inconsistent matrix effects across different biological samples.</p>	<p data-bbox="994 1272 1388 1825">Evaluate matrix effects using at least six different lots of the biological matrix. If significant variability is observed, a more robust sample cleanup method, such as SPE, is recommended over simpler methods like PPT. The use of a stable isotope-labeled internal standard is highly recommended to normalize for this variability.</p>

III. Experimental Protocols

Protein Precipitation (PPT) for Brivanib from Human Plasma

This protocol is a general procedure for the extraction of tyrosine kinase inhibitors and should be optimized for Brivanib.

- Sample Preparation:
 - To 100 μL of human plasma in a microcentrifuge tube, add 25 μL of an internal standard solution (e.g., [$^{13}\text{C}_3,^{15}\text{N}_2$]BMS-540215 in methanol).
- Protein Precipitation:
 - Add 300 μL of cold acetonitrile to the plasma sample.
 - Vortex the mixture vigorously for 1 minute.
- Centrifugation:
 - Centrifuge the sample at 10,000 $\times g$ for 10 minutes at 4°C to pellet the precipitated proteins.
- Supernatant Transfer:
 - Carefully transfer the supernatant to a clean tube.
- Evaporation and Reconstitution:
 - Evaporate the supernatant to dryness under a gentle stream of nitrogen at approximately 40°C.
 - Reconstitute the residue in 100 μL of the initial mobile phase.
- Analysis:
 - Vortex the reconstituted sample and inject an aliquot into the LC-MS/MS system.

Solid-Phase Extraction (SPE) for Brivanib from Human Plasma

This protocol is a general procedure and should be optimized for Brivanib using a suitable SPE cartridge (e.g., a mixed-mode cation exchange or reversed-phase C18).

- Sample Pre-treatment:
 - To 200 μ L of human plasma, add 200 μ L of 4% phosphoric acid in water.
 - Vortex for 30 seconds.
- SPE Cartridge Conditioning:
 - Condition the SPE cartridge with 1 mL of methanol followed by 1 mL of water. Do not allow the sorbent to dry.
- Sample Loading:
 - Load the pre-treated sample onto the conditioned SPE cartridge at a slow and steady flow rate (approximately 1 mL/min).
- Washing:
 - Wash the cartridge with 1 mL of 0.1% formic acid in water to remove polar impurities.
 - Wash the cartridge with 1 mL of 20% methanol in water to remove less polar impurities.
- Elution:
 - Elute Brivanib from the cartridge with 1 mL of a suitable elution solvent (e.g., 5% ammonium hydroxide in methanol).
- Evaporation and Reconstitution:
 - Evaporate the eluate to dryness under a gentle stream of nitrogen at approximately 40°C.
 - Reconstitute the residue in 100 μ L of the initial mobile phase.

- Analysis:
 - Vortex the reconstituted sample and inject an aliquot into the LC-MS/MS system.

IV. Data Presentation

The following tables summarize hypothetical quantitative data for Brivanib recovery to illustrate the expected performance of different extraction methods. Actual results may vary and should be determined experimentally.

Table 1: Comparison of Brivanib Recovery from Human Plasma using Different Extraction Methods

Extraction Method	Mean Recovery (%)	RSD (%) (n=6)	Matrix Effect (%)
Protein Precipitation (Acetonitrile)	85.2	8.5	75.6 (Suppression)
Liquid-Liquid Extraction (MTBE)	92.5	6.2	88.3 (Suppression)
Solid-Phase Extraction (Mixed-Mode)	98.7	3.1	95.1 (Minimal Effect)

Table 2: Brivanib Stability in Human Plasma at Different Storage Conditions

Storage Condition	Time Point	Mean Recovery (%) vs. Initial
Room Temperature (~22°C)	4 hours	98.5
24 hours	85.1	
Refrigerated (4°C)	24 hours	99.2
72 hours	97.8	
Frozen (-20°C)	1 month	99.5
3 months	98.9	
Frozen (-70°C)	6 months	99.8
12 months	99.6	
Freeze-Thaw Cycles (-70°C to RT)	1 cycle	99.7
3 cycles	96.4	

V. Mandatory Visualizations

Brivanib Mechanism of Action: Inhibition of VEGFR and FGFR Signaling

Brivanib is a dual inhibitor of Vascular Endothelial Growth Factor Receptor (VEGFR) and Fibroblast Growth Factor Receptor (FGFR).^[18] By blocking the ATP-binding site of these receptor tyrosine kinases, Brivanib inhibits downstream signaling pathways that are crucial for tumor angiogenesis and cell proliferation.^{[3][19]}

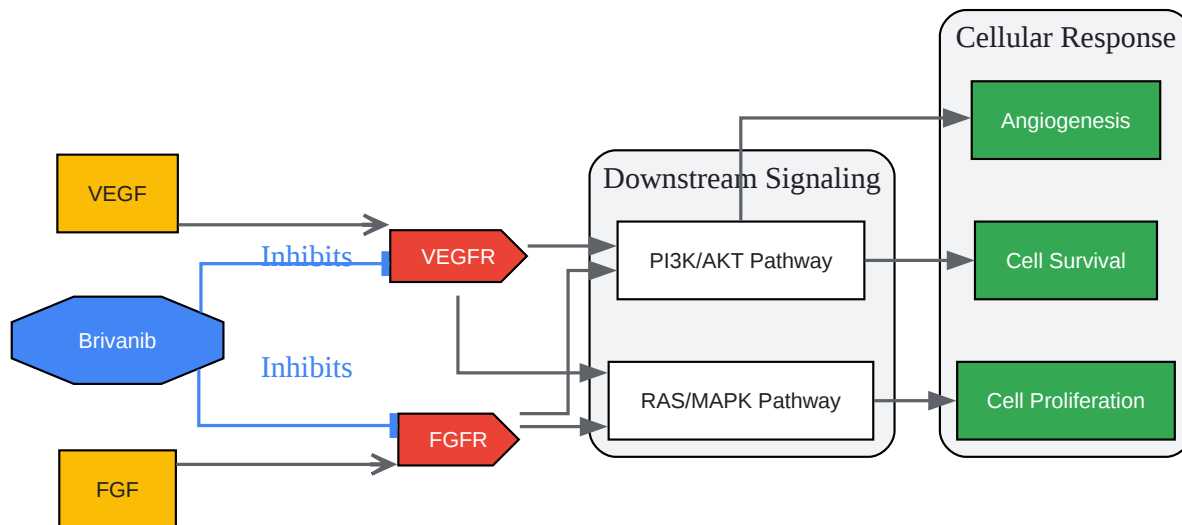

[Click to download full resolution via product page](#)

Brivanib inhibits VEGFR and FGFR signaling pathways.

Experimental Workflow for Brivanib Extraction from Plasma

The following diagram illustrates a typical workflow for the extraction and analysis of Brivanib from plasma samples.

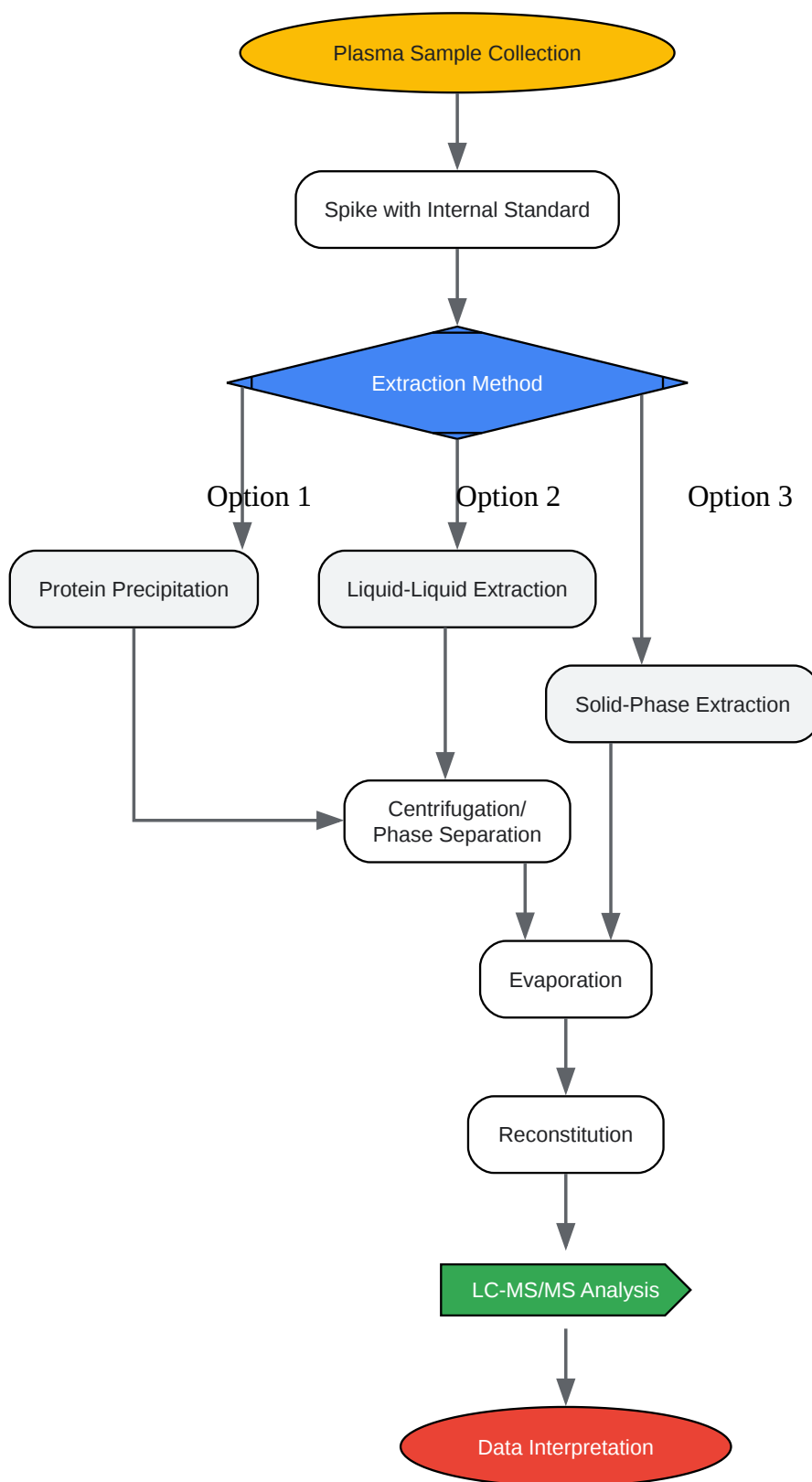

[Click to download full resolution via product page](#)

Workflow for Brivanib extraction and analysis.

Need Custom Synthesis?

BenchChem offers custom synthesis for rare earth carbides and specific isotopic labeling.

Email: info@benchchem.com or [Request Quote Online](#).

References

- 1. Pretreatment and analysis techniques development of TKIs in biological samples for pharmacokinetic studies and therapeutic drug monitoring - PMC [[pmc.ncbi.nlm.nih.gov](https://pubmed.ncbi.nlm.nih.gov/)]
- 2. [researchgate.net](https://www.researchgate.net/) [[researchgate.net](https://www.researchgate.net/)]
- 3. Metabolism, Excretion, and Pharmacokinetics of Oral Brivanib in Patients with Advanced or Metastatic Solid Tumors - PMC [[pmc.ncbi.nlm.nih.gov](https://pubmed.ncbi.nlm.nih.gov/)]
- 4. TROUBLE SHOOTING DURING BIOANALYTICAL ESTIMATION OF DRUG AND METABOLITES USING LC-MS/MS: A REVIEW - PMC [[pmc.ncbi.nlm.nih.gov](https://pubmed.ncbi.nlm.nih.gov/)]
- 5. [researchgate.net](https://www.researchgate.net/) [[researchgate.net](https://www.researchgate.net/)]
- 6. Systematic and comprehensive strategy for reducing matrix effects in LC/MS/MS analyses - PubMed [pubmed.ncbi.nlm.nih.gov]
- 7. [chromatographyonline.com](https://www.chromatographyonline.com/) [[chromatographyonline.com](https://www.chromatographyonline.com/)]
- 8. Overview, consequences, and strategies for overcoming matrix effects in LC-MS analysis: a critical review - Analyst (RSC Publishing) [pubs.rsc.org]
- 9. Stability studies of vorinostat and its two metabolites in human plasma, serum and urine. - Biospecimen Research Database [brd.nci.nih.gov]
- 10. Stability of Drugs, Drug Candidates, and Metabolites in Blood and Plasma - PubMed [pubmed.ncbi.nlm.nih.gov]
- 11. [benchchem.com](https://www.benchchem.com/) [[benchchem.com](https://www.benchchem.com/)]
- 12. [filtrous.com](https://www.filtrous.com/) [[filtrous.com](https://www.filtrous.com/)]
- 13. Protein Precipitation Methods for Proteomics [[biosyn.com](https://www.biosyn.com/)]
- 14. [chromatographyonline.com](https://www.chromatographyonline.com/) [[chromatographyonline.com](https://www.chromatographyonline.com/)]
- 15. [benchchem.com](https://www.benchchem.com/) [[benchchem.com](https://www.benchchem.com/)]
- 16. Pitfalls and solutions in the development of a fully automated solid-phase extraction method for drug screening purposes in plasma and whole blood - PubMed [pubmed.ncbi.nlm.nih.gov]

- [17. researchgate.net \[researchgate.net\]](https://www.researchgate.net)
- [18. Brivanib alaninate - Wikipedia \[en.wikipedia.org\]](https://en.wikipedia.org)
- [19. ar.iiarjournals.org \[ar.iiarjournals.org\]](https://ar.iiarjournals.org)
- To cite this document: BenchChem. [Technical Support Center: Brivanib Recovery from Biological Samples]. BenchChem, [2026]. [Online PDF]. Available at: [\[https://www.benchchem.com/product/b12381546/docs#technical-support-center-brivanib-recovery-from-biological-samples\]](https://www.benchchem.com/product/b12381546/docs#technical-support-center-brivanib-recovery-from-biological-samples)

Disclaimer & Data Validity:

The information provided in this document is for Research Use Only (RUO) and is strictly not intended for diagnostic or therapeutic procedures. While BenchChem strives to provide accurate protocols, we make no warranties, express or implied, regarding the fitness of this product for every specific experimental setup.

Technical Support: The protocols provided are for reference purposes. Unsure if this reagent suits your experiment?

Need Industrial/Bulk Grade? [Request Custom Synthesis Quote](#)

BenchChem

Our mission is to be the trusted global source of essential and advanced chemicals, empowering scientists and researchers to drive progress in science and industry.

Contact

Address: 3281 E Guasti Rd
Ontario, CA 91761, United States
Phone: (601) 213-4426
Email: info@benchchem.com

[Contact our Ph.D. Support Team for a compatibility check](#)

