

# Technical Support Center: AG5.0 Western Blot Analysis

**Author:** BenchChem Technical Support Team. **Date:** April 2026

## Compound of Interest

Compound Name: AG5.0  
Cat. No.: B12381149

[Get Quote](#)

Welcome to the technical support center for the **AG5.0** Western Blot Analysis protocol. This guide is designed for researchers, scientists, and drug development professionals to troubleshoot common issues and provide clear, actionable solutions.

## Troubleshooting Guide

This section addresses specific problems you may encounter during your **AG5.0** Western Blot experiment in a question-and-answer format.

### Weak or No Signal

Question: Why am I not seeing any bands or only very faint bands on my blot?

Potential Causes and Solutions:

- **Inactive Antibody:** The primary or secondary antibody may have lost activity due to improper storage or expiration. You can test the antibody's activity with a dot blot.[\[1\]](#)[\[2\]](#)
- **Incorrect Antibody Concentration:** The concentration of the primary or secondary antibody may be too low. Try increasing the antibody concentration or extending the incubation time.

[1][3] It's recommended to perform an antibody titration to determine the optimal concentration.[4]

- **Low Target Protein Abundance:** The protein of interest may be in low abundance in your sample. To address this, you can load more protein onto the gel or enrich your sample for the target protein through methods like immunoprecipitation.[2][5]
- **Inefficient Protein Transfer:** The transfer of proteins from the gel to the membrane may have been inefficient. You can verify the transfer efficiency by staining the membrane with Ponceau S after transfer.[5][6] Ensure there are no air bubbles between the gel and the membrane.[5][7]
- **Blocking Agent Issues:** The blocking buffer might be masking the antigen. You can try using a different blocking agent or reducing the concentration of the blocking agent.[2][8] For phosphorylated proteins, avoid using milk-based blockers as they contain casein, a phosphoprotein that can cause high background.[9]
- **Inhibitors Present:** Sodium azide is an inhibitor of Horseradish Peroxidase (HRP), a common enzyme conjugated to secondary antibodies. Ensure your buffers do not contain sodium azide if you are using an HRP-conjugated secondary antibody.[1]
- **Insufficient Exposure:** The exposure time for detecting the chemiluminescent signal may be too short. Try increasing the exposure time.[1]

## High Background

Question: What is causing the high background on my Western blot, making it difficult to see my bands?

Potential Causes and Solutions:

- **Antibody Concentration Too High:** The concentration of the primary or secondary antibody may be too high, leading to non-specific binding. Reduce the antibody concentration.[1][9][10]
- **Insufficient Blocking:** The blocking step may be inadequate. Increase the blocking time, the concentration of the blocking agent, or try a different blocking agent.[1][8][9] Adding a

detergent like Tween 20 to the blocking buffer can also help.[\[8\]](#)[\[9\]](#)

- **Inadequate Washing:** Insufficient washing can leave unbound antibodies on the membrane. Increase the number and duration of wash steps.[\[1\]](#)[\[11\]](#) Including a detergent like Tween 20 in the wash buffer is also recommended.[\[1\]](#)[\[11\]](#)
- **Membrane Handled Improperly:** Touching the membrane with your hands or contaminated forceps can lead to background issues. Always handle the membrane with clean forceps.[\[1\]](#)
- **Membrane Dried Out:** Allowing the membrane to dry out at any stage can cause high background.[\[9\]](#)[\[10\]](#)[\[12\]](#)
- **Contaminated Buffers:** Buffers, especially the blocking buffer, can become contaminated with bacteria, which can cause a speckled background. Prepare fresh buffers and filter them if necessary.[\[1\]](#)[\[12\]](#)

## Nonspecific Bands

Question: Why am I seeing extra, unexpected bands on my blot?

Potential Causes and Solutions:

- **Antibody Concentration Too High:** A high concentration of the primary antibody can lead to it binding to proteins other than the target.[\[1\]](#)[\[13\]](#)
- **Low Antibody Specificity:** The primary antibody may not be specific enough for your target protein.[\[14\]](#) Consider using a more specific antibody or purifying your current antibody.
- **Too Much Protein Loaded:** Overloading the gel with too much protein can result in "ghost bands" and nonspecific binding.[\[1\]](#)[\[13\]](#)
- **Protein Degradation:** If you see bands at a lower molecular weight than expected, your protein may have been degraded by proteases. Always add protease inhibitors to your sample preparation buffers.[\[13\]](#)
- **Post-Translational Modifications:** Glycosylation and other modifications can cause proteins to migrate at a higher molecular weight than predicted.[\[8\]](#)[\[15\]](#)

- **Secondary Antibody Nonspecificity:** The secondary antibody may be binding non-specifically. Run a control where you omit the primary antibody to check for this.[\[9\]](#)

## Irregular Staining and "Smiling" Bands

Question: My bands are curved or look like a "smile." What causes this?

Potential Causes and Solutions:

- **Uneven Gel Polymerization:** If you pour your own gels, ensure they polymerize evenly.[\[6\]](#)[\[16\]](#)
- **Uneven Heat Distribution:** Running the gel at too high a voltage can cause uneven heat distribution, leading to "smiling" bands. Try running the gel at a lower voltage for a longer time.[\[16\]](#)[\[17\]](#)
- **Improperly Prepared Samples or Buffers:** Ensure your samples and running buffer are prepared correctly and are at the correct pH.[\[16\]](#)

## Quantitative Data Summary

Parameter	Recommendation	Troubleshooting Tips
Protein Load	20-30 µg for cell lysates[13]	Too much protein can cause streaking and nonspecific bands.[1] Too little can result in a weak or no signal.
Primary Antibody Dilution	Typically 1:500 to 1:2000[18]	Titrate to find the optimal concentration. Too high can cause high background and nonspecific bands.[1][9]
Secondary Antibody Dilution	Typically 1:5000 to 1:20,000[18]	Titrate to find the optimal concentration. Too high can cause high background.[9]
Blocking Time	1 hour at room temperature or overnight at 4°C[1][8]	Insufficient blocking can lead to high background.[9]
Washing Steps	3-5 washes of 5-10 minutes each	Inadequate washing is a common cause of high background.[1]
Tween 20 Concentration	0.05% - 0.1% in wash and blocking buffers[1][13]	Helps to reduce nonspecific binding and background.

## Experimental Protocol: AG5.0 Western Blot

This protocol outlines the key steps for performing a Western blot using the **AG5.0** methodology.

- Sample Preparation:
  - Lyse cells or tissues in RIPA buffer supplemented with protease and phosphatase inhibitors.
  - Determine protein concentration using a BCA or Bradford assay.
  - Mix the desired amount of protein with Laemmli sample buffer and heat at 95-100°C for 5 minutes.

- SDS-PAGE:
  - Load 20-30 µg of protein per well onto a polyacrylamide gel.
  - Run the gel at a constant voltage until the dye front reaches the bottom.
- Protein Transfer:
  - Equilibrate the gel, membrane (PVDF or nitrocellulose), and filter paper in transfer buffer.
  - Assemble the transfer stack, ensuring no air bubbles are trapped between the gel and the membrane.
  - Transfer the proteins to the membrane. Transfer times and voltages will vary depending on the protein size and transfer system.
- Blocking:
  - Block the membrane in 5% non-fat dry milk or 5% BSA in TBST (Tris-Buffered Saline with 0.1% Tween 20) for 1 hour at room temperature with gentle agitation.
- Primary Antibody Incubation:
  - Dilute the primary antibody in the blocking buffer at the predetermined optimal concentration.
  - Incubate the membrane with the primary antibody solution overnight at 4°C with gentle agitation.
- Washing:
  - Wash the membrane three times for 5-10 minutes each with TBST.
- Secondary Antibody Incubation:
  - Dilute the HRP-conjugated secondary antibody in the blocking buffer.

- Incubate the membrane with the secondary antibody solution for 1 hour at room temperature with gentle agitation.
- Washing:
  - Wash the membrane three times for 10 minutes each with TBST.
- Detection:
  - Incubate the membrane with a chemiluminescent substrate according to the manufacturer's instructions.
  - Capture the signal using an imaging system or film.

## Visualizations

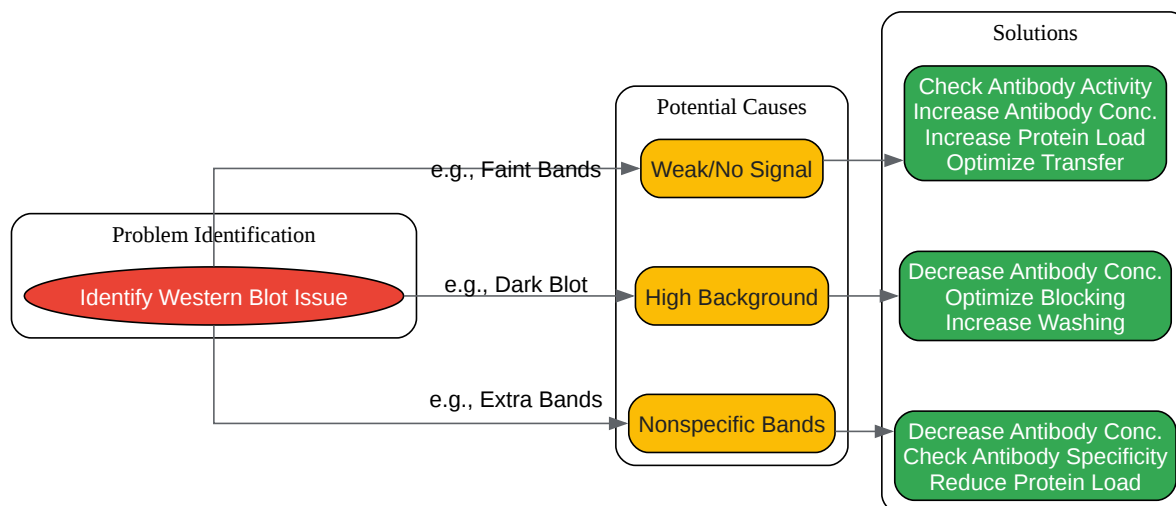

[Click to download full resolution via product page](#)

Caption: A workflow for troubleshooting common Western blot issues.

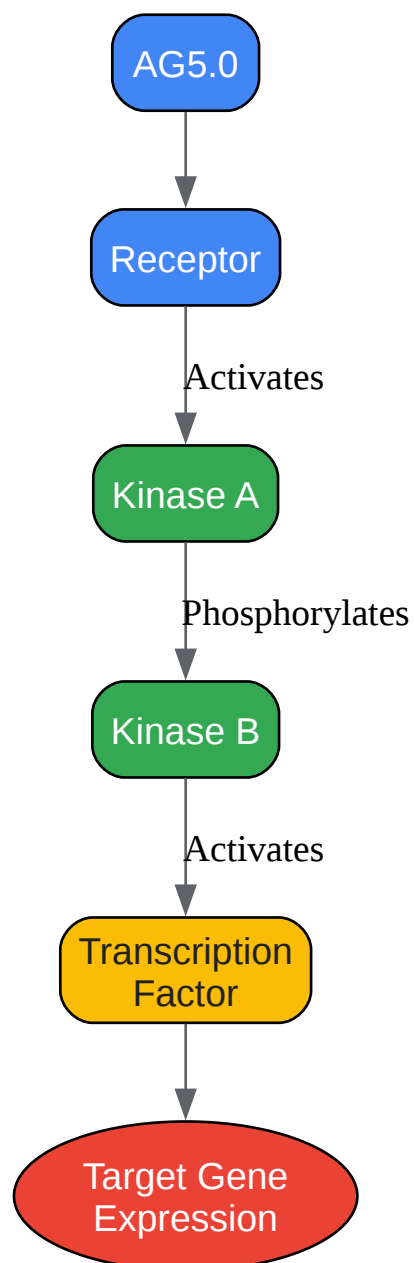

[Click to download full resolution via product page](#)

Caption: The **AG5.0** signaling pathway leading to gene expression.

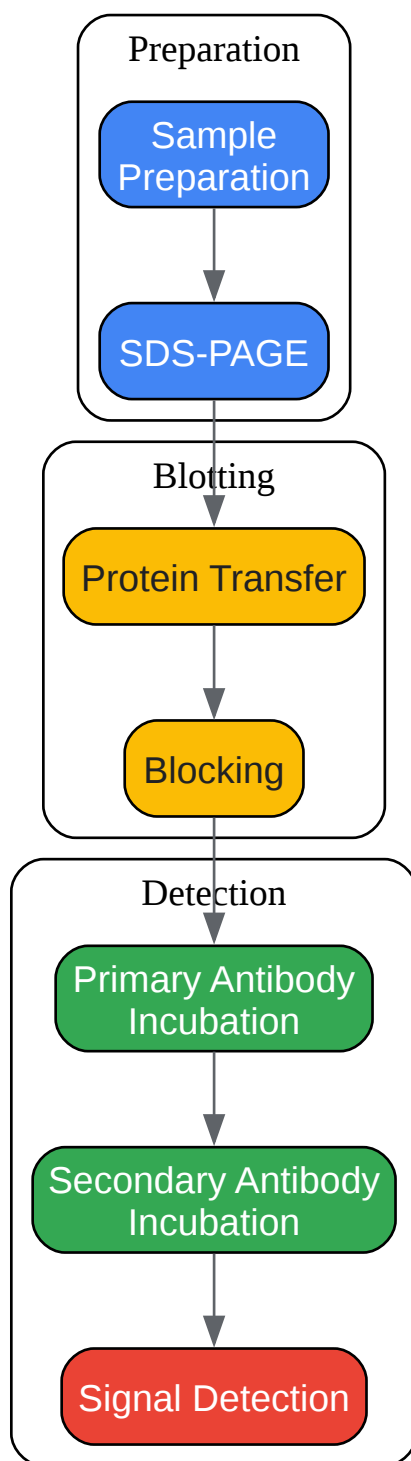

[Click to download full resolution via product page](#)

Caption: The experimental workflow for **AG5.0** Western blot analysis.

## Frequently Asked Questions (FAQs)

Q1: Can I reuse my primary antibody solution? A1: While it is possible to reuse the primary antibody solution, it is generally not recommended as it can lead to reduced signal and increased background over time due to decreased antibody stability and potential contamination.[15] For optimal results, it is best to use a freshly diluted antibody solution for each experiment.

Q2: What is the difference between PVDF and nitrocellulose membranes? A2: PVDF membranes are known for their physical strength and higher protein binding capacity, making them suitable for stripping and reprobing.[17] Nitrocellulose membranes, while more fragile, may offer lower background.[10][11] The choice of membrane can depend on the specific application and the abundance of the target protein.

Q3: How long should I expose my blot? A3: The optimal exposure time can vary significantly depending on the abundance of your target protein and the sensitivity of your detection reagents. It is often necessary to perform a series of exposures of varying lengths to determine the best one.[17]

Q4: Why is it important to include a loading control? A4: A loading control is a protein that is ubiquitously and consistently expressed across all samples. Probing for a loading control helps to confirm that an equal amount of protein was loaded in each lane and that the transfer was uniform across the gel.[5]

Q5: What should I do if I see "ghost bands" on my blot? A5: Ghost bands can appear if the membrane is not stripped completely before reprobing or due to improper antibody binding.[16] Ensure your stripping protocol is effective and optimize your antibody concentrations.

### Need Custom Synthesis?

BenchChem offers custom synthesis for rare earth carbides and specific isotopic labeling.

Email: [info@benchchem.com](mailto:info@benchchem.com) or [Request Quote Online](#).

## References

- 1. [Western Blot Troubleshooting | Thermo Fisher Scientific - HK \[thermofisher.com\]](#)

- [2. sinobiological.com \[sinobiological.com\]](#)
- [3. bio-rad-antibodies.com \[bio-rad-antibodies.com\]](#)
- [4. How To Optimize Your Western Blot | Proteintech Group \[ptglab.com\]](#)
- [5. Western Blot Troubleshooting: Weak/No Signal & Other | Proteintech Group \[ptglab.com\]](#)
- [6. Western Blot Troubleshooting Guide - TotalLab \[totallab.com\]](#)
- [7. cytivalifesciences.com \[cytivalifesciences.com\]](#)
- [8. bosterbio.com \[bosterbio.com\]](#)
- [9. Western Blot Troubleshooting: High Background | Proteintech Group \[ptglab.com\]](#)
- [10. sinobiological.com \[sinobiological.com\]](#)
- [11. biossusa.com \[biossusa.com\]](#)
- [12. bio-rad.com \[bio-rad.com\]](#)
- [13. arp1.com \[arp1.com\]](#)
- [14. azurebiosystems.com \[azurebiosystems.com\]](#)
- [15. Western Blotting Troubleshooting Guide | Cell Signaling Technology \[cellsignal.com\]](#)
- [16. Western Blot Troubleshooting: 10 Common Problems and Solutions \[synapse.patsnap.com\]](#)
- [17. 7 Tips For Optimizing Your Western Blotting Experiments | Proteintech Group | 武汉三鹰生物技术有限公司 \[ptgcn.com\]](#)
- [18. promegaconnections.com \[promegaconnections.com\]](#)
- To cite this document: BenchChem. [Technical Support Center: AG5.0 Western Blot Analysis]. BenchChem, [2026]. [Online PDF]. Available at: [\[https://www.benchchem.com/product/b12381149/docs#technical-support-center-ag5-0-western-blot-analysis\]](https://www.benchchem.com/product/b12381149/docs#technical-support-center-ag5-0-western-blot-analysis)

---

### Disclaimer & Data Validity:

The information provided in this document is for Research Use Only (RUO) and is strictly not intended for diagnostic or therapeutic procedures. While BenchChem strives to provide accurate protocols, we make no warranties, express or implied, regarding the fitness of this product for every specific experimental setup.

**Technical Support:** The protocols provided are for reference purposes. Unsure if this reagent suits your experiment?

**Need Industrial/Bulk Grade?** [Request Custom Synthesis Quote](#)

## BenchChem

Our mission is to be the trusted global source of essential and advanced chemicals, empowering scientists and researchers to drive progress in science and industry.

### Contact

Address: 3281 E Guasti Rd  
Ontario, CA 91761, United States  
Phone: (601) 213-4426  
Email: [info@benchchem.com](mailto:info@benchchem.com)

[Contact our Ph.D. Support Team for a compatibility check](#)