

# Structural Modifications of Camptothecin for Improved Efficacy: A Technical Guide

**Author:** BenchChem Technical Support Team. **Date:** April 2026

## Compound of Interest

Compound Name: *Topoisomerase I inhibitor 12*

Cat. No.: *B12381055*

[Get Quote](#)

**Abstract:** Camptothecin (CPT), a potent pentacyclic quinoline alkaloid, is a well-established inhibitor of DNA topoisomerase I (Top1), exhibiting significant antitumor activity across a range of cancers.[1][2] However, its clinical application is hampered by inherent limitations, including poor water solubility, instability of the active lactone E-ring at physiological pH, and significant toxicity.[1][3][4][5] This has driven extensive research into structural modifications to enhance its therapeutic index. This technical guide provides an in-depth overview of the key strategies employed to modify the CPT scaffold, focusing on A, B, and E-ring alterations, and the development of prodrugs and advanced delivery systems. We present comparative quantitative data on the efficacy of various analogs, detail key experimental protocols for their evaluation, and illustrate the underlying mechanisms and workflows through diagrams.

## Introduction to Camptothecin (CPT)

### Discovery and Mechanism of Action

Isolated in 1966 from the Chinese tree *Camptotheca acuminata*, camptothecin exerts its cytotoxic effects through a unique mechanism of action.[3][4] It specifically targets the DNA-Top1 covalent complex, an transient intermediate formed during DNA replication and transcription.[6][7] CPT intercalates into this complex, preventing the Top1-mediated religation of the single-strand DNA break.[4][6][8] The collision of a replication fork with this stabilized

"cleavable complex" results in an irreversible double-strand DNA break, ultimately triggering apoptosis.[4] The key structural features required for this activity are the planar pentacyclic ring system and the  $\alpha$ -hydroxy lactone E-ring with a (S) configuration at the C-20 position.[4][9]

## Limitations of Native Camptothecin

The clinical development of CPT was initially halted due to several unfavorable properties:

- **Poor Water Solubility:** CPT is poorly soluble in aqueous solutions, making formulation and administration challenging.[4][5][10]
- **Lactone Ring Instability:** The crucial  $\alpha$ -hydroxy lactone E-ring is susceptible to hydrolysis under physiological conditions (pH 7.4), converting to an inactive, water-soluble carboxylate form.[1][11][12][13] This equilibrium heavily favors the inactive form, reducing the drug's efficacy.
- **Toxicity:** The initial clinical trials using the water-soluble sodium salt of the carboxylate form showed severe and unpredictable toxicities, including hemorrhagic cystitis and myelosuppression.[4][14]
- **Drug Resistance:** Efficacy can be limited by chemoresistance mechanisms, such as the overexpression of efflux pumps like ABCG2 (Breast Cancer Resistance Protein).[15]

## Strategies for Structural Modification

To overcome these limitations, medicinal chemists have focused on modifying the A, B, and E rings of the CPT scaffold. The most successful modifications have led to clinically approved drugs and promising next-generation candidates.

### A- and B-Ring Modifications

Modifications on the A and B rings are primarily aimed at improving water solubility and enhancing interactions with the Top1-DNA complex. These substitutions have led to some of the most successful CPT analogs.

- **Topotecan (Hycamtin®):** A semi-synthetic analog with a dimethylaminomethyl group at the C-9 position and a hydroxyl group at C-10. This modification increases water solubility, allowing for intravenous administration.[14][16]

- Irinotecan (CPT-11, Camptosar®): A prodrug with a dipiperidino carbamate side chain at C-10.[12] It is converted in vivo by carboxylesterase enzymes to its highly active metabolite, SN-38 (7-ethyl-10-hydroxycamptothecin), which is 100- to 1000-fold more potent than irinotecan itself.[12][17]
- 9-Nitrocamptothecin (Rubitecan) and 9-Aminocamptothecin (9-AC): These A-ring modified compounds showed promise, with Rubitecan being developed as an oral formulation.[4] 9-AC is the active metabolite of 9-NC.[4]
- Exatecan (DX-8951f): A water-soluble, hexacyclic analog with modifications on the A and B rings that does not require enzymatic activation.[18] It has shown potent antitumor activity and the ability to overcome P-glycoprotein-mediated multidrug resistance.[18]

## E-Ring Modifications

The instability of the E-ring lactone is a major drawback. Modifications to this ring aim to increase its stability while retaining Top1 inhibitory activity.

- Homocamptothecins (hCPT): These analogs feature a seven-membered  $\beta$ -hydroxylactone E-ring, created by inserting a methylene spacer.[11][19] This modification results in a less reactive but more stable lactone that is less prone to hydrolysis.[11][20] Despite the reduced reactivity, hCPTs retain and can even enhance Top1 poisoning activity and in vivo efficacy compared to CPT.[11][21] For instance, a difluorinated hCPT (BN 80915) entered clinical trials.[21] Studies have shown that after 24 hours at pH 7.4, 87% of hCPT remains in its intact lactone form, compared to CPT which reaches an equilibrium with only about 20% lactone within an hour.[20]

## Development of Water-Soluble Prodrugs and Formulations

Another major strategy involves attaching hydrophilic moieties to the CPT core, often at the C-20 hydroxyl group, to create water-soluble prodrugs.

- Phosphate and Phosphonate Analogues: Attaching phosphate groups to the 20-hydroxyl position yields freely water-soluble analogues that are stable at physiological pH and retain the ability to stabilize the Top1-DNA complex.[16][22]

- PEGylation: Conjugating polyethylene glycol (PEG) to CPT can improve solubility and pharmacokinetic properties.[12]
- Polymer-based Prodrugs: Multivalent, polymer-based prodrugs of structurally optimized CPTs, such as PEG-[SN22]4, have been developed to overcome chemoresistance and increase tumor drug exposure.[15]

## Nanoparticle-based Drug Delivery Systems

Encapsulating CPT or its derivatives into nanocarriers is a promising approach to improve solubility, stability, and tumor targeting while reducing systemic toxicity.[3][23] Nanotechnology-based systems can leverage the enhanced permeability and retention (EPR) effect for passive tumor accumulation.[3] Various platforms, including liposomes, polymeric nanoparticles, and cyclodextrins, have been investigated to deliver CPT effectively.[5][24] Liposomal irinotecan (Onivyde®) is a clinically approved formulation that demonstrates the success of this strategy. [13]

## Quantitative Efficacy Data of CPT Analogs

The following tables summarize key quantitative data for representative CPT analogs, allowing for a direct comparison of their biological activities and properties.

Table 1: In Vitro Cytotoxicity of Selected Camptothecin Analogs

Compound	Cell Line	IC50 (nM)	Reference
Camptothecin (CPT)	A549 (Lung)	15.8	[25]
	HCT-116 (Colon)	8.7	[25]
SN-38	A549 (Lung)	3.2	[25]
	HCT-116 (Colon)	1.9	[25]
Topotecan	P388 (Leukemia)	20	[18]
DX-8951f (Exatecan)	P388 (Leukemia)	0.52	[18]
B7 (CPT Derivative)	A549 (Lung)	1.1	[25]
	HCT-116 (Colon)	0.8	[25]
15b (Hexacyclic CPT)	A549 (Lung)	0.005 $\mu$ M	[26]

| | WiDr (Colon) | 0.003  $\mu$ M |[26] |

Table 2: In Vivo Antitumor Efficacy of Selected Camptothecin Analogs

Compound	Xenograft Model	Dosage	Tumor Growth Inhibition (%)	Reference
CPT	HT-29 (Colon)	0.625 mg/kg/day	- (Tumor growth delay of 4 days)	[20]
Fluorinated hCPT (23g)	HT-29 (Colon)	0.32 mg/kg/day	- (Tumor growth delay of 25 days)	[20]
DX-8951f (Exatecan)	SC-6 (Gastric)	25 mg/kg (q4d x3)	>90%	[18]
CPT-11 (Irinotecan)	SC-6 (Gastric)	100 mg/kg (q4d x3)	~80%	[18]
B7 (CPT Derivative)	A549 (Lung)	2.0 mg/kg	Significant inhibition	[25]
36o (hCPT Derivative)	HT-29 (Colon)	3.0 mg/kg	Significant activity	[27]

| 15b (Hexacyclic CPT) | WiDr (Colon) | 20 mg/kg | Higher than SN-38 [[26] ]

Table 3: Physicochemical Properties of Selected Camptothecin Analogs

Compound	Property	Value	Reference
Camptothecin	Lactone Stability	~20% remains after 1h at pH 7.4	[20]
Homocamptothecin (hCPT)	Lactone Stability	87% remains after 24h at pH 7.4	[20]
B7 (CPT Derivative)	Water Solubility	5.73 µg/mL	[25]

| 36o (hCPT Derivative) | Water Solubility | 1.2 mg/mL [[27] ]

## Key Experimental Protocols

## Topoisomerase I Cleavage Assay

This assay is fundamental to determining if a CPT analog retains the mechanism of action of the parent compound.

Methodology:

- **Reaction Mixture:** Supercoiled plasmid DNA (e.g., pBR322) is incubated with purified human Topoisomerase I in a reaction buffer (e.g., 10 mM Tris-HCl, pH 7.5, 50 mM KCl, 5 mM MgCl<sub>2</sub>, 0.1 mM EDTA, and 15 µg/ml bovine serum albumin).
- **Drug Addition:** The test compound (CPT analog) is added at various concentrations. A control reaction without the drug is run in parallel.
- **Incubation:** The reaction is incubated at 37°C for 30 minutes to allow the formation of the cleavable complex.
- **Termination:** The reaction is stopped by adding SDS (to a final concentration of 1%) and proteinase K. This traps the covalent DNA-Top1 complex by denaturing the enzyme.
- **Analysis:** The DNA is analyzed by agarose gel electrophoresis. CPT and its active analogs inhibit the religation step, leading to an accumulation of nicked, open-circular DNA and a decrease in relaxed DNA.<sup>[28][29]</sup> The amount of nicked DNA is quantified to determine the inhibitory potency of the compound.

## In Vitro Cytotoxicity Assay (MTT Assay)

This assay measures the metabolic activity of cells and is commonly used to determine the concentration of a drug that inhibits cell growth by 50% (IC<sub>50</sub>).

Methodology:

- **Cell Seeding:** Human tumor cells (e.g., A549, HCT-116) are seeded in 96-well plates and incubated for 24 hours to allow for attachment.
- **Drug Treatment:** The cells are treated with a range of concentrations of the test compounds and incubated for a further 72 hours.

- **MTT Addition:** 10  $\mu$ L of MTT solution (5 mg/mL in PBS) is added to each well, and the plate is incubated for 4 hours at 37°C. Viable cells with active mitochondrial dehydrogenases will reduce the yellow MTT to purple formazan crystals.
- **Solubilization:** The medium is removed, and 100  $\mu$ L of DMSO is added to each well to dissolve the formazan crystals.
- **Measurement:** The absorbance is measured using a microplate reader at a wavelength of 550 nm.<sup>[30]</sup> The IC50 value is calculated from the dose-response curve.

## Lactone Stability Assay (HPLC)

This assay quantifies the rate of hydrolysis of the CPT analog's lactone ring to the inactive carboxylate form.

Methodology:

- **Sample Preparation:** A stock solution of the CPT analog is prepared in a suitable solvent (e.g., DMSO) and then diluted in a buffer solution at physiological pH (7.4) and human plasma.
- **Incubation:** The solution is incubated at 37°C.
- **Time Points:** Aliquots are taken at various time points (e.g., 0, 1, 2, 4, 8, 24 hours). The reaction is quenched, often by acidification, to prevent further hydrolysis.
- **HPLC Analysis:** The samples are analyzed by reverse-phase high-performance liquid chromatography (HPLC). The lactone and carboxylate forms typically have different retention times and can be separated and quantified.
- **Data Analysis:** The percentage of the intact lactone form remaining at each time point is plotted to determine the stability profile and half-life of the compound.

## In Vivo Xenograft Model

This protocol assesses the antitumor efficacy of a CPT analog in a living organism.

Methodology:

- Cell Implantation: Human tumor cells (e.g., A549, HT-29) are subcutaneously injected into the flank of immunocompromised mice (e.g., nude mice).
- Tumor Growth: Tumors are allowed to grow to a palpable size (e.g., 100-200 mm<sup>3</sup>).
- Treatment: Mice are randomized into control and treatment groups. The CPT analog is administered (e.g., intravenously, orally) according to a specific dosage and schedule (e.g., 2 mg/kg, once daily for 5 days). The control group receives the vehicle.
- Monitoring: Tumor volume and body weight are measured regularly (e.g., twice a week). Tumor volume is calculated using the formula:  $(\text{length} \times \text{width}^2)/2$ .
- Endpoint: The experiment is terminated when tumors in the control group reach a predetermined maximum size or at the end of the study period. The antitumor efficacy is evaluated by comparing the tumor growth inhibition in the treated groups versus the control group.<sup>[25][27]</sup>

## Signaling Pathways and Workflows

The following diagrams, created using Graphviz, illustrate key concepts related to camptothecin's mechanism and development.

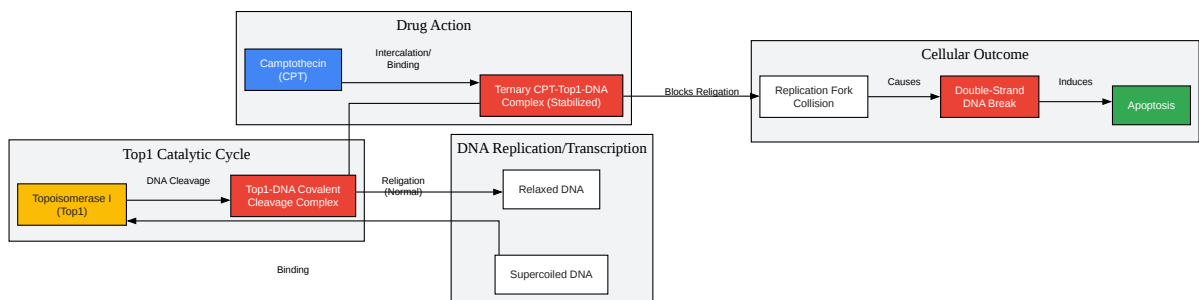

[Click to download full resolution via product page](#)

Caption: Mechanism of Topoisomerase I inhibition by Camptothecin.

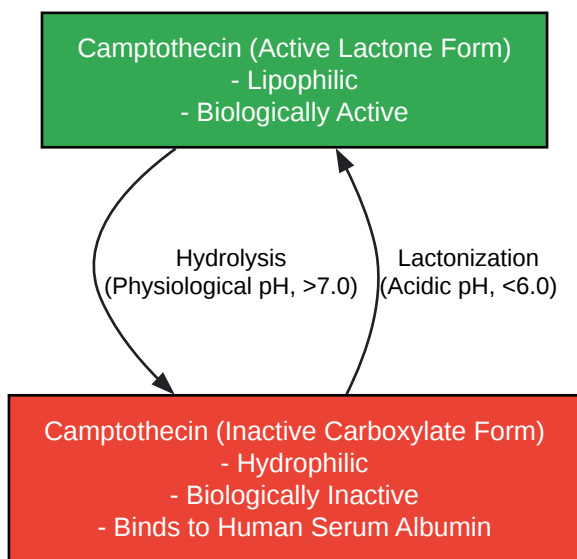

[Click to download full resolution via product page](#)

Caption: pH-dependent equilibrium of CPT's E-ring.

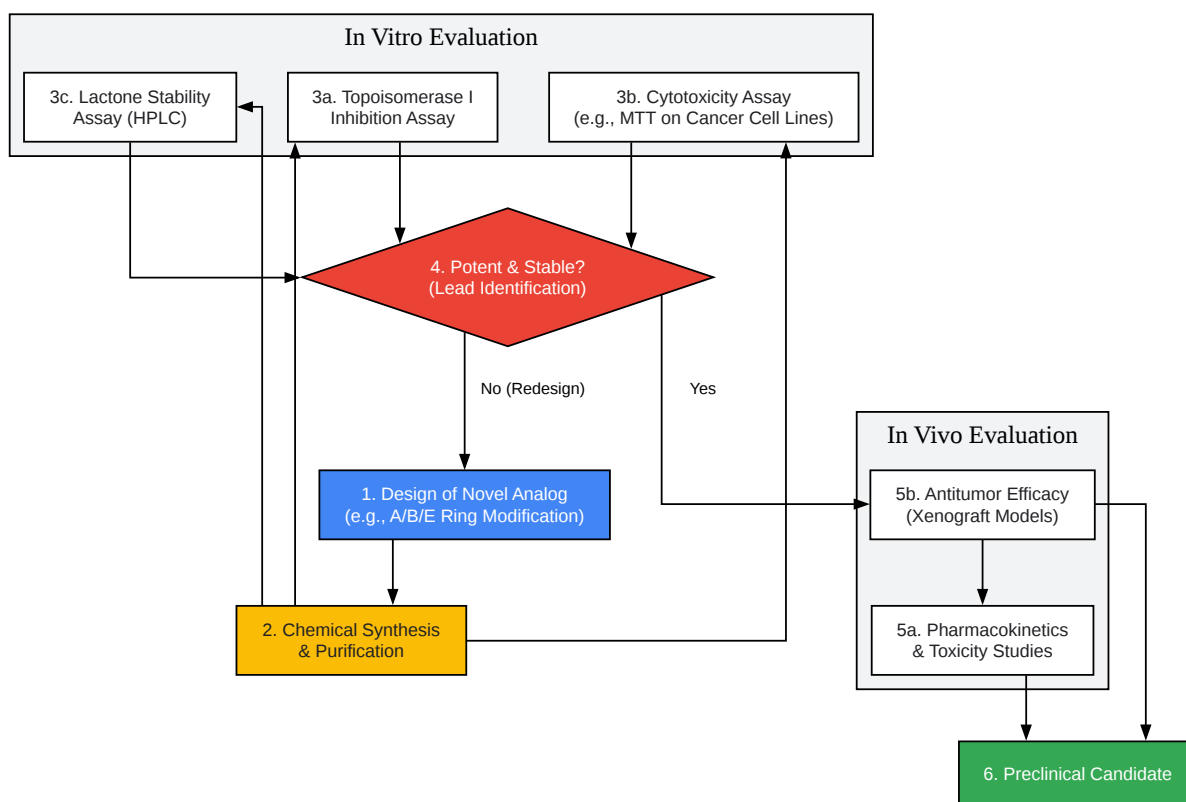

[Click to download full resolution via product page](#)

Caption: Workflow for the development of a novel CPT analog.

## Conclusion and Future Perspectives

The journey from the discovery of camptothecin to the clinical success of its analogs, Topotecan and Irinotecan, is a landmark in cancer chemotherapy. Structural modification has been pivotal in overcoming the parent compound's significant liabilities. A- and B-ring substitutions have successfully improved solubility and created effective prodrugs, while E-ring

modifications in homocamptothecins have enhanced lactone stability, a critical parameter for sustained activity.

The future of CPT-based therapies lies in more sophisticated and targeted approaches. The development of antibody-drug conjugates (ADCs) that use CPT derivatives as payloads, such as sacituzumab govitecan and trastuzumab deruxtecan, represents a major advancement, enabling selective delivery of the cytotoxic agent to tumor cells and improving the therapeutic window.[13] Furthermore, research into CPT analogs with novel mechanisms of action, potentially independent of Top1 inhibition, could open new avenues for overcoming resistance.[4] The combination of optimized CPT scaffolds with advanced, stimulus-responsive nanodelivery systems holds great promise for creating next-generation anticancer agents with superior efficacy and minimal side effects.[31]

#### *Need Custom Synthesis?*

*BenchChem offers custom synthesis for rare earth carbides and specific isotopic labeling.*

*Email: [info@benchchem.com](mailto:info@benchchem.com) or [Request Quote Online](#).*

## References

- [1. Evolution in medicinal chemistry of E-ring-modified Camptothecin analogs as anticancer agents - PubMed \[pubmed.ncbi.nlm.nih.gov\]](#)
- [2. Camptothecin and its analogues: a review on their chemotherapeutic potential \[pubmed.ncbi.nlm.nih.gov\]](#)
- [3. Camptothecin-based nanodrug delivery systems - PMC \[pmc.ncbi.nlm.nih.gov\]](#)
- [4. Camptothecin \(CPT\) and its derivatives are known to target topoisomerase I \(Top1\) as their mechanism of action: did we miss something in CPT analogue molecular targets for treating human disease such as cancer? - PMC \[pmc.ncbi.nlm.nih.gov\]](#)
- [5. researchgate.net \[researchgate.net\]](#)
- [6. Structure-based analysis of the effects of camptothecin on the activities of human topoisomerase I - PubMed \[pubmed.ncbi.nlm.nih.gov\]](#)
- [7. Human topoisomerase I inhibition: docking camptothecin and derivatives into a structure-based active site model - PubMed \[pubmed.ncbi.nlm.nih.gov\]](#)
- [8. researchgate.net \[researchgate.net\]](#)

- [9. Structural modifications of camptothecin and effects on topoisomerase I inhibition - PubMed \[pubmed.ncbi.nlm.nih.gov\]](#)
- [10. Camptothecin & Its Derivatives for Cancer Therapy | Biopharma PEG \[biochempeg.com\]](#)
- [11. Homocamptothecin, an E-ring modified camptothecin with enhanced lactone stability, retains topoisomerase I-targeted activity and antitumor properties - PubMed \[pubmed.ncbi.nlm.nih.gov\]](#)
- [12. Cancer Therapies Utilizing the Camptothecins: A Review of in Vivo Literature - PMC \[pmc.ncbi.nlm.nih.gov\]](#)
- [13. mdpi.com \[mdpi.com\]](#)
- [14. asu.elsevierpure.com \[asu.elsevierpure.com\]](#)
- [15. Structural Optimization and Enhanced Prodrug-Mediated Delivery Overcomes Camptothecin Resistance in High-Risk Solid Tumors - PubMed \[pubmed.ncbi.nlm.nih.gov\]](#)
- [16. pubs.acs.org \[pubs.acs.org\]](#)
- [17. mdpi.com \[mdpi.com\]](#)
- [18. A new water-soluble camptothecin derivative, DX-8951f, exhibits potent antitumor activity against human tumors in vitro and in vivo - PubMed \[pubmed.ncbi.nlm.nih.gov\]](#)
- [19. Homocamptothecins: synthesis and antitumor activity of novel E-ring-modified camptothecin analogues - PubMed \[pubmed.ncbi.nlm.nih.gov\]](#)
- [20. pubs.acs.org \[pubs.acs.org\]](#)
- [21. Homocamptothecins: E-ring modified CPT analogues - PubMed \[pubmed.ncbi.nlm.nih.gov\]](#)
- [22. pubs.acs.org \[pubs.acs.org\]](#)
- [23. Camptothecin-based nanodrug delivery systems | Cancer Biology & Medicine \[cancerbiomed.org\]](#)
- [24. Recent Advances in Improved Anticancer Efficacies of Camptothecin Nano-Formulations: A Systematic Review | MDPI \[mdpi.com\]](#)
- [25. Synthesis and Biological Evaluation of 10-Substituted Camptothecin Derivatives with Improved Water Solubility and Activity - PubMed \[pubmed.ncbi.nlm.nih.gov\]](#)
- [26. pure.dongguk.edu \[pure.dongguk.edu\]](#)
- [27. Design, synthesis and biological evaluation of novel homocamptothecin analogues as potent antitumor agents - PubMed \[pubmed.ncbi.nlm.nih.gov\]](#)

- [28. \[PDF\] Structure-activity study of the actions of camptothecin derivatives on mammalian topoisomerase I: evidence for a specific receptor site and a relation to antitumor activity. | Semantic Scholar \[semanticscholar.org\]](#)
- [29. Structure-activity study of the actions of camptothecin derivatives on mammalian topoisomerase I: evidence for a specific receptor site and a relation to antitumor activity - PubMed \[pubmed.ncbi.nlm.nih.gov\]](#)
- [30. tandfonline.com \[tandfonline.com\]](#)
- [31. pubs.acs.org \[pubs.acs.org\]](#)
- [To cite this document: BenchChem. \[Structural Modifications of Camptothecin for Improved Efficacy: A Technical Guide\]. BenchChem, \[2026\]. \[Online PDF\]. Available at: \[https://www.benchchem.com/product/b12381055/docs#structural-modifications-of-camptothecin-for-improved-efficacy-a-technical-guide\]](#)

---

#### Disclaimer & Data Validity:

The information provided in this document is for Research Use Only (RUO) and is strictly not intended for diagnostic or therapeutic procedures. While BenchChem strives to provide accurate protocols, we make no warranties, express or implied, regarding the fitness of this product for every specific experimental setup.

**Technical Support:** The protocols provided are for reference purposes. Unsure if this reagent suits your experiment?

**Need Industrial/Bulk Grade?** [Request Custom Synthesis Quote](#)

## BenchChem

Our mission is to be the trusted global source of essential and advanced chemicals, empowering scientists and researchers to drive progress in science and industry.

#### Contact

Address: 3281 E Guasti Rd

Ontario, CA 91761, United States

Phone: (601) 213-4426

Email: [info@benchchem.com](mailto:info@benchchem.com)

Contact our Ph.D. Support Team for a compatibility check