

Replicating Key Experiments with Gaba-IN-1: A Comparative Guide

Author: BenchChem Technical Support Team. **Date:** April 2026

Compound of Interest

Compound Name: *Gaba-IN-1*

Cat. No.: *B12381740*

[Get Quote](#)

For Researchers, Scientists, and Drug Development Professionals

This guide provides a comparative analysis of **Gaba-IN-1**, an insecticidal GABA inhibitor. Due to the limited availability of detailed scientific literature and experimental data for **Gaba-IN-1**, this document focuses on providing a comprehensive overview of a well-characterized alternative with a similar mechanism of action: Fipronil.

Fipronil is a widely studied phenylpyrazole insecticide that acts as a non-competitive antagonist of the GABA receptor in insects.^[1] This guide will detail key experiments involving Fipronil, compare its performance with other relevant compounds, and provide the necessary protocols to replicate these studies.

Comparison of Insecticidal Efficacy

The following table summarizes the insecticidal activity of Fipronil and other non-competitive antagonists of the insect GABA receptor.

Compound	Insect Species	Assay Type	Efficacy Metric (Concentration /Dose)	Source(s)
Fipronil	Housefly (<i>Musca domestica</i>)	Topical Application	LD ₅₀ : 0.28 µg/g	[2]
Dieldrin	Housefly (<i>Musca domestica</i>)	Topical Application	LD ₅₀ : 0.8 µg/g	[3]
Picrotoxin	Cockroach (<i>Periplaneta americana</i>)	Injection	Convulsive Dose: ~10 ⁻⁶ M	[4]
Gaba-IN-1	Not Specified (Larvae)	Not Specified	93% mortality at 50 mg/L	Commercial Data

Key Experimental Protocols

Radioligand Binding Assay for GABA Receptor

This protocol is used to determine the binding affinity of a compound to the insect GABA receptor.

Objective: To quantify the inhibitory constant (K_i) of a test compound for the binding of a radiolabeled ligand (e.g., [³H]EBOB) to insect neuronal membranes.

Materials:

- Insect neuronal membranes (e.g., from housefly heads)
- Radioligand: [³H]ethynylbicycloorthobenzoate ([³H]EBOB)
- Test compounds (Fipronil, Dieldrin, etc.)
- Incubation buffer (e.g., 50 mM Tris-HCl, pH 7.4, containing 200 mM NaCl)
- Scintillation cocktail
- Glass fiber filters

- Filtration apparatus
- Scintillation counter

Procedure:

- Prepare insect neuronal membranes by homogenization and centrifugation.
- In a series of tubes, add a fixed concentration of [³H]EBOB and varying concentrations of the test compound to the membrane preparation.
- Incubate the mixture at a specific temperature (e.g., 25°C) for a set duration (e.g., 90 minutes) to reach equilibrium.
- Terminate the binding reaction by rapid filtration through glass fiber filters.
- Wash the filters with ice-cold incubation buffer to remove unbound radioligand.
- Place the filters in scintillation vials with scintillation cocktail.
- Quantify the radioactivity using a scintillation counter.
- Analyze the data to determine the IC₅₀ (concentration of test compound that inhibits 50% of specific radioligand binding) and calculate the K_i value.^[5]

Electrophysiological Recording of GABA-gated Chloride Currents

This protocol measures the effect of a compound on the function of the GABA receptor using the two-electrode voltage-clamp technique in *Xenopus* oocytes expressing the insect GABA receptor.

Objective: To determine if a test compound acts as an antagonist of the GABA-gated chloride channel and to quantify its inhibitory effect.

Materials:

- *Xenopus laevis* oocytes

- cRNA encoding the insect GABA receptor subunit (e.g., *Drosophila* RDL)
- Two-electrode voltage-clamp setup
- Recording solution (e.g., ND96)
- GABA solution
- Test compound solutions (Fipronil, Picrotoxin, etc.)
- Microinjection setup

Procedure:

- Inject the cRNA encoding the insect GABA receptor into *Xenopus* oocytes.
- Incubate the oocytes for 2-5 days to allow for receptor expression.
- Place an oocyte in the recording chamber and impale it with two electrodes (voltage and current).
- Clamp the oocyte membrane potential at a holding potential (e.g., -80 mV).
- Apply GABA to the oocyte to elicit an inward chloride current.
- After washing out the GABA, pre-apply the test compound for a set duration.
- Co-apply GABA and the test compound and record the resulting current.
- Compare the current amplitude in the presence and absence of the test compound to determine the degree of inhibition.[\[6\]](#)[\[7\]](#)
- Construct a concentration-response curve to determine the IC_{50} of the test compound.

Signaling Pathways and Experimental Workflows

The following diagrams illustrate the GABAergic signaling pathway targeted by these insecticides and the general workflow for their evaluation.

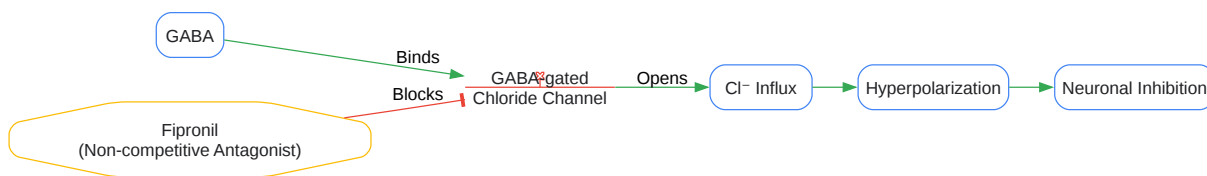

[Click to download full resolution via product page](#)

GABAergic Signaling Pathway and Fipronil's Site of Action.

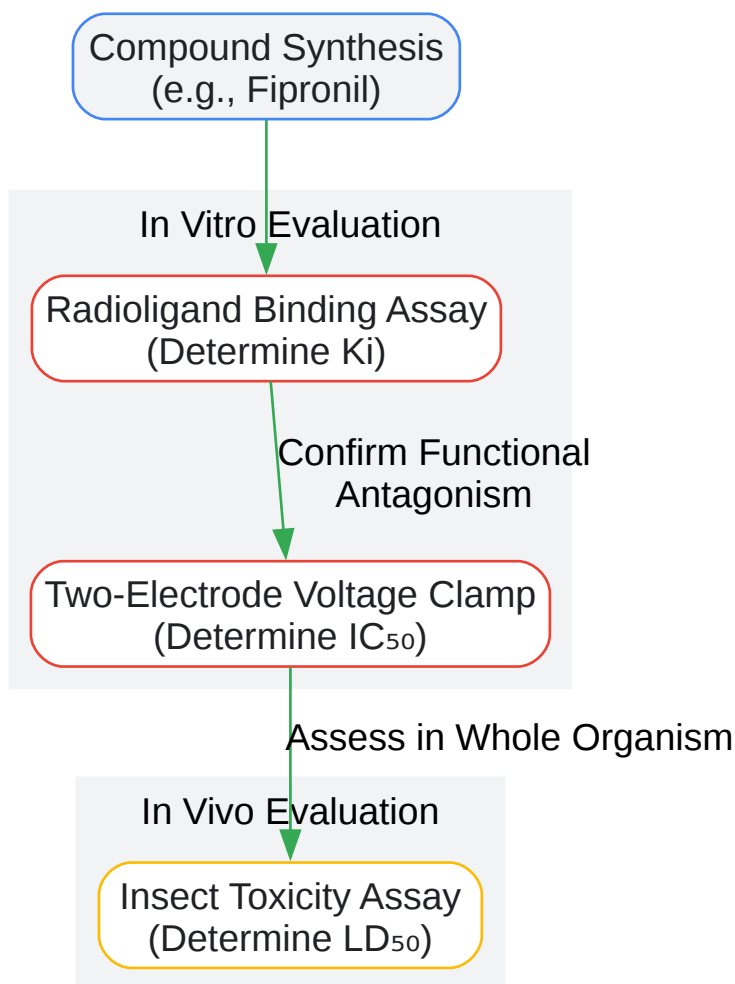

[Click to download full resolution via product page](#)

General Experimental Workflow for Evaluating GABA Receptor Antagonists.

Need Custom Synthesis?

BenchChem offers custom synthesis for rare earth carbides and specific isotopic labeling.

Email: info@benchchem.com or [Request Quote Online](#).

References

- [1. Fipronil - Wikipedia \[en.wikipedia.org\]](#)
- [2. Fipronil insecticide: Novel photochemical desulfinylation with retention of neurotoxicity - PMC \[pmc.ncbi.nlm.nih.gov\]](#)
- [3. Studies on the metabolism, mode of action, and development of insecticides acting on the GABA receptor \[jstage.jst.go.jp\]](#)
- [4. Blocking actions of picrotoxinin analogues on insect \(Periplaneta americana\) GABA receptors - PubMed \[pubmed.ncbi.nlm.nih.gov\]](#)
- [5. GABA receptor subunit composition relative to insecticide potency and selectivity - PubMed \[pubmed.ncbi.nlm.nih.gov\]](#)
- [6. Electrophysiological analysis of synaptic transmission in central neurons of Drosophila larvae - PubMed \[pubmed.ncbi.nlm.nih.gov\]](#)
- [7. biorxiv.org \[biorxiv.org\]](#)
- To cite this document: BenchChem. [Replicating Key Experiments with Gaba-IN-1: A Comparative Guide]. BenchChem, [2026]. [Online PDF]. Available at: [\[https://www.benchchem.com/product/b12381740/docs#replicating-key-experiments-with-gaba-in-1-a-comparative-guide\]](https://www.benchchem.com/product/b12381740/docs#replicating-key-experiments-with-gaba-in-1-a-comparative-guide)

Disclaimer & Data Validity:

The information provided in this document is for Research Use Only (RUO) and is strictly not intended for diagnostic or therapeutic procedures. While BenchChem strives to provide accurate protocols, we make no warranties, express or implied, regarding the fitness of this product for every specific experimental setup.

Technical Support: The protocols provided are for reference purposes. Unsure if this reagent suits your experiment?

Need Industrial/Bulk Grade? [Request Custom Synthesis Quote](#)

BenchChem

Our mission is to be the trusted global source of essential and advanced chemicals, empowering scientists and researchers to drive progress in science and industry.

Contact

Address: 3281 E Guasti Rd
Ontario, CA 91761, United States
Phone: (601) 213-4426
Email: info@benchchem.com

[Contact our Ph.D. Support Team for a compatibility check](#)