

G-Subtide in Neuroscience Research: A Technical Guide

Author: BenchChem Technical Support Team. **Date:** April 2026

Compound of Interest

Compound Name: G-Subtide
Cat. No.: B12381238

[Get Quote](#)

Audience: Researchers, scientists, and drug development professionals.

Core Focus: This document provides an in-depth technical overview of **G-Subtide**, a key synthetic peptide substrate used in neuroscience research to investigate critical signaling pathways. It details its mechanism of action, experimental applications, and relevance in drug discovery.

Introduction to G-Subtide

G-Subtide is a synthetic peptide derived from a G-substrate protein originally localized in the Purkinje cells of the cerebellum.^[1] Its specific amino acid sequence makes it an effective substrate for several key serine/threonine kinases, most notably cGMP-dependent protein kinase (PKG) and Protein Kinase C (PKC).^{[1][2]} This property allows researchers to probe the activity of these enzymes, which are central components of intracellular signaling cascades vital for neuronal function, plasticity, and response to stimuli. Understanding these pathways is crucial for dissecting the molecular underpinnings of synaptic transmission, memory formation, and various neuropathologies.

The primary sequence of **G-Subtide** is designed to be recognized and phosphorylated by these kinases, making it an invaluable tool for in vitro kinase assays, high-throughput screening

for kinase modulators, and studying the complex cross-talk between different signaling pathways.[3][4]

Physicochemical and Technical Properties

G-Subtide is a well-characterized peptide with defined properties, making it a reliable reagent for quantitative studies.

Property	Value	Reference
Amino Acid Sequence	Gln-Lys-Arg-Pro-Arg-Arg-Lys-Asp-Thr-Pro	[1]
One-Letter Code	QKRPRRKDTP	[1]
Molecular Formula	C ₅₃ H ₉₆ N ₂₂ O ₁₅	[5]
Molecular Weight	1280.74 g/mol	[5]
Purity	Typically >95%	[5]
Format	Lyophilized powder	[5]
Storage Conditions	Store at -20°C for long-term stability	[5]

Mechanism of Action and Associated Signaling Pathways

G-Subtide functions as a phosphate acceptor for kinases involved in G-protein coupled receptor (GPCR) signaling. GPCRs are a vast family of transmembrane receptors that detect molecules outside the cell and activate internal signal transduction pathways, ultimately leading to cellular responses. The activation of these pathways often involves heterotrimeric G-proteins, which dissociate into G α and G $\beta\gamma$ subunits to modulate downstream effectors. **G-Subtide** is particularly relevant for studying the Gq and Gs pathways.

The Gq/Phospholipase C/PKC Pathway

The Gq pathway is critical for regulating intracellular calcium levels and various cellular processes through the activation of Protein Kinase C (PKC). When a ligand binds to a Gq-coupled GPCR, the Gαq subunit activates the enzyme Phospholipase C (PLC). PLC cleaves phosphatidylinositol 4,5-bisphosphate (PIP₂) into two second messengers: inositol trisphosphate (IP₃) and diacylglycerol (DAG). DAG, in conjunction with Ca²⁺ released from the endoplasmic reticulum via IP₃-gated channels, activates PKC. Activated PKC then phosphorylates target substrates, such as **G-Subtide**, on serine or threonine residues, modulating their activity and propagating the signal.

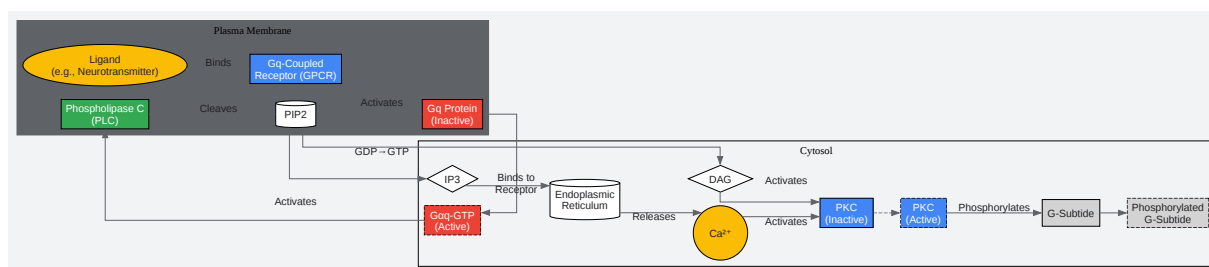

[Click to download full resolution via product page](#)

Caption: The Gq-protein signaling cascade leading to the activation of PKC and phosphorylation of **G-Subtide**.

The Gs/Adenylyl Cyclase/PKA Pathway

In the Gs pathway, ligand binding to a Gs-coupled GPCR leads to the activation of the G α s subunit. This active subunit stimulates adenylyl cyclase, an enzyme that converts ATP into the second messenger cyclic AMP (cAMP). Elevated cAMP levels activate Protein Kinase A (PKA). PKA is another serine/threonine kinase that phosphorylates a wide range of cellular proteins, including peptides with recognition sequences similar to that of **G-Subtide**, thereby regulating diverse neuronal functions.

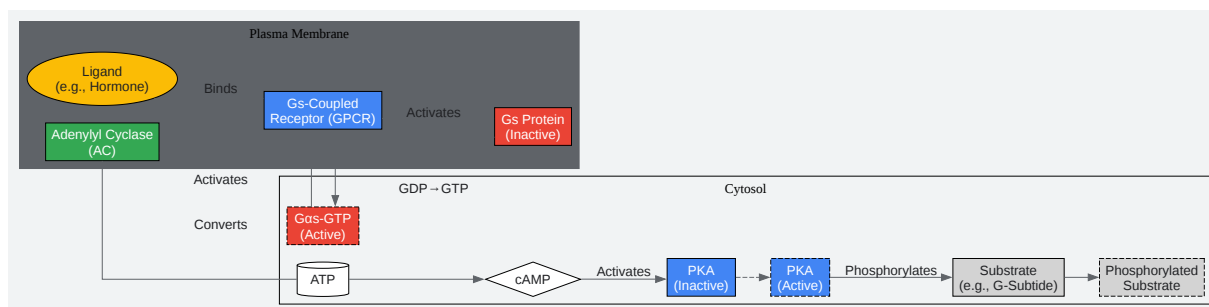

[Click to download full resolution via product page](#)

Caption: The Gs-protein signaling cascade resulting in the activation of PKA and substrate phosphorylation.

Quantitative Kinase Activity Data

The efficiency of a kinase in phosphorylating a substrate is determined by its kinetic parameters, Michaelis constant (K_m) and maximum velocity (V_{max}). K_m represents the substrate concentration at which the reaction rate is half of V_{max} and is an inverse measure of the substrate's affinity for the enzyme. While specific kinetic data for **G-Subtide** is sparsely

reported in publicly available literature, the table below presents representative kinetic values for similar synthetic peptide substrates for PKC to illustrate the typical range of these parameters. These values are crucial for designing experiments and for the quantitative comparison of kinase activity under different conditions.

Kinase Isozyme	Peptide Substrate	K_m (μM)	Relative V_{max} (%)	Reference
PKC α	Ac-MBP(4-14)	7.2	100	[1]
PKC β I	Ac-MBP(4-14)	6.5	95	[1]
PKC γ	Ac-MBP(4-14)	8.1	110	[1]
PKA	Kemptide	16	100	N/A

Note: Data for PKC is derived from studies on Myelin Basic Protein fragment peptides, which are common PKC substrates. Data for PKA is for its well-known substrate Kemptide. These values are for illustrative purposes to provide context for the expected kinetic parameters in kinase assays.

Experimental Protocol: In Vitro Kinase Assay

This protocol outlines a standard procedure for measuring the activity of PKC using **G-Subtide** as a substrate. This type of assay is fundamental for screening potential kinase inhibitors or activators.

5.1 Materials and Reagents

- Purified, active Protein Kinase C (PKC)
- **G-Subtide** peptide
- Kinase Buffer (e.g., 20 mM HEPES pH 7.4, 10 mM MgCl₂, 1 mM DTT)
- ATP (stock solution, e.g., 10 mM)
- [γ -³²P]ATP (radioisotope) or a fluorescence-based detection system (e.g., ADP-Glo™)

- Phosphatidylserine (PS) and Diacylglycerol (DAG) for PKC activation
- 96-well microplates
- Phosphocellulose paper (for radioactive assays)
- Scintillation counter and fluid (for radioactive assays)
- Luminometer (for ADP-Glo™ assay)
- Stop Solution (e.g., 75 mM phosphoric acid for radioactive assay)

5.2 Procedure

- Prepare Kinase Reaction Master Mix: In a microcentrifuge tube on ice, prepare a master mix containing the kinase buffer, activators (PS/DAG), and the purified PKC enzyme. The final concentration of each component should be calculated based on the total reaction volume.
- Prepare Substrate/ATP Mix: In a separate tube, prepare a mix of **G-Subtide** and ATP. For radioactive assays, spike the 'cold' ATP with [γ -³²P]ATP. The final concentration of **G-Subtide** should be near its K_m (if known, otherwise empirically determined, e.g., 10-50 μ M), and ATP should be at a saturating concentration (e.g., 100 μ M).
- Initiate Reaction: Add the Kinase Reaction Master Mix to the wells of a 96-well plate. To initiate the phosphorylation reaction, add the Substrate/ATP mix to each well. The typical final reaction volume is 25-50 μ L.
- Incubation: Incubate the plate at 30°C for a predetermined time (e.g., 10-30 minutes), ensuring the reaction is within the linear range.
- Terminate Reaction:
 - Radioactive Assay: Stop the reaction by adding Stop Solution. Spot a portion of the reaction mixture onto phosphocellulose paper. Wash the paper extensively (e.g., 3-4 times in 0.75% phosphoric acid) to remove unincorporated [γ -³²P]ATP. Air dry the paper and measure the incorporated radioactivity using a scintillation counter.

- Luminescence Assay (ADP-Glo™): Add the ADP-Glo™ Reagent to terminate the kinase reaction and deplete the remaining ATP. Then, add the Kinase Detection Reagent to convert the newly formed ADP back to ATP, which is then used by a luciferase to generate a luminescent signal proportional to the ADP produced. Read the luminescence on a plate-reading luminometer.
- Data Analysis: Quantify the amount of phosphorylated **G-Subtide** (or ADP produced) by comparing it to controls (e.g., no enzyme, no substrate). When screening compounds, calculate the percent inhibition relative to a vehicle control.

Visualized Experimental Workflow

The following diagram illustrates the key steps in a typical in vitro kinase assay designed for screening potential inhibitors.

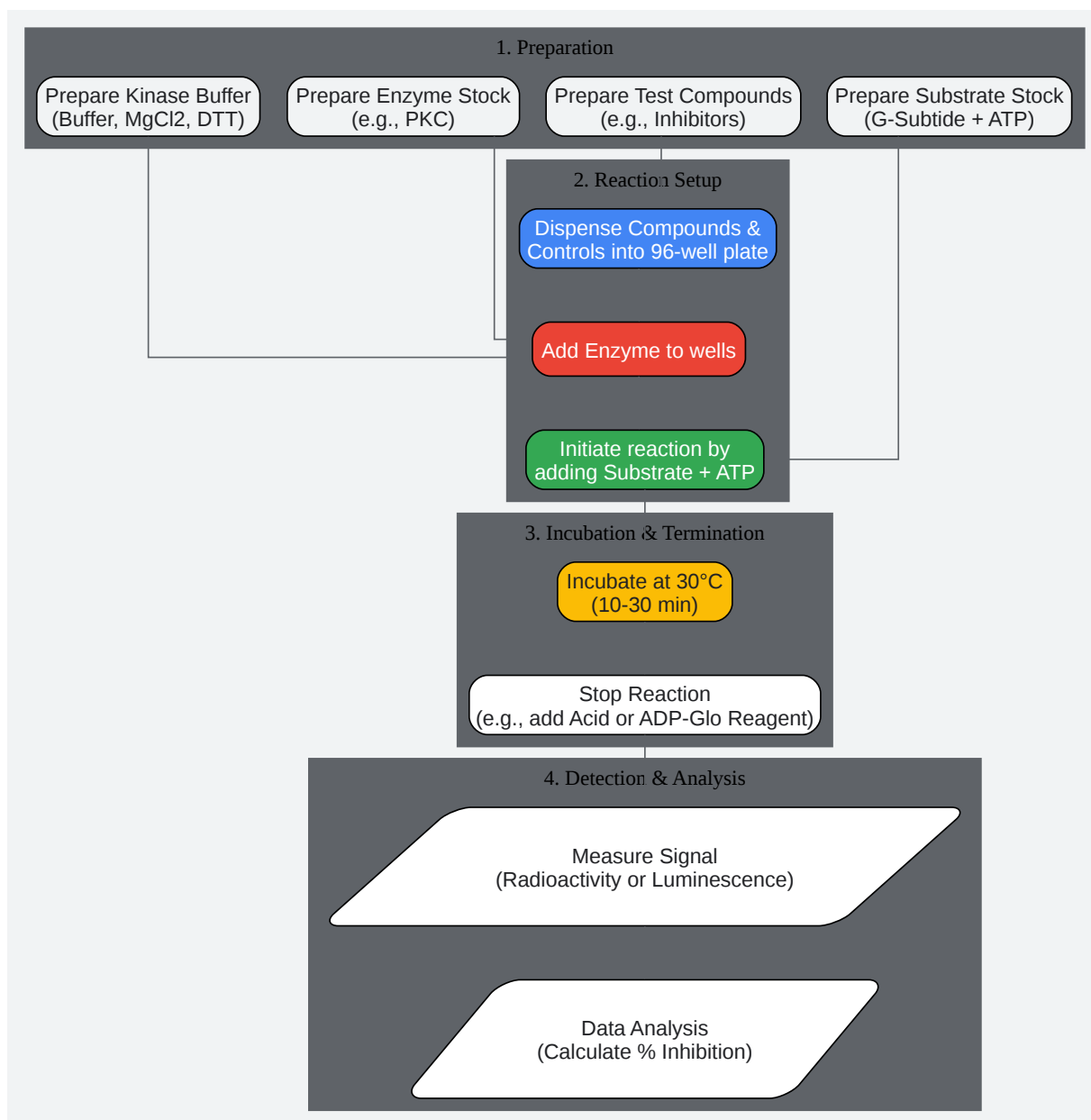

[Click to download full resolution via product page](#)

Caption: A generalized workflow for an in vitro kinase inhibition assay using **G-Subtide** as a substrate.

Applications in Neuroscience Drug Discovery

The study of kinase signaling pathways is paramount in drug discovery for neurological disorders. Dysregulation of PKC and PKA activity is implicated in conditions ranging from Alzheimer's disease to chronic pain and psychiatric disorders.

- **High-Throughput Screening (HTS):** **G-Subtide** is an ideal reagent for HTS campaigns to identify novel kinase inhibitors or activators. The robustness and reproducibility of assays using **G-Subtide** allow for the screening of large compound libraries to find potential therapeutic leads.
- **Target Validation:** By providing a means to quantify the activity of specific kinases, **G-Subtide** helps validate these enzymes as viable drug targets for a particular disease state.
- **Specificity Profiling:** **G-Subtide** can be used in panels with other substrates to profile the specificity of a lead compound against a range of different kinases, which is a critical step in preclinical drug development to minimize off-target effects.

Conclusion

G-Subtide is a powerful and versatile tool in neuroscience research. Its well-defined sequence and properties make it a standard substrate for studying the activity of crucial signaling kinases like PKC and PKG. By enabling the detailed investigation of G-protein signaling cascades and providing a robust platform for drug screening, **G-Subtide** continues to be instrumental in advancing our understanding of neuronal function and in the development of novel therapeutics for neurological diseases.

Need Custom Synthesis?

BenchChem offers custom synthesis for rare earth carbides and specific isotopic labeling.

Email: info@benchchem.com or [Request Quote Online](#).

References

- [1. Substrate specificity of protein kinase C. Use of synthetic peptides corresponding to physiological sites as probes for substrate recognition requirements - PubMed \[pubmed.ncbi.nlm.nih.gov\]](#)
- [2. Kinetic diversity in G-protein-coupled receptor signalling - PMC \[pmc.ncbi.nlm.nih.gov\]](#)
- [3. researchgate.net \[researchgate.net\]](#)
- [4. researchgate.net \[researchgate.net\]](#)
- [5. G-protein-coupled receptor phosphorylation: where, when and by whom - PMC \[pmc.ncbi.nlm.nih.gov\]](#)
- [To cite this document: BenchChem. \[G-Subtide in Neuroscience Research: A Technical Guide\]. BenchChem, \[2026\]. \[Online PDF\]. Available at: \[https://www.benchchem.com/product/b12381238/docs#g-subtide-in-neuroscience-research-a-technical-guide\]](#)

Disclaimer & Data Validity:

The information provided in this document is for Research Use Only (RUO) and is strictly not intended for diagnostic or therapeutic procedures. While BenchChem strives to provide accurate protocols, we make no warranties, express or implied, regarding the fitness of this product for every specific experimental setup.

Technical Support: The protocols provided are for reference purposes. Unsure if this reagent suits your experiment?

Need Industrial/Bulk Grade? [Request Custom Synthesis Quote](#)

BenchChem

Our mission is to be the trusted global source of essential and advanced chemicals, empowering scientists and researchers to drive progress in science and industry.

Contact

Address: 3281 E Guasti Rd

Ontario, CA 91761, United States

Phone: (601) 213-4426

Email: info@benchchem.com

Contact our Ph.D. Support Team for a compatibility check