

Comparative Analysis of Mortalin Bioassays and Inhibitors

Author: BenchChem Technical Support Team. **Date:** April 2026

Compound of Interest

Compound Name: *Mortatarin F*

Cat. No.: *B12381590*

[Get Quote](#)

This guide provides a comparative overview of bioassays related to the chaperone protein Mortalin (also known as GRP75 or HSPA9) and its inhibitors. Mortalin is a key regulator in various cellular processes, including protein folding, mitochondrial biogenesis, and stress response.^{[1][2][3]} Its overexpression is implicated in several cancers, making it a significant therapeutic target.^{[4][5][6]} This document is intended for researchers, scientists, and drug development professionals interested in the study of Mortalin and the evaluation of its inhibitors.

Quantitative Data Summary of Mortalin Inhibitors

The following table summarizes the effects of various Mortalin inhibitors based on experimental data from published studies. These compounds represent different classes of molecules that interfere with Mortalin's function through various mechanisms.

Inhibitor	Target Interaction/ Mechanism	Cell Line(s)	IC50 Value	Key Bioassay Findings	Reference
Mortaparib	Binds to Mortalin, abrogates Mortalin-p53 interaction, and inhibits PARP-1.[4][5]	Breast cancer cells	Not specified	Induces nuclear translocation of p53, leading to apoptosis and cell cycle arrest.[4] Downregulate s proteins involved in cell migration. [4]	[4][5]
MKT-077	Binds to the ATPase domain of Hsp70 family proteins, including Mortalin.[7][8]	Pancreatic ductal adenocarcinoma (PDAC) cells (MIA-PaCa-2, AsPC-1, PANC-1)	~2.5-5 μ M	Selectively induces cell death in KRAS-mutated cells. [8]	[8]
JG-98 (MKT-077 derivative)	Improved affinity and selectivity for the Hsp70 binding pocket compared to MKT-077.[8]	PDAC cells (MIA PaCa-2, AsPC-1), HCT116	Lower than MKT-077	Higher potency in inducing cell death in KRAS-mutated cells compared to MKT-077.[8]	[8]
Apoptozole-TPP	Inhibits the ATPase activity of	Tumor cells	Not specified	Induces apoptosis by inhibiting	[4]

Conjugate (Az-TPP-O3)	mitochondrial Mortalin.[4]			Mortalin's ATPase function.[4]	
Fucoxanthin	Natural carotenoid that downregulate s Mortalin expression.	Not specified	Not specified	Induces G0- G1 phase growth arrest and apoptosis.[4]	[4]
Mycalin A	Binds to Mortalin, disrupting the Mortalin-p53 complex.[9]	HeLa, A375, MCF7	Not specified	Increases p53 transcriptiona l activity, leading to cell cycle arrest and apoptosis.[9]	[9]

Experimental Protocols

Detailed methodologies for key experiments cited in the study of Mortalin and its inhibitors are provided below.

Co-Immunoprecipitation (Co-IP) for Mortalin-p53 Interaction

This assay is used to determine if two proteins, in this case Mortalin and p53, are bound to each other within a cell.

- **Cell Lysis:** Culture and treat cells with the test compound (e.g., Mortaparib). Lyse the cells in a non-denaturing lysis buffer containing protease inhibitors to maintain protein-protein interactions.
- **Antibody Incubation:** Add an antibody specific to one of the proteins of interest (e.g., anti-Mortalin antibody) to the cell lysate. Incubate to allow the antibody to bind to its target protein.

- Immunoprecipitation: Add protein A/G-agarose beads to the lysate. These beads bind to the antibody, which is in turn bound to its target protein and any associated proteins.
- Washing: Pellet the beads by centrifugation and wash several times with lysis buffer to remove non-specifically bound proteins.
- Elution and Western Blotting: Elute the protein complexes from the beads. Separate the proteins by SDS-PAGE, transfer to a membrane, and probe with an antibody against the second protein of interest (e.g., anti-p53 antibody) to detect the interaction.

Cell Viability/Cytotoxicity Assay (IC50 Determination)

This assay measures the concentration of a compound required to inhibit the growth of 50% of a cell population.

- Cell Seeding: Plate cells in a 96-well plate at a predetermined density and allow them to adhere overnight.
- Compound Treatment: Treat the cells with a serial dilution of the test compound (e.g., MKT-077, JG-98) for a specified period (e.g., 72 hours).
- Viability Reagent: Add a viability reagent such as MTT or resazurin. Viable cells will metabolize these reagents, resulting in a colorimetric or fluorescent signal.
- Signal Quantification: Measure the signal using a microplate reader.
- Data Analysis: Plot the percentage of viable cells against the compound concentration and fit a dose-response curve to calculate the IC50 value.

ATPase Activity Assay

This assay measures the rate at which Mortalin hydrolyzes ATP, a key aspect of its chaperone function.

- Reaction Setup: Prepare a reaction mixture containing purified recombinant Mortalin, ATP, and a buffer that mimics physiological conditions.
- Compound Addition: Add the test inhibitor (e.g., Az-TPP-O3) at various concentrations.

- Incubation: Incubate the reaction at 37°C for a set period.
- Phosphate Detection: Stop the reaction and measure the amount of inorganic phosphate (Pi) released using a colorimetric method, such as the PiColorLock assay. The amount of Pi is proportional to the ATPase activity.
- Data Analysis: Compare the ATPase activity in the presence of the inhibitor to a control without the inhibitor to determine the extent of inhibition.

Visualizations

Mortalin-p53 Signaling Pathway and its Inhibition

The following diagram illustrates the interaction between Mortalin and the tumor suppressor protein p53, a key pathway in cancer development, and how Mortalin inhibitors can disrupt this interaction to restore p53 function.

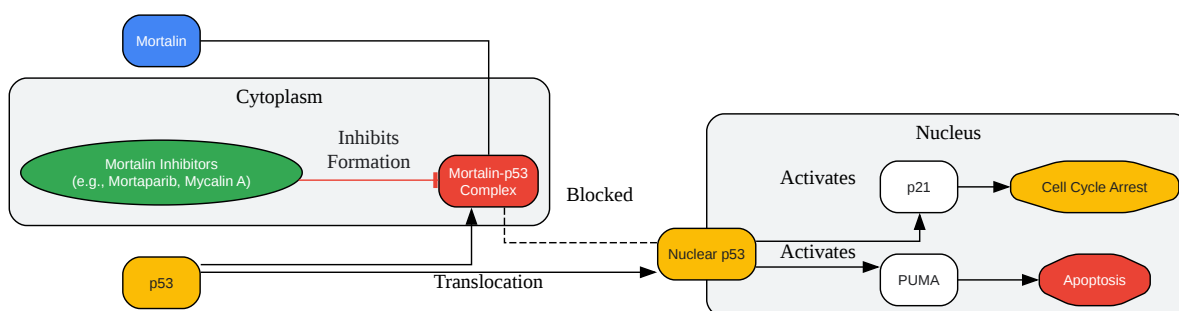

[Click to download full resolution via product page](#)

Caption: Mortalin sequesters p53 in the cytoplasm, preventing its tumor suppressor function.

Experimental Workflow for Co-Immunoprecipitation

The diagram below outlines the key steps in a co-immunoprecipitation experiment to study the interaction between Mortalin and p53.

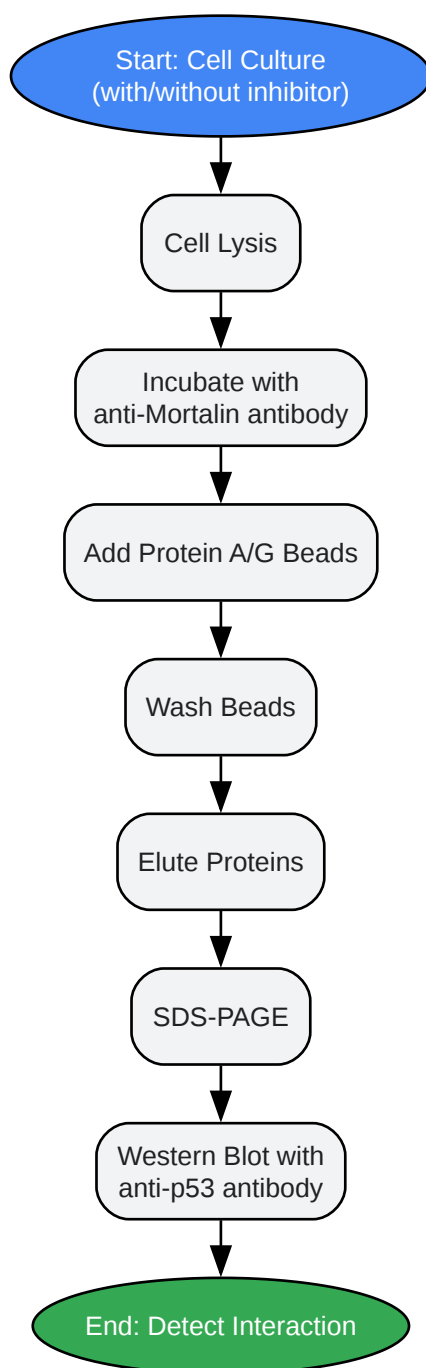

[Click to download full resolution via product page](#)

Caption: Workflow for detecting the Mortalin-p53 protein-protein interaction.

Need Custom Synthesis?

BenchChem offers custom synthesis for rare earth carbides and specific isotopic labeling.

Email: info@benchchem.com or [Request Quote Online](#).

References

- 1. [Frontiers | Mortalin: Protein partners, biological impacts, pathological roles, and therapeutic opportunities \[frontiersin.org\]](#)
- 2. [Mortalin, Apoptosis, and Neurodegeneration - PMC \[pmc.ncbi.nlm.nih.gov\]](#)
- 3. [Mortalin - a multipotent chaperone regulating cellular processes ranging from viral infection to neurodegeneration - PubMed \[pubmed.ncbi.nlm.nih.gov\]](#)
- 4. [Synthetic and Natural Inhibitors of Mortalin for Cancer Therapy - PMC \[pmc.ncbi.nlm.nih.gov\]](#)
- 5. [Frontiers | Why is Mortalin a Potential Therapeutic Target for Cancer? \[frontiersin.org\]](#)
- 6. [mdpi.com \[mdpi.com\]](#)
- 7. [Frontiers | Abrogating the Interaction Between p53 and Mortalin \(Grp75/HSPA9/mtHsp70\) for Cancer Therapy: The Story so far \[frontiersin.org\]](#)
- 8. [Mortalin/HSPA9 targeting selectively induces KRAS tumor cell death by perturbing mitochondrial membrane permeability - PMC \[pmc.ncbi.nlm.nih.gov\]](#)
- 9. [Identification of Mortalin as the Main Interactor of Mycalin A, a Poly-Brominated C-15 Acetogenin Sponge Metabolite, by MS-Based Proteomics \[mdpi.com\]](#)
- To cite this document: BenchChem. [Comparative Analysis of Mortalin Bioassays and Inhibitors]. BenchChem, [2026]. [Online PDF]. Available at: [\[https://www.benchchem.com/product/b12381590/docs#comparative-analysis-of-mortalin-bioassays-and-inhibitors\]](https://www.benchchem.com/product/b12381590/docs#comparative-analysis-of-mortalin-bioassays-and-inhibitors)

Disclaimer & Data Validity:

The information provided in this document is for Research Use Only (RUO) and is strictly not intended for diagnostic or therapeutic procedures. While BenchChem strives to provide accurate protocols, we make no warranties, express or implied, regarding the fitness of this product for every specific experimental setup.

Technical Support: The protocols provided are for reference purposes. Unsure if this reagent suits your experiment?

Need Industrial/Bulk Grade? [Request Custom Synthesis Quote](#)

BenchChem

Our mission is to be the trusted global source of essential and advanced chemicals, empowering scientists and researchers to drive progress in science and industry.

Contact

Address: 3281 E Guasti Rd

Ontario, CA 91761, United States

Phone: (601) 213-4426

Email: info@benchchem.com

[Contact our Ph.D. Support Team for a compatibility check](#)