

# Comparative Analysis of GABAergic Modulators: A Guide for Researchers

**Author:** BenchChem Technical Support Team. **Date:** April 2026

## Compound of Interest

Compound Name: *Gaba-IN-1*  
Cat. No.: *B12381740*

[Get Quote](#)

In the realm of neuroscience and drug development, understanding the nuanced differences between various GABAergic modulators is paramount for designing targeted therapeutics. This guide provides a comparative analysis of key classes of positive allosteric modulators (PAMs) of the  $\gamma$ -aminobutyric acid type A (GABA-A) receptor. While the initial query focused on a compound designated "**Gaba-IN-1**," an extensive search of the scientific literature did not yield any information on a molecule with this identifier. Therefore, this guide will focus on a comparative analysis of three well-characterized and clinically significant GABAergic modulators: Diazepam, a classic benzodiazepine; Zolpidem, a non-benzodiazepine hypnotic (Z-drug); and Propofol, an intravenous general anesthetic.

This comparison will delve into their mechanisms of action, quantitative pharmacological parameters, and the experimental protocols used to characterize them, providing a valuable resource for researchers, scientists, and drug development professionals.

## Mechanism of Action and Receptor Subtype Selectivity

GABA-A receptors are the primary mediators of fast inhibitory neurotransmission in the central nervous system.[1][2] These receptors are pentameric ligand-gated ion channels, and their

activation by GABA leads to an influx of chloride ions, hyperpolarizing the neuron and thus reducing its excitability.[1][3] Positive allosteric modulators enhance the effect of GABA without directly activating the receptor themselves.[4] However, the precise mechanism and binding sites differ between modulator classes, leading to distinct pharmacological profiles.

Diazepam, as a benzodiazepine, binds to the interface between the  $\alpha$  and  $\gamma$  subunits of the GABA-A receptor.[4][5] This binding increases the frequency of channel opening in the presence of GABA, thereby potentiating the inhibitory signal.[6] Benzodiazepines like diazepam exhibit broad activity across various GABA-A receptor subtypes containing  $\alpha 1$ ,  $\alpha 2$ ,  $\alpha 3$ , and  $\alpha 5$  subunits.[7]

Zolpidem, a Z-drug, also binds to the benzodiazepine site on the GABA-A receptor but displays a high affinity for receptors containing the  $\alpha 1$  subunit.[8][9] This  $\alpha 1$ -selectivity is thought to be responsible for its potent hypnotic effects with less anxiolytic and myorelaxant properties compared to non-selective benzodiazepines.[8]

Propofol, a general anesthetic, is believed to bind to a distinct site in the transmembrane domain of the GABA-A receptor, at the interface between the  $\beta$  and  $\alpha$  subunits.[5] Unlike benzodiazepines, propofol increases the duration of channel opening and, at higher concentrations, can directly activate the GABA-A receptor, contributing to its profound anesthetic effects.[10]

## Quantitative Comparison of GABAergic Modulators

The following table summarizes key quantitative data for Diazepam, Zolpidem, and Propofol, providing a basis for comparing their potency and efficacy at the GABA-A receptor.

Parameter	Diazepam	Zolpidem	Propofol
Binding Affinity (K <sub>i</sub> )	~4 nM (human cortex)	~20 nM (α1β2γ2)	~0.5 μM (potentiating concentration)
Potency (EC <sub>50</sub> )	Varies by subtype and assay	~230 nM (for γ2-containing receptors)	Varies, potentiates GABA at ~0.5 μM
Efficacy (% of max GABA response)	Potentiates GABA response	Potentiates GABA response	Potentiates and directly activates
Receptor Subtype Selectivity	α1, α2, α3, α5	α1 > α2, α3	β-subunit dependent

Note: The values presented are approximate and can vary depending on the specific GABA-A receptor subunit composition, experimental conditions, and tissue or cell type used.

## Experimental Protocols

The characterization of GABAergic modulators relies on a variety of in vitro and electrophysiological assays. Below are detailed methodologies for two key experiments.

### Radioligand Binding Assay

This assay is used to determine the binding affinity (K<sub>i</sub>) of a compound for a specific receptor.

Objective: To measure the displacement of a radiolabeled ligand from the GABA-A receptor by a test compound.

Materials:

- Rat brain membranes (or cell lines expressing specific GABA-A receptor subtypes)
- [<sup>3</sup>H]muscimol (for the GABA binding site) or [<sup>3</sup>H]flunitrazepam (for the benzodiazepine binding site)
- Test compound (e.g., Diazepam, Zolpidem)
- Binding buffer (e.g., 50 mM Tris-HCl, pH 7.4)

- Wash buffer (e.g., ice-cold 50 mM Tris-HCl, pH 7.4)
- Glass fiber filters
- Scintillation counter

#### Procedure:

- Membrane Preparation: Homogenize rat brains in a homogenization buffer and centrifuge to isolate the membrane fraction. Wash the pellet multiple times to remove endogenous GABA. [1] Resuspend the final pellet in the binding buffer.
- Assay Setup: In a 96-well plate, add the membrane preparation, the radioligand (e.g., 5 nM [<sup>3</sup>H]muscimol), and varying concentrations of the test compound.[1]
- Incubation: Incubate the plate at 4°C for a specified time (e.g., 45 minutes) to allow binding to reach equilibrium.[1]
- Filtration: Terminate the binding reaction by rapid filtration through glass fiber filters using a cell harvester. Wash the filters with ice-cold wash buffer to remove unbound radioligand.
- Quantification: Place the filters in scintillation vials with scintillation fluid and measure the radioactivity using a scintillation counter.
- Data Analysis: Determine the concentration of the test compound that inhibits 50% of the specific binding of the radioligand (IC<sub>50</sub>). Calculate the K<sub>i</sub> value using the Cheng-Prusoff equation.

## Two-Electrode Voltage-Clamp (TEVC) Electrophysiology

This technique is used to measure the effect of a modulator on the function of GABA-A receptors expressed in *Xenopus* oocytes.

Objective: To determine the potency (EC<sub>50</sub>) and efficacy of a modulator in potentiating GABA-evoked currents.

Materials:

- *Xenopus laevis* oocytes
- cRNA encoding the desired GABA-A receptor subunits (e.g.,  $\alpha 1$ ,  $\beta 2$ ,  $\gamma 2$ )
- TEVC setup (amplifier, electrodes, perfusion system)
- Recording solution (e.g., Ba-Ringer's solution)
- GABA solutions of varying concentrations
- Test compound solutions

#### Procedure:

- **Oocyte Preparation and Injection:** Harvest oocytes from a female *Xenopus laevis* frog and inject them with the cRNA encoding the GABA-A receptor subunits. Incubate the oocytes for 2-5 days to allow for receptor expression.
- **Electrophysiological Recording:** Place an oocyte in the recording chamber and impale it with two microelectrodes (one for voltage clamping and one for current recording). Clamp the membrane potential at a holding potential (e.g., -60 mV).
- **GABA Application:** Perfuse the oocyte with a low concentration of GABA (e.g., EC10-EC20) to elicit a baseline current response.
- **Modulator Co-application:** Co-apply the same concentration of GABA with varying concentrations of the test compound and record the potentiated current response.
- **Data Analysis:** Plot the potentiation of the GABA-evoked current as a function of the test compound concentration to determine the EC50 and maximal efficacy.

## Visualizing Pathways and Workflows

To further elucidate the concepts discussed, the following diagrams were generated using the DOT language.

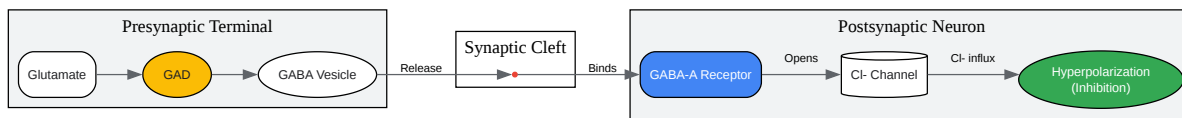

[Click to download full resolution via product page](#)

Caption: GABAergic signaling pathway from synthesis to postsynaptic inhibition.

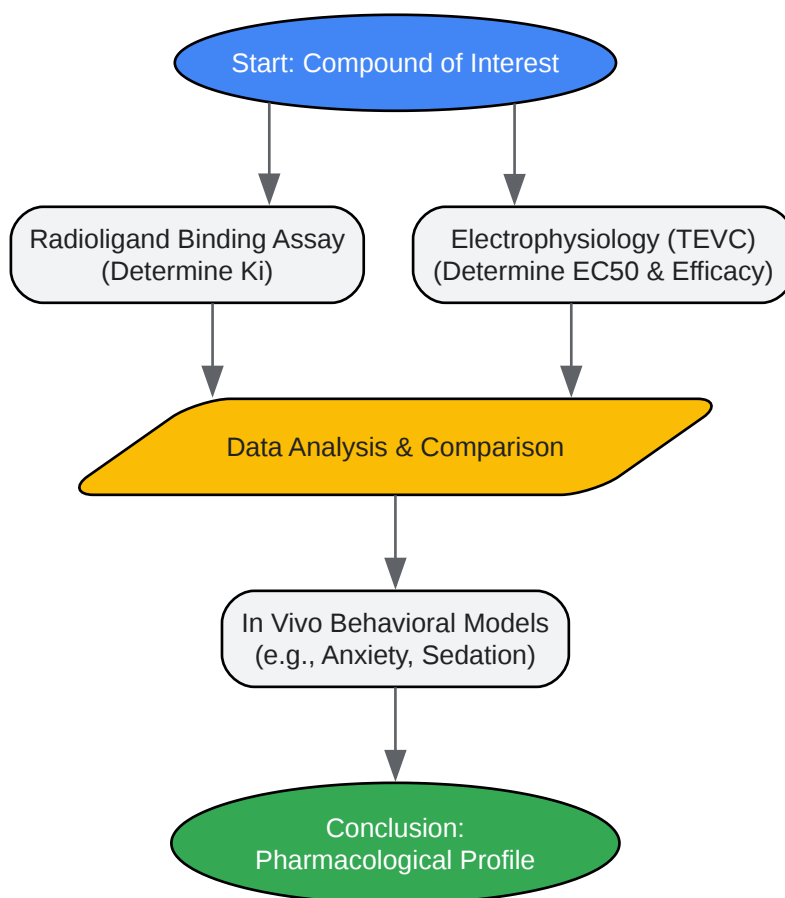

[Click to download full resolution via product page](#)

Caption: Experimental workflow for characterizing GABAergic modulators.

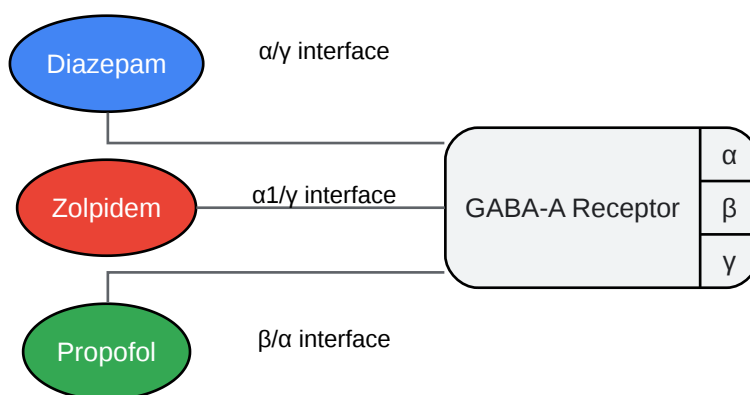

[Click to download full resolution via product page](#)

Caption: Comparison of binding sites for different GABAergic modulators.

## Conclusion

The comparative analysis of Diazepam, Zolpidem, and Propofol highlights the diverse mechanisms by which GABAergic transmission can be modulated. While all three compounds enhance the inhibitory effects of GABA, their distinct binding sites, receptor subtype selectivities, and effects on channel kinetics result in markedly different pharmacological profiles. Diazepam's broad activity makes it an effective anxiolytic and anticonvulsant, Zolpidem's  $\alpha 1$ -selectivity underlies its hypnotic properties, and Propofol's potent and direct effects on the GABA-A receptor are responsible for its anesthetic actions. A thorough understanding of these differences, facilitated by the experimental protocols and data presented in this guide, is crucial for the rational design and development of novel GABAergic modulators with improved therapeutic indices.

### *Need Custom Synthesis?*

BenchChem offers custom synthesis for rare earth carbides and specific isotopic labeling.

Email: [info@benchchem.com](mailto:info@benchchem.com) or [Request Quote Online](#).

## References

- 1. PDSP - GABA [[kidbdev.med.unc.edu](http://kidbdev.med.unc.edu)]
- 2. [pubs.acs.org](http://pubs.acs.org) [[pubs.acs.org](http://pubs.acs.org)]

- [3. A comparison of GABA-ergic \(propofol\) and non-GABA-ergic \(dexmedetomidine\) sedation on visual and motor cortical oscillations, using magnetoencephalography - PMC \[pmc.ncbi.nlm.nih.gov\]](#)
- [4. GABAA receptor positive allosteric modulator - Wikipedia \[en.wikipedia.org\]](#)
- [5. researchgate.net \[researchgate.net\]](#)
- [6. Electrophysiology of ionotropic GABA receptors - PMC \[pmc.ncbi.nlm.nih.gov\]](#)
- [7. droracle.ai \[droracle.ai\]](#)
- [8. Comparison of the effects of zaleplon, zolpidem, and triazolam at various GABA\(A\) receptor subtypes - PubMed \[pubmed.ncbi.nlm.nih.gov\]](#)
- [9. GABAA Receptor  \$\alpha\$  Subunits Differentially Contribute to Diazepam Tolerance after Chronic Treatment - PMC \[pmc.ncbi.nlm.nih.gov\]](#)
- [10. Structural Evidence that Propofol Stabilizes Different GABAA Receptor States at Potentiating and Activating Concentrations - PMC \[pmc.ncbi.nlm.nih.gov\]](#)
- [To cite this document: BenchChem. \[Comparative Analysis of GABAergic Modulators: A Guide for Researchers\]. BenchChem, \[2026\]. \[Online PDF\]. Available at: \[https://www.benchchem.com/product/b12381740/docs#comparative-analysis-of-gabaergic-modulators-a-guide-for-researchers\]](#)

---

### Disclaimer & Data Validity:

The information provided in this document is for Research Use Only (RUO) and is strictly not intended for diagnostic or therapeutic procedures. While BenchChem strives to provide accurate protocols, we make no warranties, express or implied, regarding the fitness of this product for every specific experimental setup.

**Technical Support:** The protocols provided are for reference purposes. Unsure if this reagent suits your experiment?

**Need Industrial/Bulk Grade?** [Request Custom Synthesis Quote](#)

# BenchChem

Our mission is to be the trusted global source of essential and advanced chemicals, empowering scientists and researchers to drive progress in science and industry.

## Contact

Address: 3281 E Guasti Rd

Ontario, CA 91761, United States

Phone: (601) 213-4426

Email: [info@benchchem.com](mailto:info@benchchem.com)

[Contact our Ph.D. Support Team for a compatibility check](#)