

An In-depth Technical Guide to BRI2 Protein: Structure, Function, and Experimental Analysis

Author: BenchChem Technical Support Team. **Date:** April 2026

Compound of Interest

Compound Name: *BrlR2*
Cat. No.: *B12381730*

[Get Quote](#)

For Researchers, Scientists, and Drug Development Professionals

Introduction

The BRI2 protein, also known as Integral Membrane Protein 2B (ITM2B), is a type II transmembrane protein that has garnered significant attention for its emerging roles in neurodegenerative diseases, most notably Alzheimer's disease, as well as the autosomal dominant familial British dementia (FBD) and familial Danish dementia (FDD).[1][2][3] Encoded by the ITM2B gene on chromosome 13, BRI2 is ubiquitously expressed, with particularly high levels in the brain.[1][4] This technical guide provides a comprehensive overview of the current understanding of BRI2's structure, functional domains, and its intricate relationship with cellular signaling pathways. Furthermore, it offers detailed protocols for key experimental procedures essential for advancing research in this field.

BRI2 Protein Structure and Functional Domains

BRI2 is a 266-amino acid protein with a topology characteristic of a type II transmembrane protein, featuring a cytosolic N-terminus, a single transmembrane domain, and a luminal C-terminal ectodomain.[1][5] The protein can be structurally and functionally divided into several key domains, as detailed in the table below.

Quantitative Data on BRI2 Protein Structure

Feature	Description	Amino Acid Residues (Human)	Molecular Weight (kDa)	Reference
Full-Length BRI2	Immature form of the protein.	1-266	~30	[6]
N-terminal Cytosolic Domain	Intracellular region.	1-54	-	[1]
Transmembrane Domain	Single-pass alpha-helical domain.	55-75	-	[1]
Luminal C-terminal Domain	Extracellular region containing the BRICHOS domain.	76-266	-	[1]
BRICHOS Domain	A conserved domain of about 100 amino acids.	137-231	-	[1]
Mature BRI2 (mBRI2)	Product of furin cleavage.	1-243	-	[5]
BRI2-23 Peptide	C-terminal fragment released by furin.	244-266	~3	[1][4]
BRI2-BRICHOS (soluble)	Ectodomain fragment released by ADAM10.	-	~25	[1][4]
BRI2 NTF (membrane-bound)	N-terminal fragment remaining after ADAM10 cleavage.	-	~22	[1][4]

BRI2 ICD	Intracellular domain released by SPPL2a/b.	-	~10	[1][4]
----------	--	---	-----	--------

Proteolytic Processing of BRI2

The function of BRI2 is intricately regulated by a series of proteolytic cleavage events, a process known as regulated intramembrane proteolysis (RIP).[1][4] This processing cascade generates several fragments, each with potential biological activities.

- **Furin Cleavage:** In the trans-Golgi network, the immature BRI2 protein is cleaved by a proprotein convertase, primarily furin, between arginine 243 and glutamic acid 244.[1][5] This releases a 23-amino acid C-terminal peptide (BRI2-23) and generates the mature BRI2 (mBRI2) protein.[5]
- **ADAM10 Cleavage:** The mature BRI2 at the cell surface can be shed by the metalloproteinase ADAM10.[5][6] This cleavage releases the soluble ectodomain containing the BRICHOS domain (BRI2-BRICHOS) into the extracellular space and leaves a membrane-bound N-terminal fragment (BRI2 NTF).[1][5]
- **SPPL2a/b Cleavage:** The BRI2 NTF is subsequently cleaved within its transmembrane domain by signal peptide peptidase-like proteases (SPPL2a and SPPL2b).[1][4] This intramembrane cleavage liberates a small C-terminal fragment into the extracellular space and releases the BRI2 intracellular domain (BRI2 ICD) into the cytoplasm.[1][5]

Signaling Pathway of BRI2 Processing

Caption: Proteolytic processing cascade of the BRI2 protein.

Functional Roles of BRI2 and its Domains

The various forms and fragments of BRI2 are implicated in a range of cellular functions, with a notable connection to amyloidogenic pathways.

- **Regulation of Amyloid Precursor Protein (APP) Processing:** BRI2 physically interacts with APP, the precursor to the amyloid-beta (A β) peptide central to Alzheimer's disease.[7][8] This

interaction is thought to sterically hinder the access of secretases (α -, β -, and γ -secretase) to their cleavage sites on APP, thereby reducing the production of A β .^[7]

- **Inhibition of A β Aggregation:** Both the released BRI2-23 peptide and the soluble BRI2-BRICHOS domain have been shown to inhibit the aggregation of A β into fibrils.^{[1][9]} The BRICHOS domain, in particular, acts as a molecular chaperone that can bind to aggregation-prone regions of A β , preventing the formation of toxic oligomers and amyloid plaques.^{[1][10]}^[11]
- **Neurite Outgrowth and Synaptic Function:** Emerging evidence suggests a role for BRI2 in neuronal development and function.^{[1][3]} The intracellular domain (BRI2 ICD) may translocate to the nucleus and regulate gene expression related to neurite outgrowth.^[5] Furthermore, mutations in BRI2 that cause FBD and FDD have been shown to impair glutamatergic synaptic transmission.^[12]
- **Cell Signaling:** The ability of BRI2 to form homodimers at the cell surface suggests it may function as a receptor or part of a receptor complex, potentially initiating intracellular signaling cascades upon binding to extracellular ligands.^{[1][4]}

Interaction of BRI2 with APP and its effect on A β production

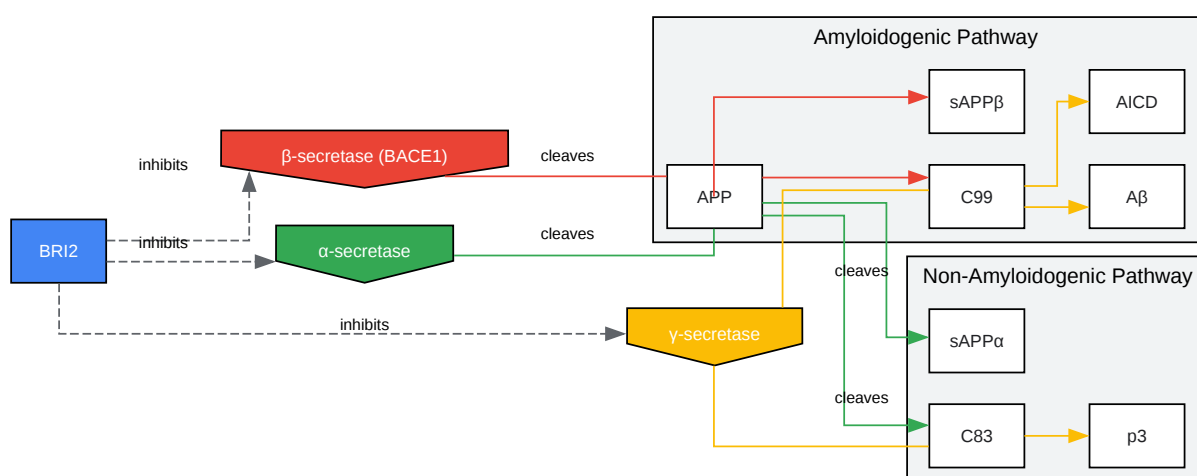

[Click to download full resolution via product page](#)

Caption: BRI2 inhibits both amyloidogenic and non-amyloidogenic processing of APP.

Experimental Protocols

This section provides detailed methodologies for key experiments commonly used in BRI2 research.

Co-Immunoprecipitation (Co-IP) to study BRI2-APP Interaction

Purpose: To determine if BRI2 and APP physically interact within a cellular context.

Materials:

- HEK293T cells co-transfected with plasmids expressing tagged BRI2 (e.g., HA-tag) and APP (e.g., FLAG-tag).
- Cell lysis buffer (e.g., RIPA buffer: 50 mM Tris-HCl pH 8.0, 150 mM NaCl, 1% NP-40, 0.5% sodium deoxycholate, 0.1% SDS) supplemented with protease and phosphatase inhibitors.
- Antibodies: anti-HA antibody for immunoprecipitation, anti-FLAG antibody for detection.
- Protein A/G magnetic beads.
- Wash buffer (e.g., lysis buffer with reduced detergent concentration).
- Elution buffer (e.g., 2x Laemmli sample buffer).
- Western blotting equipment and reagents.

Procedure:

- Cell Lysis:
 - Culture and transfect HEK293T cells. After 24-48 hours, wash cells with ice-cold PBS.
 - Lyse cells in ice-cold lysis buffer for 30 minutes on a rocker at 4°C.

- Centrifuge the lysate at 14,000 x g for 15 minutes at 4°C to pellet cell debris.
- Transfer the supernatant (protein lysate) to a new pre-chilled tube.
- Immunoprecipitation:
 - Pre-clear the lysate by incubating with protein A/G magnetic beads for 1 hour at 4°C.
 - Remove the beads and add the anti-HA antibody to the pre-cleared lysate. Incubate overnight at 4°C with gentle rotation.
 - Add fresh protein A/G magnetic beads and incubate for 2-4 hours at 4°C.
 - Pellet the beads using a magnetic stand and discard the supernatant.
- Washing and Elution:
 - Wash the beads three to five times with ice-cold wash buffer.
 - After the final wash, remove all supernatant and resuspend the beads in elution buffer.
 - Boil the samples at 95-100°C for 5-10 minutes to elute the protein complexes.
- Western Blot Analysis:
 - Separate the eluted proteins by SDS-PAGE.
 - Transfer the proteins to a PVDF or nitrocellulose membrane.
 - Probe the membrane with an anti-FLAG antibody to detect co-immunoprecipitated APP.
 - A band corresponding to the molecular weight of APP in the lane with the anti-HA immunoprecipitated sample indicates an interaction.

Experimental Workflow for Co-Immunoprecipitation

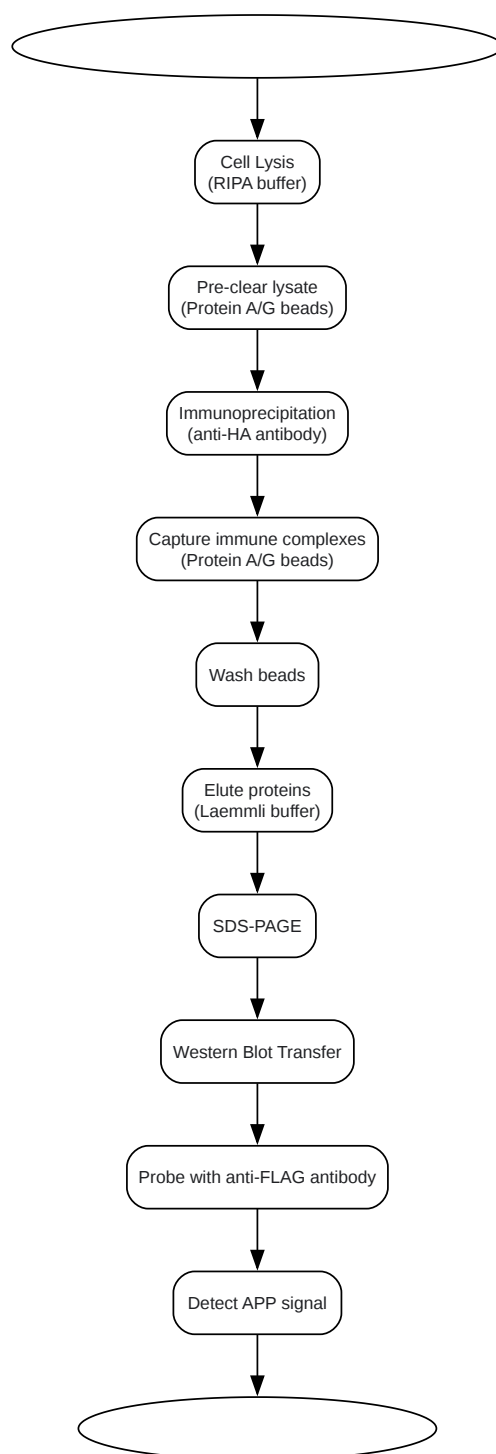

[Click to download full resolution via product page](#)

Caption: A streamlined workflow for co-immunoprecipitation.

Thioflavin T (ThT) Assay for A β Aggregation

Purpose: To quantitatively measure the effect of BRI2 fragments (e.g., BRI2-23 or BRI2-BRICHOS) on the kinetics of A β fibril formation.

Materials:

- Synthetic A β peptide (e.g., A β 42).
- BRI2-23 peptide or recombinant BRI2-BRICHOS domain.
- Thioflavin T (ThT) stock solution.
- Assay buffer (e.g., 50 mM phosphate buffer, 100 mM NaCl, pH 7.4).
- 96-well black, clear-bottom microplate.
- Plate reader with fluorescence detection capabilities (excitation ~440 nm, emission ~485 nm).

Procedure:

- Sample Preparation:
 - Prepare solutions of A β , BRI2 fragment, and ThT in the assay buffer.
 - In the wells of the microplate, set up reactions containing A β alone (control) and A β with different concentrations of the BRI2 fragment.
 - Add ThT to each well to a final concentration of ~10-20 μ M.
- Incubation and Measurement:
 - Incubate the plate at 37°C, with or without shaking, depending on the desired aggregation kinetics.
 - Measure the ThT fluorescence intensity at regular intervals (e.g., every 15-30 minutes) for several hours or days.
- Data Analysis:

- Plot the fluorescence intensity against time for each condition.
- The resulting sigmoidal curves represent the kinetics of amyloid fibril formation.
- Compare the lag time, elongation rate, and final fluorescence intensity between the control and the samples containing the BRI2 fragment to determine its inhibitory effect on A β aggregation.

Site-Directed Mutagenesis of the BRI2 Gene

Purpose: To introduce specific mutations into the BRI2 gene (e.g., to mimic FBD/FDD mutations or to study the function of specific residues) for subsequent expression and functional analysis.

Materials:

- Plasmid DNA containing the wild-type BRI2 cDNA.
- Mutagenic primers (forward and reverse) containing the desired mutation.
- High-fidelity DNA polymerase (e.g., Pfu or Q5).
- dNTPs.
- PCR buffer.
- DpnI restriction enzyme.
- Competent *E. coli* cells.
- LB agar plates with appropriate antibiotic.

Procedure:

- PCR Amplification:
 - Set up a PCR reaction containing the plasmid template, mutagenic primers, high-fidelity polymerase, dNTPs, and PCR buffer.

- Perform PCR to amplify the entire plasmid, incorporating the mutation. The number of cycles should be kept low (e.g., 12-18) to minimize the risk of secondary mutations.
- DpnI Digestion:
 - After PCR, add DpnI enzyme directly to the reaction mixture.
 - Incubate at 37°C for 1-2 hours. DpnI specifically digests the methylated parental plasmid DNA, leaving the newly synthesized, unmethylated, and mutated plasmid intact.
- Transformation:
 - Transform the DpnI-treated DNA into competent E. coli cells.
 - Plate the transformed cells on LB agar plates containing the appropriate antibiotic for plasmid selection.
- Screening and Sequencing:
 - Pick individual colonies and grow overnight cultures.
 - Isolate plasmid DNA from the cultures (miniprep).
 - Screen for the desired mutation by restriction digest (if the mutation creates or destroys a restriction site) or by DNA sequencing.
 - Confirm the presence of the desired mutation and the absence of any unintended mutations by sequencing the entire BRI2 insert.

Conclusion

The BRI2 protein is a multifaceted molecule with critical roles in regulating amyloidogenic pathways and maintaining neuronal health. Its intricate proteolytic processing and the diverse functions of its resulting fragments highlight the complexity of its biological activities. A thorough understanding of BRI2's structure and function is paramount for the development of novel therapeutic strategies for devastating neurodegenerative diseases like Alzheimer's, Familial British Dementia, and Familial Danish Dementia. The experimental protocols detailed in this

guide provide a foundation for researchers to further unravel the mysteries of this intriguing protein and its implications for human health.

Need Custom Synthesis?

BenchChem offers custom synthesis for rare earth carbides and specific isotopic labeling.

Email: info@benchchem.com or [Request Quote Online](#).

References

- [1. Thioflavin-T \(ThT\) Aggregation assay protocol 1000 \[protocols.io\]](#)
- [2. Cell Culture Transfection of HEK293 with cDNA and/or siRNA \[protocols.io\]](#)
- [3. bio-protocol.org \[bio-protocol.org\]](#)
- [4. bio-rad.com \[bio-rad.com\]](#)
- [5. creative-diagnostics.com \[creative-diagnostics.com\]](#)
- [6. Site Directed Mutagenesis \[kingsley.stanford.edu\]](#)
- [7. Culture and transfection of HEK293T cells \[protocols.io\]](#)
- [8. biotium.com \[biotium.com\]](#)
- [9. Immunofluorescence Protocol for use on cultured cell lines \(IF-IC\) \[protocols.io\]](#)
- [10. benchchem.com \[benchchem.com\]](#)
- [11. azurebiosystems.com \[azurebiosystems.com\]](#)
- [12. Thioflavin T spectroscopic assay \[assay-protocol.com\]](#)
- To cite this document: BenchChem. [An In-depth Technical Guide to BRI2 Protein: Structure, Function, and Experimental Analysis]. BenchChem, [2026]. [Online PDF]. Available at: [\[https://www.benchchem.com/product/b12381730/docs#an-in-depth-technical-guide-to-bri2-protein-structure-function-and-experimental-analysis\]](https://www.benchchem.com/product/b12381730/docs#an-in-depth-technical-guide-to-bri2-protein-structure-function-and-experimental-analysis)

Disclaimer & Data Validity:

The information provided in this document is for Research Use Only (RUO) and is strictly not intended for diagnostic or therapeutic procedures. While BenchChem strives to provide

accurate protocols, we make no warranties, express or implied, regarding the fitness of this product for every specific experimental setup.

Technical Support: The protocols provided are for reference purposes. Unsure if this reagent suits your experiment?

Need Industrial/Bulk Grade? [Request Custom Synthesis Quote](#)

BenchChem

Our mission is to be the trusted global source of essential and advanced chemicals, empowering scientists and researchers to drive progress in science and industry.

Contact

Address: 3281 E Guasti Rd

Ontario, CA 91761, United States

Phone: (601) 213-4426

Email: info@benchchem.com

[Contact our Ph.D. Support Team for a compatibility check](#)