

# Unveiling the Impact of PPM-3 on Downstream Signaling: A Comparative Analysis

**Author:** BenchChem Technical Support Team. **Date:** April 2026

## Compound of Interest

Compound Name: PPM-3  
Cat. No.: B12380543

[Get Quote](#)

For researchers, scientists, and drug development professionals, this guide provides an objective comparison of the hypothetical protein phosphatase **PPM-3**'s effects on key signaling pathways. As "**PPM-3**" is not a recognized protein, this analysis utilizes two well-characterized members of the Protein Phosphatase Magnesium-dependent (PPM) family, PPM1A and PPM1D (also known as Wip1), as representative models. This guide delves into their influence on the TGF- $\beta$ /SMAD and p53/DNA Damage Response pathways, respectively, and compares their modulation with established alternative therapeutic strategies.

This document presents supporting experimental data in structured tables, details key experimental protocols, and provides visualizations of signaling cascades and workflows to facilitate a comprehensive understanding of the functional roles of these phosphatases.

## Section 1: PPM1A and the TGF- $\beta$ /SMAD Signaling Pathway

PPM1A is a serine/threonine phosphatase that plays a crucial role in the negative regulation of the Transforming Growth Factor-beta (TGF- $\beta$ ) signaling pathway.<sup>[1][2][3]</sup> It directly dephosphorylates and inactivates the receptor-regulated SMADs (R-SMADs), specifically

SMAD2 and SMAD3, which are key transducers of the TGF- $\beta$  signal.[1][2][3] This dephosphorylation leads to the termination of the TGF- $\beta$  signal.

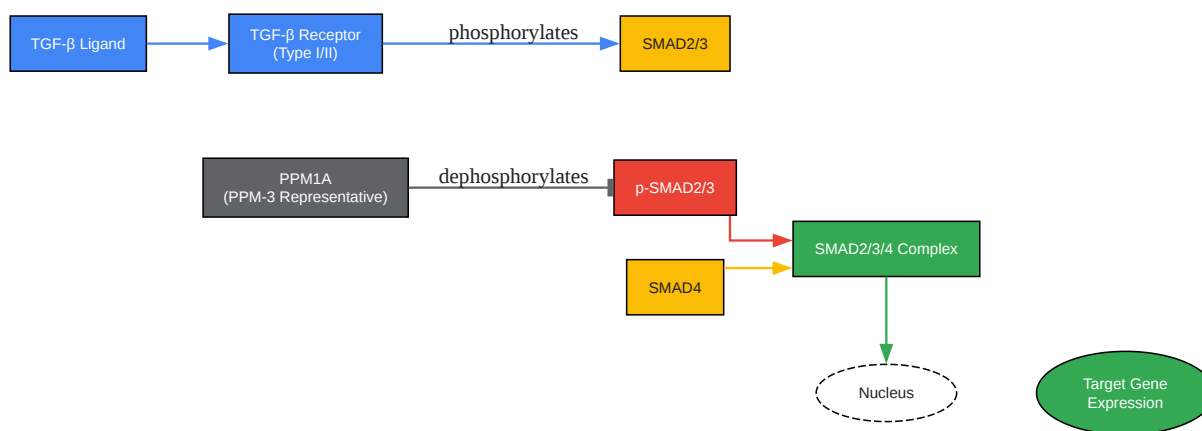

[Click to download full resolution via product page](#)

**Figure 1.** TGF- $\beta$ /SMAD signaling pathway with PPM1A regulation.

## Comparative Performance: PPM1A Modulation vs. Alternative

The effect of PPM1A on the TGF- $\beta$  pathway can be indirectly modulated using small molecule inhibitors. An alternative approach to inhibit this pathway is to target the TGF- $\beta$  type I receptor (ALK5) directly. Galunisertib (LY2157299) is a potent and selective inhibitor of ALK5.[4][5]

Parameter	PPM1A Inhibitor (SMIP-30)	ALK5 Inhibitor (Galunisertib)	Reference
Target	PPM1A phosphatase	TGF- $\beta$ Type I Receptor (ALK5) kinase	N/A
Mechanism of Action	Prevents dephosphorylation of p-SMAD2/3	Prevents phosphorylation of SMAD2/3	N/A
IC50	~1.3 $\mu$ M (in vitro)	56 nM (in vitro)	[4]
Effect on p-SMAD2 levels	Increases/maintains	Decreases	N/A

## Experimental Protocols

This assay quantifies the enzymatic activity of PPM1A.

- Reagents: Purified recombinant PPM1A, phosphorylated SMAD2 (p-SMAD2) substrate, phosphatase assay buffer (e.g., 50 mM Tris-HCl pH 7.5, 100 mM NaCl, 5 mM MgCl<sub>2</sub>, 1 mM DTT), Malachite Green Phosphate Detection Kit.
- Procedure:
  - Prepare serial dilutions of the PPM1A inhibitor (e.g., SMIP-30) in the assay buffer.
  - In a 96-well plate, add purified PPM1A and the inhibitor dilutions.
  - Initiate the reaction by adding the p-SMAD2 substrate.
  - Incubate at 30°C for a specified time (e.g., 30 minutes).
  - Stop the reaction and measure the amount of free phosphate released using the Malachite Green reagent according to the manufacturer's instructions.
  - Calculate the percentage of inhibition relative to a no-inhibitor control.

This method is used to detect the phosphorylation status of SMAD2 in response to TGF- $\beta$  stimulation and inhibitor treatment.

- Cell Culture and Treatment:
  - Culture cells (e.g., HaCaT keratinocytes) to 70-80% confluency.
  - Pre-treat cells with a PPM1A inhibitor or an ALK5 inhibitor for 1-2 hours.
  - Stimulate the cells with TGF- $\beta$ 1 (e.g., 5 ng/mL) for 30-60 minutes.
- Protein Extraction:
  - Wash cells with ice-cold PBS and lyse with RIPA buffer containing protease and phosphatase inhibitors.
  - Quantify protein concentration using a BCA assay.
- Electrophoresis and Transfer:
  - Separate protein lysates (20-30  $\mu$ g) on an SDS-PAGE gel and transfer to a PVDF membrane.
- Immunoblotting:
  - Block the membrane with 5% BSA in TBST for 1 hour.
  - Incubate with a primary antibody against p-SMAD2 (Ser465/467) overnight at 4°C.
  - Wash and incubate with an HRP-conjugated secondary antibody for 1 hour at room temperature.
  - Detect the signal using an ECL substrate and an imaging system.
  - Normalize p-SMAD2 levels to total SMAD2 or a housekeeping protein like GAPDH.

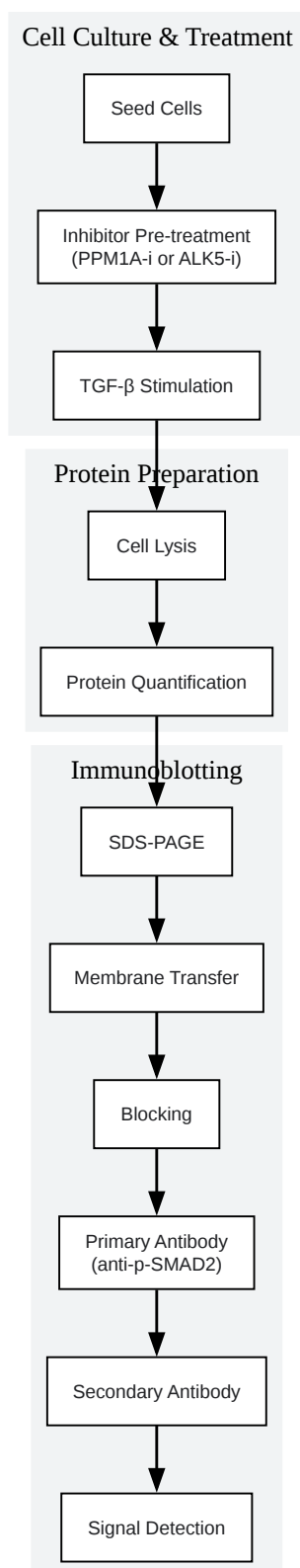

[Click to download full resolution via product page](#)

**Figure 2.** Experimental workflow for Western Blot analysis of p-SMAD2.



Parameter	PPM1D Inhibitor (GSK2830371)	MDM2 Inhibitor (Nutlin-3a)	Reference
Target	PPM1D phosphatase	MDM2 E3 ubiquitin ligase	N/A
Mechanism of Action	Prevents dephosphorylation of p-p53	Prevents p53 binding to MDM2, inhibiting its degradation	[11]
GI50 (MCF-7 cells)	~1 $\mu$ M (as a single agent)	~8 $\mu$ M	[12]
Effect on p-p53 (Ser15) levels	Increases	Increases	[12]
Effect on Cell Viability	Modest as single agent, potentiation with MDM2i	Induces cell cycle arrest and apoptosis	[12]

## Experimental Protocols

This assay measures the metabolic activity of cells as an indicator of cell viability after treatment with inhibitors.

- **Cell Seeding:** Seed cancer cells (e.g., MCF-7) in a 96-well plate and allow them to adhere overnight.
- **Compound Treatment:** Treat the cells with serial dilutions of a PPM1D inhibitor, an MDM2 inhibitor, or a combination of both for a specified duration (e.g., 72 hours).
- **MTT Addition:** Add MTT solution (3-(4,5-dimethylthiazol-2-yl)-2,5-diphenyltetrazolium bromide) to each well and incubate for 2-4 hours at 37°C. Viable cells will reduce the yellow MTT to purple formazan crystals.
- **Solubilization:** Remove the medium and add a solubilizing agent (e.g., DMSO) to dissolve the formazan crystals.
- **Absorbance Measurement:** Measure the absorbance at 570 nm using a microplate reader.

- **Data Analysis:** Calculate the percentage of cell viability relative to untreated control cells and determine the GI50 (the concentration that inhibits cell growth by 50%).

This technique is used to assess the interaction between p53 and its negative regulator MDM2.

- **Cell Treatment and Lysis:** Treat cells with a PPM1D or MDM2 inhibitor. Lyse the cells in a non-denaturing lysis buffer.
- **Immunoprecipitation:**
  - Pre-clear the cell lysates with protein A/G agarose beads.
  - Incubate the lysates with an antibody against p53 or MDM2 overnight at 4°C.
  - Add protein A/G agarose beads to pull down the antibody-protein complexes.
- **Washing:** Wash the beads several times to remove non-specific binding.
- **Elution and Western Blot:** Elute the protein complexes from the beads and analyze the presence of the co-immunoprecipitated protein (MDM2 or p53, respectively) by Western blot.

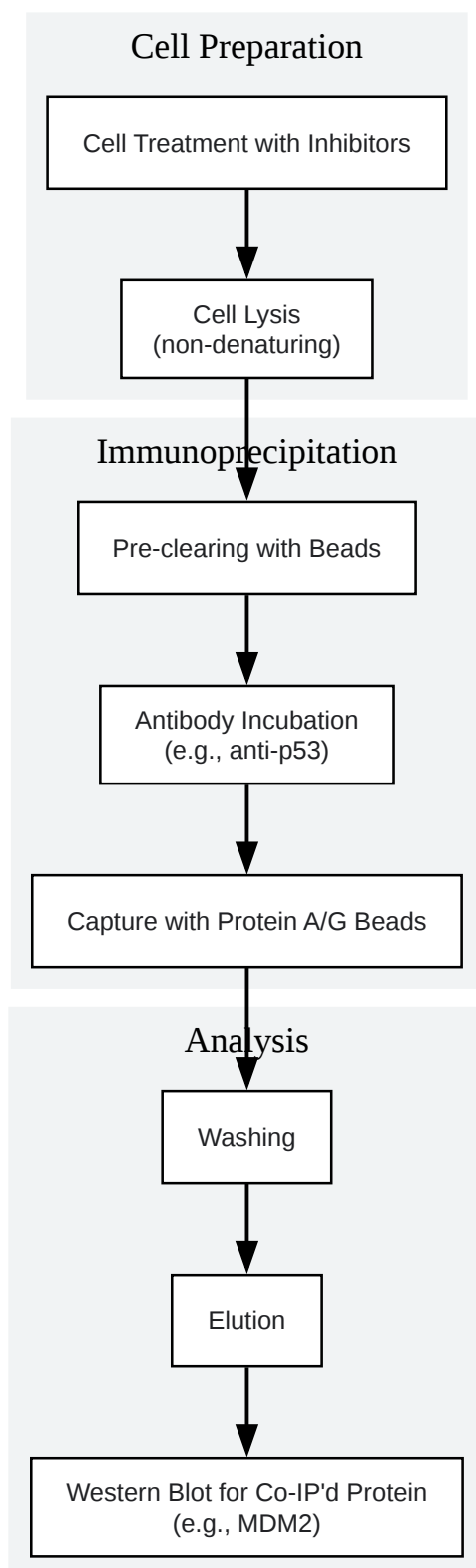

[Click to download full resolution via product page](#)

**Figure 4.** Experimental workflow for Co-Immunoprecipitation.

**Need Custom Synthesis?**

BenchChem offers custom synthesis for rare earth carbides and specific isotopic labeling.

Email: [info@benchchem.com](mailto:info@benchchem.com) or [Request Quote Online](#).

## References

- 1. PPM1A Functions as a Smad Phosphatase to Terminate TGF $\beta$  Signaling - PMC [[pmc.ncbi.nlm.nih.gov](https://pubmed.ncbi.nlm.nih.gov/)]
- 2. Regulation of TGF- $\beta$  Signaling by Protein Phosphatases - PMC [[pmc.ncbi.nlm.nih.gov](https://pubmed.ncbi.nlm.nih.gov/)]
- 3. Protein phosphatase PPM1A inhibition attenuates osteoarthritis via regulating TGF- $\beta$ /Smad2 signaling in chondrocytes - PMC [[pmc.ncbi.nlm.nih.gov](https://pubmed.ncbi.nlm.nih.gov/)]
- 4. Recent Advances in the Development of TGF- $\beta$  Signaling Inhibitors for Anticancer Therapy - PMC [[pmc.ncbi.nlm.nih.gov](https://pubmed.ncbi.nlm.nih.gov/)]
- 5. [jcpjournal.org](https://jcpjournal.org) [[jcpjournal.org](https://jcpjournal.org)]
- 6. [rupress.org](https://rupress.org) [[rupress.org](https://rupress.org)]
- 7. High Expression of PPM1D Induces Tumors Phenotypically Similar to TP53 Loss-of-Function Mutations in Mice - PMC [[pmc.ncbi.nlm.nih.gov](https://pubmed.ncbi.nlm.nih.gov/)]
- 8. [mdpi.com](https://mdpi.com) [[mdpi.com](https://mdpi.com)]
- 9. Therapeutic Strategies to Activate p53 [[mdpi.com](https://mdpi.com)]
- 10. PPM1D suppresses p53-dependent transactivation and cell death by inhibiting the Integrated Stress Response - PMC [[pmc.ncbi.nlm.nih.gov](https://pubmed.ncbi.nlm.nih.gov/)]
- 11. Reviving the guardian of the genome: small molecule activators of p53 - PMC [[pmc.ncbi.nlm.nih.gov](https://pubmed.ncbi.nlm.nih.gov/)]
- 12. [aacrjournals.org](https://aacrjournals.org) [[aacrjournals.org](https://aacrjournals.org)]
- To cite this document: BenchChem. [Unveiling the Impact of PPM-3 on Downstream Signaling: A Comparative Analysis]. BenchChem, [2026]. [Online PDF]. Available at: [<https://www.benchchem.com/product/b12380543/docs#unveiling-the-impact-of-ppm-3-on-downstream-signaling-a-comparative-analysis>]

---

**Disclaimer & Data Validity:**

The information provided in this document is for Research Use Only (RUO) and is strictly not intended for diagnostic or therapeutic procedures. While BenchChem strives to provide accurate protocols, we make no warranties, express or implied, regarding the fitness of this product for every specific experimental setup.

**Technical Support:** The protocols provided are for reference purposes. Unsure if this reagent suits your experiment?

**Need Industrial/Bulk Grade?** [Request Custom Synthesis Quote](#)

## BenchChem

Our mission is to be the trusted global source of essential and advanced chemicals, empowering scientists and researchers to drive progress in science and industry.

### Contact

Address: 3281 E Guasti Rd  
Ontario, CA 91761, United States  
Phone: (601) 213-4426  
Email: [info@benchchem.com](mailto:info@benchchem.com)

[Contact our Ph.D. Support Team for a compatibility check](#)