

Technical Support Center: Troubleshooting Inconsistent Results in BAY-9683 Experiments

Author: BenchChem Technical Support Team. **Date:** April 2026

Compound of Interest

Compound Name: BAY-9683
Cat. No.: B12380136

[Get Quote](#)

Welcome to the technical support center for **BAY-9683**. This resource is designed for researchers, scientists, and drug development professionals to provide guidance on troubleshooting inconsistent experimental results.

Frequently Asked Questions (FAQs)

Q1: What is **BAY-9683** and what is its primary mechanism of action?

BAY-9683 is a potent and selective covalent inverse agonist of Peroxisome Proliferator-Activated Receptor Gamma (PPAR γ).^{[1][2]} As a nuclear hormone receptor, PPAR γ , when activated, typically forms a heterodimer with the Retinoid X Receptor (RXR) and binds to specific DNA sequences called Peroxisome Proliferator Response Elements (PPREs) to regulate gene transcription. These genes are involved in adipogenesis, lipid metabolism, and inflammation.^{[3][4][5]}

Unlike agonists that activate PPAR γ , an inverse agonist like **BAY-9683** stabilizes a conformation of PPAR γ that promotes the recruitment of corepressors (e.g., NCOR1/2) and inhibits the recruitment of coactivators.^{[6][7][8]} This leads to the repression of target gene expression and can result in anti-proliferative effects in certain cancer cell lines, such as luminal bladder cancer.^[7]

Q2: What are the typical concentrations of **BAY-9683** used in cell-based assays?

The effective concentration of **BAY-9683** can vary significantly depending on the cell line, the specific endpoint being measured (e.g., target gene repression, cell viability), and the duration of the treatment. For in vitro experiments, it is crucial to perform a dose-response study with a wide range of concentrations (e.g., from low nanomolar to high micromolar) to determine the optimal concentration for your specific experimental setup.

Q3: My IC₅₀ value for **BAY-9683** varies between experiments. What could be the cause?

Inconsistent IC₅₀ values for covalent inhibitors like **BAY-9683** are a common issue. Due to their time-dependent mechanism of action, variations in pre-incubation time can significantly impact the measured potency.^{[1][2]} It is essential to standardize the pre-incubation time of the inhibitor with the cells or the target protein before measuring the effect. Other factors that can contribute to variability include:

- Batch-to-batch variability of the compound: It is recommended to verify the purity and identity of each new batch.^[1]
- Cell culture conditions: Variations in cell passage number, confluency, and serum concentration can affect cellular responses.
- Solubility and stability: Ensure that **BAY-9683** is fully dissolved and stable in your cell culture medium throughout the experiment.

Troubleshooting Guides

Issue 1: Weaker than Expected or No Biological Effect

Possible Causes and Troubleshooting Steps:

Possible Cause	Troubleshooting Steps
Compound Insolubility or Instability	Prepare fresh stock solutions of BAY-9683 in an appropriate solvent (e.g., DMSO) for each experiment. Ensure the final solvent concentration in the culture medium is low (typically <0.1%) and consistent across all treatments, including vehicle controls. Visually inspect the medium for any signs of precipitation.
Cell Line Insensitivity	Confirm that your cell line expresses sufficient levels of PPAR γ . Not all cell lines are sensitive to PPAR γ modulation. Consider using a positive control cell line known to be responsive to PPAR γ inverse agonists.
Suboptimal Experimental Conditions	Optimize the treatment duration. The effects of BAY-9683 on gene expression and cell viability may be time-dependent. Perform a time-course experiment (e.g., 24, 48, 72 hours) to identify the optimal endpoint.
Covalent Mechanism Not Established	To confirm the covalent binding of BAY-9683, perform washout experiments. After incubating cells with the inhibitor, wash the cells to remove any unbound compound and add fresh, inhibitor-free medium. If the inhibitory effect persists, it suggests a covalent interaction. ^{[2][9]}

Issue 2: Inconsistent Downstream Signaling Results

Possible Causes and Troubleshooting Steps:

Possible Cause	Troubleshooting Steps
Feedback Loop Activation	Inhibition of PPAR γ may lead to the activation of compensatory signaling pathways. For instance, there is known crosstalk between PPAR γ and pathways like NF- κ B and PI3K/Akt.[5] Analyze the expression or phosphorylation status of key proteins in related pathways to understand the cellular response more comprehensively.
Off-Target Effects	The reactive nature of covalent inhibitors can sometimes lead to off-target modifications.[2] If you observe unexpected phenotypes that cannot be explained by PPAR γ inhibition, consider performing proteomic studies to identify other potential targets. Compare the effects of BAY-9683 with other non-covalent PPAR γ inverse agonists if available.
Variability in Lysate Preparation	When analyzing protein expression or phosphorylation by Western blot, ensure consistent sample handling. Use lysis buffers containing protease and phosphatase inhibitors and keep samples on ice to preserve protein integrity and phosphorylation status.

Experimental Protocols

Cell Viability Assay (MTT Assay)

- **Cell Seeding:** Seed cells in a 96-well plate at a pre-determined optimal density in 100 μ L of complete culture medium and incubate for 24 hours to allow for cell attachment.
- **Compound Treatment:** Prepare serial dilutions of **BAY-9683** in culture medium. Remove the old medium from the wells and add 100 μ L of the medium containing the desired concentrations of **BAY-9683** or vehicle control.

- Incubation: Incubate the plate for the desired treatment duration (e.g., 48 or 72 hours) at 37°C in a 5% CO₂ incubator.
- MTT Addition: Add 20 µL of MTT solution (5 mg/mL in PBS) to each well and incubate for 4 hours at 37°C.
- Formazan Solubilization: Carefully remove the medium and add 150 µL of DMSO to each well to dissolve the formazan crystals.
- Absorbance Measurement: Measure the absorbance at 570 nm using a microplate reader.
- Data Analysis: Calculate the percentage of cell viability relative to the vehicle-treated control and plot the results to determine the IC₅₀ value.

Western Blot Analysis of PPAR γ Target Gene Expression

- Cell Treatment and Lysis: Seed cells in 6-well plates and treat with **BAY-9683** for the desired time. After treatment, wash the cells with ice-cold PBS and lyse them in RIPA buffer supplemented with protease and phosphatase inhibitors.
- Protein Quantification: Determine the protein concentration of the lysates using a BCA or Bradford assay.
- SDS-PAGE and Transfer: Load equal amounts of protein onto an SDS-polyacrylamide gel. After electrophoresis, transfer the proteins to a PVDF or nitrocellulose membrane.
- Immunoblotting: Block the membrane with 5% non-fat milk or BSA in TBST for 1 hour at room temperature. Incubate the membrane with a primary antibody against a known PPAR γ target gene product overnight at 4°C.
- Secondary Antibody and Detection: Wash the membrane with TBST and incubate with an appropriate HRP-conjugated secondary antibody for 1 hour at room temperature. Detect the signal using an enhanced chemiluminescence (ECL) substrate.
- Analysis: Quantify the band intensities and normalize to a loading control (e.g., β -actin or GAPDH).

Visualizations

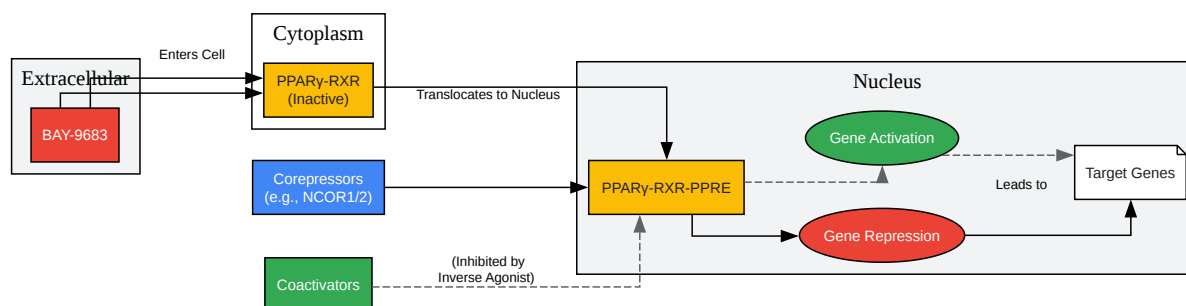

[Click to download full resolution via product page](#)

Caption: Mechanism of **BAY-9683** as a PPAR γ inverse agonist.

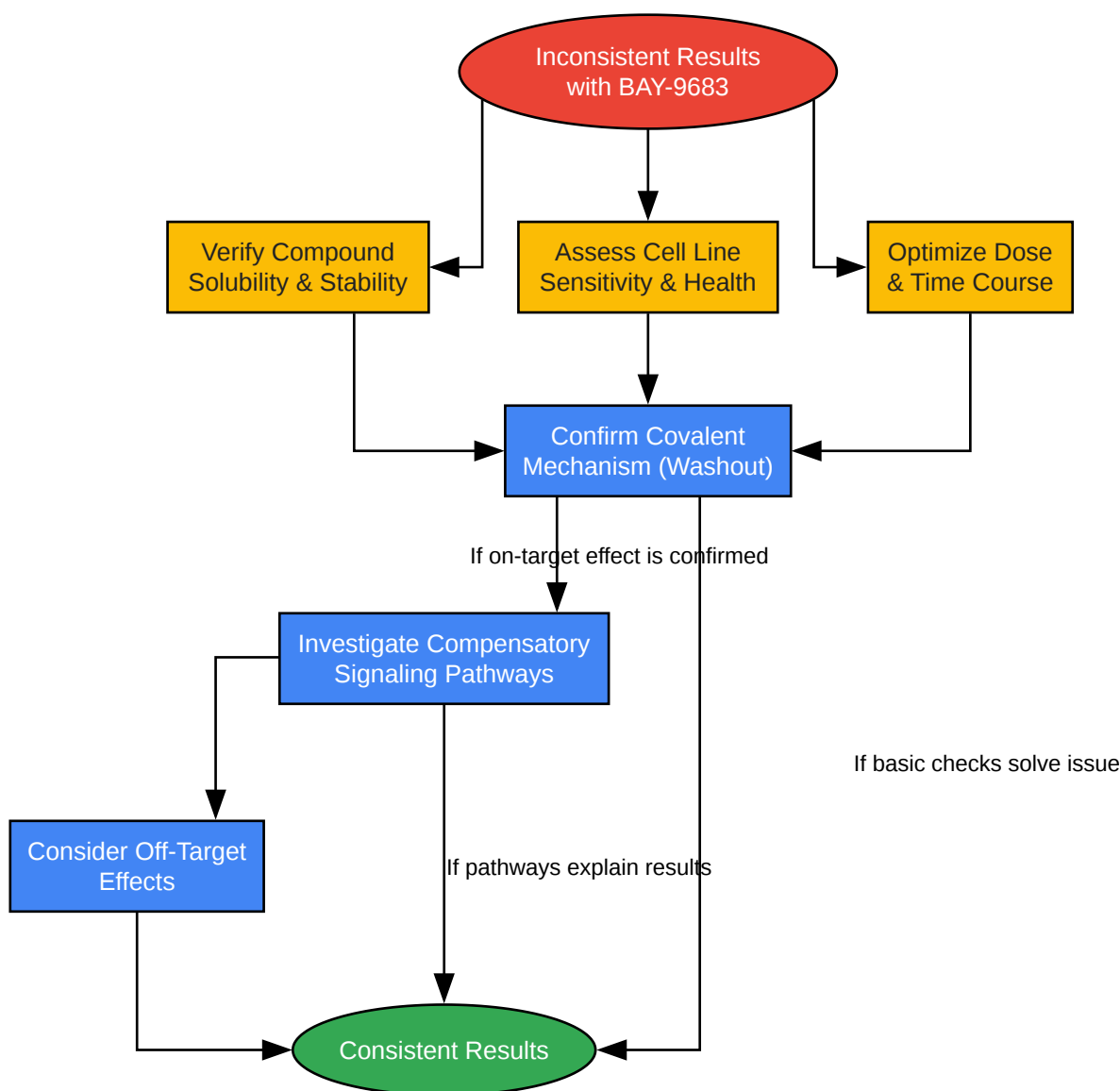

[Click to download full resolution via product page](#)

Caption: A logical workflow for troubleshooting inconsistent results.

Need Custom Synthesis?

BenchChem offers custom synthesis for rare earth carbides and specific isotopic labeling.

Email: info@benchchem.com or [Request Quote Online](#).

References

- [1. benchchem.com \[benchchem.com\]](#)
- [2. benchchem.com \[benchchem.com\]](#)
- [3. creative-diagnostics.com \[creative-diagnostics.com\]](#)
- [4. PPAR \$\gamma\$ signaling and metabolism: the good, the bad and the future - PMC \[pmc.ncbi.nlm.nih.gov\]](#)
- [5. Is PPAR gamma targeting a better strategy? \[synapse.patsnap.com\]](#)
- [6. Biochemical and structural basis for the pharmacological inhibition of nuclear hormone receptor PPAR \$\gamma\$ by inverse agonists - PMC \[pmc.ncbi.nlm.nih.gov\]](#)
- [7. Discovery and Structure-Based Design of Potent Covalent PPAR \$\gamma\$ Inverse-Agonists BAY-4931 and BAY-0069 - PMC \[pmc.ncbi.nlm.nih.gov\]](#)
- [8. pubs.acs.org \[pubs.acs.org\]](#)
- [9. Recent Advances in Selective and Irreversible Covalent Ligand Development and Validation - PMC \[pmc.ncbi.nlm.nih.gov\]](#)
- [To cite this document: BenchChem. \[Technical Support Center: Troubleshooting Inconsistent Results in BAY-9683 Experiments\]. BenchChem, \[2026\]. \[Online PDF\]. Available at: \[https://www.benchchem.com/product/b12380136/docs#technical-support-center-troubleshooting-inconsistent-results-in-bay-9683-experiments\]](#)

Disclaimer & Data Validity:

The information provided in this document is for Research Use Only (RUO) and is strictly not intended for diagnostic or therapeutic procedures. While BenchChem strives to provide accurate protocols, we make no warranties, express or implied, regarding the fitness of this product for every specific experimental setup.

Technical Support: The protocols provided are for reference purposes. Unsure if this reagent suits your experiment?

Need Industrial/Bulk Grade? [Request Custom Synthesis Quote](#)

BenchChem

Our mission is to be the trusted global source of essential and advanced chemicals, empowering scientists and researchers to drive progress in science and industry.

Contact

Address: 3281 E Guasti Rd

Ontario, CA 91761, United States

Phone: (601) 213-4426

Email: info@benchchem.com

[Contact our Ph.D. Support Team for a compatibility check](#)