

# Technical Support Center: Optimizing BRD2492 Concentration for Cell Viability Experiments

**Author:** BenchChem Technical Support Team. **Date:** April 2026

## Compound of Interest

Compound Name: BRD2492

Cat. No.: B12380826

[Get Quote](#)

This technical support center provides troubleshooting guidance and frequently asked questions (FAQs) for researchers, scientists, and drug development professionals working with **BRD2492**. Our goal is to help you optimize the concentration of this potent and selective HDAC1 and HDAC2 inhibitor to achieve reliable and reproducible cell viability results in your experiments.

## Frequently Asked Questions (FAQs)

Q1: What is the mechanism of action for **BRD2492**?

A1: **BRD2492** is a potent and selective inhibitor of histone deacetylases 1 (HDAC1) and 2 (HDAC2). HDACs are enzymes that remove acetyl groups from histone and non-histone proteins. By inhibiting HDAC1 and HDAC2, **BRD2492** leads to an increase in protein acetylation. This alteration in acetylation status can affect gene expression, leading to the induction of apoptosis (programmed cell death) and cell cycle arrest, thereby impacting cell viability.

Q2: What is a recommended starting concentration range for **BRD2492** in cell viability assays?

A2: The optimal concentration of **BRD2492** is highly dependent on the specific cell line being used. Based on available data, a broad starting range of 0.1  $\mu\text{M}$  to 50  $\mu\text{M}$  is recommended for initial dose-response experiments. It is crucial to perform a dose-response curve to determine the half-maximal inhibitory concentration (IC50) for your particular cell line.

Q3: How long should I incubate cells with **BRD2492**?

A3: Incubation time is a critical parameter that can significantly influence the observed effects on cell viability. Typical incubation periods for initial screening are 24, 48, and 72 hours. The choice of incubation time should be guided by the doubling time of your cell line and the specific biological question you are addressing.

Q4: I am observing inconsistent results between experiments. What are the common sources of variability?

A4: Inconsistent results in cell viability assays can stem from several factors:

- **Inconsistent Cell Seeding:** Ensure a homogeneous single-cell suspension before seeding and maintain consistent cell numbers across all wells.
- **Solvent Concentration:** If using a solvent like DMSO to dissolve **BRD2492**, ensure the final concentration is consistent across all wells, including controls, and is non-toxic to the cells.
- **Compound Stability:** Ensure proper storage and handling of **BRD2492** to maintain its activity. Prepare fresh dilutions for each experiment.
- **Assay-Specific Variability:** Factors such as incubation times, reagent concentrations, and plate reader settings can all contribute to variability. Refer to the specific troubleshooting guide for your chosen viability assay.

## Data Presentation: **BRD2492** IC50 Values

The following table summarizes the known half-maximal inhibitory concentration (IC50) values for **BRD2492** in various contexts. It is important to note that these values are cell-line specific and should be used as a reference for establishing your experimental concentration range.

| Target/Cell Line      | Assay Type        | IC50 Value    |
|-----------------------|-------------------|---------------|
| HDAC1                 | Enzymatic Assay   | 13.2 nM       |
| HDAC2                 | Enzymatic Assay   | 77.2 nM       |
| T-47D (Breast Cancer) | Growth Inhibition | 1.01 $\mu$ M  |
| MCF-7 (Breast Cancer) | Growth Inhibition | 11.13 $\mu$ M |

## Experimental Protocols

### Protocol 1: Determining Optimal Seeding Density

Optimizing cell seeding density is a critical first step to ensure logarithmic growth throughout the experiment.

- **Cell Preparation:** Culture cells to approximately 80% confluency. Harvest cells using standard trypsinization methods and create a single-cell suspension.
- **Cell Counting:** Accurately count the cells using a hemocytometer or an automated cell counter.
- **Serial Dilution:** Prepare a series of cell dilutions in complete culture medium.
- **Seeding:** Seed a 96-well plate with varying cell densities (e.g., from 1,000 to 20,000 cells per well).
- **Incubation:** Incubate the plate for 24, 48, and 72 hours.
- **Viability Assay:** At each time point, perform a cell viability assay (e.g., MTT) to determine the cell number.
- **Data Analysis:** Plot cell number versus time for each seeding density to identify the optimal density that allows for logarithmic growth throughout the intended duration of your drug treatment experiment.

### Protocol 2: MTT Assay for Cell Viability

The MTT (3-(4,5-dimethylthiazol-2-yl)-2,5-diphenyltetrazolium bromide) assay is a colorimetric assay for assessing cell metabolic activity.

- **Cell Seeding:** Seed cells into a 96-well plate at the predetermined optimal density in 100  $\mu\text{L}$  of complete culture medium and incubate for 24 hours to allow for attachment.
- **Compound Treatment:** Prepare serial dilutions of **BRD2492** in culture medium. A common starting point is a 10-point, 2-fold serial dilution starting from a high concentration (e.g., 100  $\mu\text{M}$ ). Remove the existing medium from the cells and add 100  $\mu\text{L}$  of the diluted compound. Include vehicle-only (e.g., DMSO) and no-treatment controls.
- **Incubation:** Incubate the plate for the desired duration (e.g., 24, 48, or 72 hours) at 37°C in a 5% CO<sub>2</sub> incubator.
- **MTT Addition:** Add 10  $\mu\text{L}$  of MTT solution (5 mg/mL in PBS) to each well.
- **Incubation with MTT:** Incubate the plate for 2-4 hours at 37°C, allowing the MTT to be metabolized into formazan crystals.
- **Solubilization:** Carefully remove the medium and add 100  $\mu\text{L}$  of a solubilization solution (e.g., DMSO or a specialized detergent-based solution) to each well to dissolve the formazan crystals.
- **Data Analysis:** Gently shake the plate for 5-10 minutes to ensure complete dissolution. Measure the absorbance at 570 nm using a microplate reader. Calculate the percentage of cell viability for each concentration relative to the vehicle control and plot the results to determine the IC<sub>50</sub> value.

## Troubleshooting Guides

### Issue 1: Low or No Effect of BRD2492 on Cell Viability

| Possible Cause            | Recommended Solution   |
|---------------------------|--|
| Concentration Too Low     | Perform a dose-response experiment with a wider and higher range of BRD2492 concentrations (e.g., up to 100 $\mu$ M).  |
| Incubation Time Too Short | The effects of HDAC inhibitors can take time to manifest. Increase the incubation period (e.g., test 48 and 72 hours).   |
| Cell Line Resistance      | The chosen cell line may be resistant to HDAC1/2 inhibition. Consider using a different cell line known to be sensitive or investigate the expression levels of HDAC1 and HDAC2 in your cells. |
| Compound Degradation      | Ensure BRD2492 has been stored correctly and prepare fresh dilutions from a concentrated stock for each experiment.  |

## Issue 2: High Variability Between Replicate Wells

| Possible Cause               | Recommended Solution  |
|------------------------------|---|
| Inconsistent Cell Seeding    | Ensure a homogenous cell suspension before plating and use calibrated multichannel pipettes for accurate dispensing.  |
| Edge Effects                 | Evaporation from wells on the edge of the plate can concentrate the compound and affect cell growth. To mitigate this, avoid using the outer wells of the 96-well plate for experimental samples and instead fill them with sterile PBS or media. |
| Inaccurate Compound Dilution | Prepare fresh serial dilutions of BRD2492 for each experiment. Ensure thorough mixing at each dilution step.  |
| Contamination                | Regularly check for mycoplasma contamination in your cell cultures. Use sterile techniques throughout the experimental process.   |

### Issue 3: Artifacts in MTT Assay Results

| Possible Cause                        | Recommended Solution   |
|---------------------------------------|--|
| Compound Interference                 | High concentrations of some compounds can directly reduce MTT, leading to a false-positive signal. Run a control with BRD2492 in cell-free media to check for direct reduction of MTT.       |
| Precipitation of Compound             | At high concentrations, BRD2492 may precipitate out of solution, which can interfere with absorbance readings. Visually inspect the wells under a microscope for any signs of precipitation. |
| Incomplete Solubilization of Formazan | Ensure the formazan crystals are completely dissolved before reading the plate. Increase incubation time with the solubilization solution or gently pipette up and down to aid dissolution.  |

## Visualizations

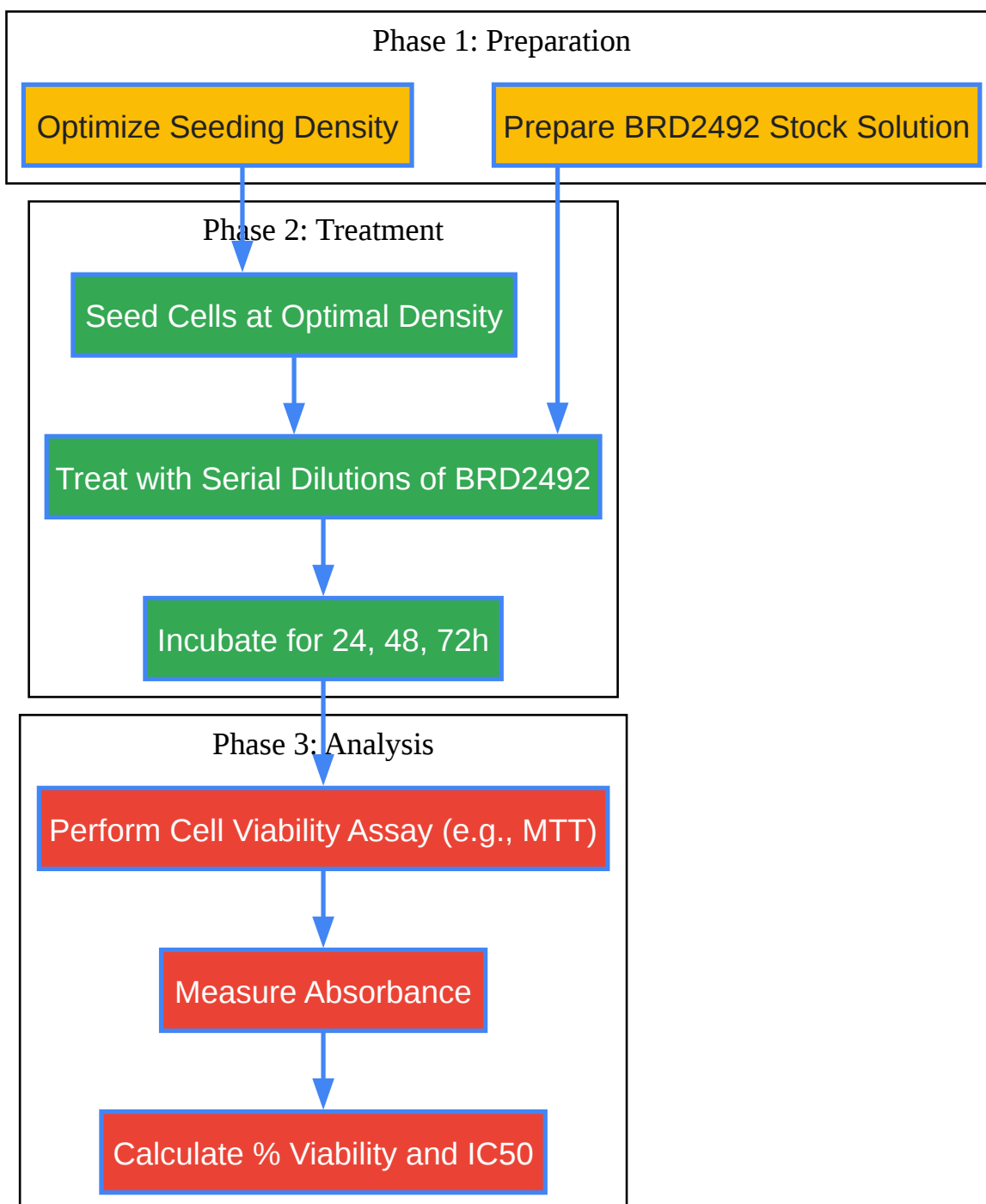

[Click to download full resolution via product page](#)

Caption: Workflow for optimizing **BRD2492** concentration.

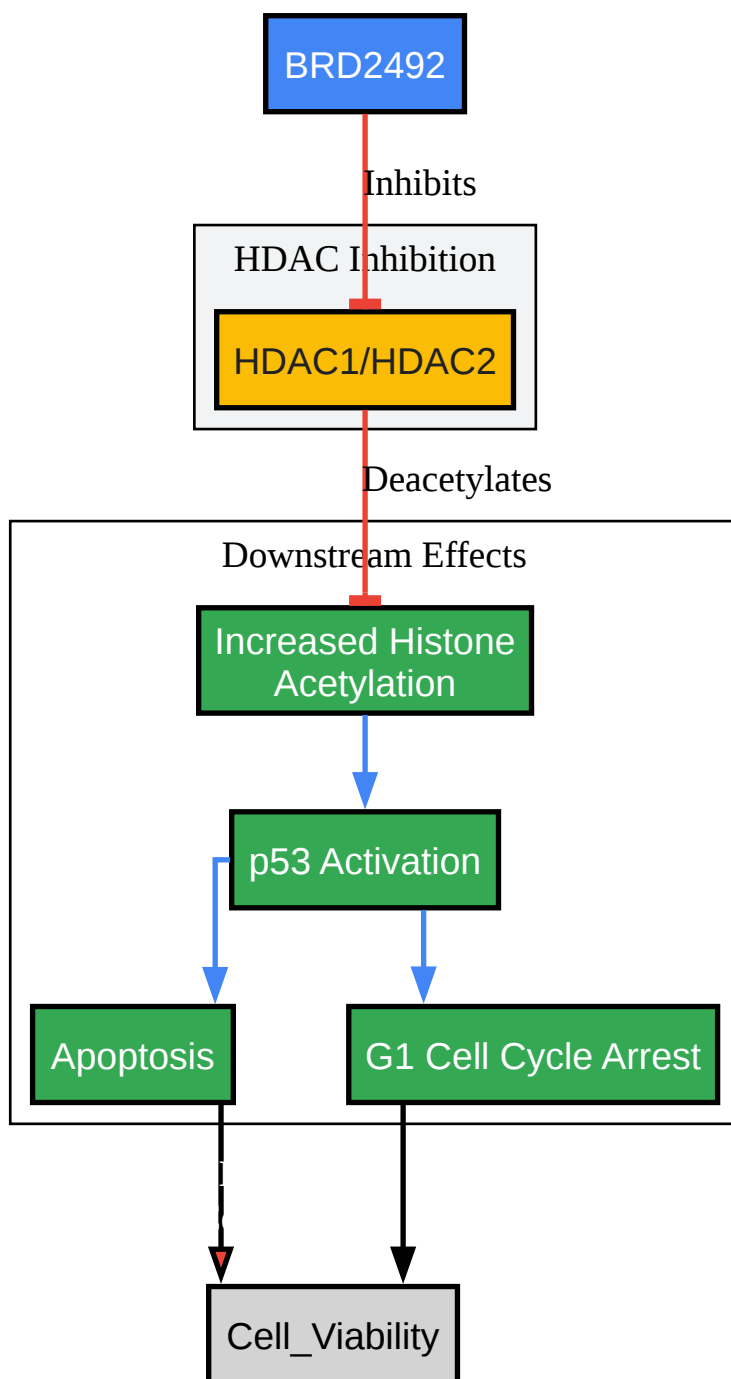

[Click to download full resolution via product page](#)

Caption: **BRD2492** signaling pathway overview.

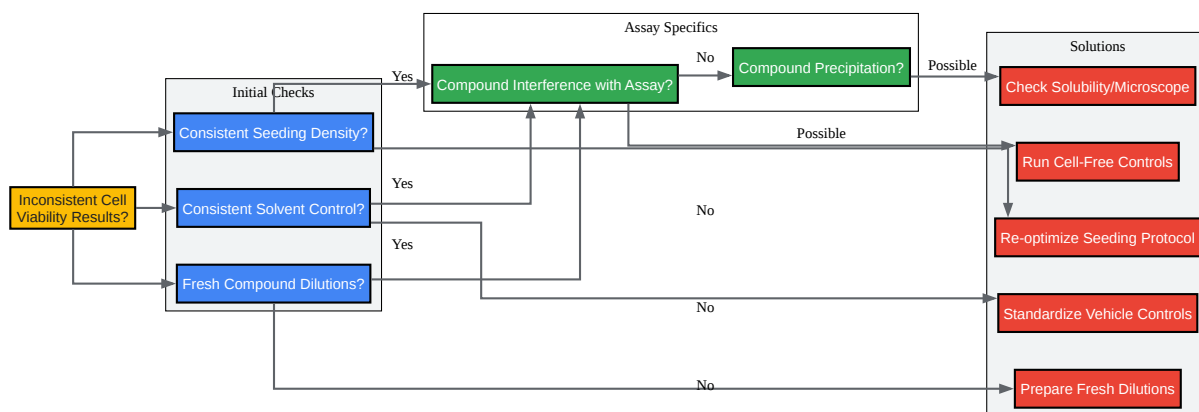

[Click to download full resolution via product page](#)

Caption: Troubleshooting decision tree for inconsistent results.

- To cite this document: BenchChem. [Technical Support Center: Optimizing BRD2492 Concentration for Cell Viability Experiments]. BenchChem, [2026]. [Online PDF]. Available at: [\[https://www.benchchem.com/product/b12380826/docs#technical-support-center-optimizing-brd2492-concentration-for-cell-viability-experiments\]](https://www.benchchem.com/product/b12380826/docs#technical-support-center-optimizing-brd2492-concentration-for-cell-viability-experiments)

### Disclaimer & Data Validity:

The information provided in this document is for Research Use Only (RUO) and is strictly not intended for diagnostic or therapeutic procedures. While BenchChem strives to provide

accurate protocols, we make no warranties, express or implied, regarding the fitness of this product for every specific experimental setup.

**Technical Support:** The protocols provided are for reference purposes. Unsure if this reagent suits your experiment?

**Need Industrial/Bulk Grade?** [Request Custom Synthesis Quote](#)

## BenchChem

Our mission is to be the trusted global source of essential and advanced chemicals, empowering scientists and researchers to drive progress in science and industry.

### Contact

Address: 3281 E Guasti Rd  
Ontario, CA 91761, United States  
Phone: (601) 213-4426  
Email: [info@benchchem.com](mailto:info@benchchem.com)

[Contact our Ph.D. Support Team for a compatibility check](#)