

# In Vitro Assays for Jasmoside Bioactivity: Application Notes and Protocols

**Author:** BenchChem Technical Support Team. **Date:** December 2025

## Compound of Interest

Compound Name: *Jasmoside*

Cat. No.: *B12380022*

[Get Quote](#)

For Researchers, Scientists, and Drug Development Professionals

These application notes provide a comprehensive overview of in vitro assays to evaluate the bioactivity of **Jasmoside**, an iridoid glycoside with potential therapeutic applications. The protocols and data presented herein are intended to guide researchers in the screening and characterization of **Jasmoside**'s anticancer, anti-inflammatory, and neuroprotective properties. While specific quantitative data for **Jasmoside** is limited in publicly available literature, the information provided is based on studies of structurally related jasmonates, such as jasmonic acid and methyl jasmonate, offering a strong foundation for experimental design.

## Anticancer Bioactivity: Cytotoxicity and Cell Viability Assays

The potential of **Jasmoside** as an anticancer agent can be initially assessed by evaluating its cytotoxic effects on various cancer cell lines. The MTT assay is a widely used colorimetric method to determine cell viability and proliferation.

## Quantitative Data for Related Jasmonates

While specific IC50 values for **Jasmoside** are not readily available, data for related jasmonates provide a preliminary indication of potential efficacy.

Compound	Cell Line	IC50 Value	Reference
Methyl Jasmonate	4T1 (Breast Cancer)	2.8 mM	[1]
Jasmonic Acid	DH82 (Canine Macrophage)	> Highest Tested Concentration	[2]
Methyl Jasmonate	DH82 (Canine Macrophage)	Lower than Jasmonic Acid	[2][3]
Jasmonic Acid	Molt-4 (Leukemia)	Effective at highest concentration	[4]
Methyl Jasmonate	Molt-4 (Leukemia)	87.5% cytotoxicity at 0.5 mM	[4]
Methyl Jasmonate	C33A and CaSki (Cervical Cancer)	More sensitive than HeLa and SiHa	[4]

## Experimental Protocol: MTT Assay

This protocol is adapted from standard MTT assay procedures and can be optimized for specific cell lines and experimental conditions.[5][6][7]

Materials:

- **Jasmoside** (dissolved in a suitable solvent, e.g., DMSO)
- Cancer cell lines of interest (e.g., MCF-7, A549, HeLa)
- Complete cell culture medium
- Phosphate-Buffered Saline (PBS)
- MTT (3-(4,5-dimethylthiazol-2-yl)-2,5-diphenyltetrazolium bromide) solution (5 mg/mL in PBS)
- Solubilization solution (e.g., DMSO, or 0.01 M HCl in 10% SDS)
- 96-well microplates

- Microplate reader

#### Procedure:

- **Cell Seeding:** Seed cells into a 96-well plate at a density of 5,000-10,000 cells/well in 100  $\mu$ L of complete culture medium. Incubate for 24 hours at 37°C in a humidified 5% CO<sub>2</sub> atmosphere.
- **Compound Treatment:** Prepare serial dilutions of **Jasmoside** in culture medium. Replace the old medium with 100  $\mu$ L of fresh medium containing various concentrations of **Jasmoside**. Include a vehicle control (medium with the same concentration of solvent used to dissolve **Jasmoside**) and a positive control (a known anticancer drug).
- **Incubation:** Incubate the plates for 24, 48, or 72 hours at 37°C.
- **MTT Addition:** After the incubation period, add 10  $\mu$ L of MTT solution to each well and incubate for 4 hours at 37°C.
- **Formazan Solubilization:** Carefully remove the medium and add 100  $\mu$ L of solubilization solution to each well to dissolve the formazan crystals.
- **Absorbance Measurement:** Measure the absorbance at 570 nm using a microplate reader.
- **Data Analysis:** Calculate the percentage of cell viability for each concentration of **Jasmoside** compared to the vehicle control. Determine the IC<sub>50</sub> value (the concentration of **Jasmoside** that inhibits 50% of cell growth) using a dose-response curve.

#### Experimental Workflow for MTT Assay

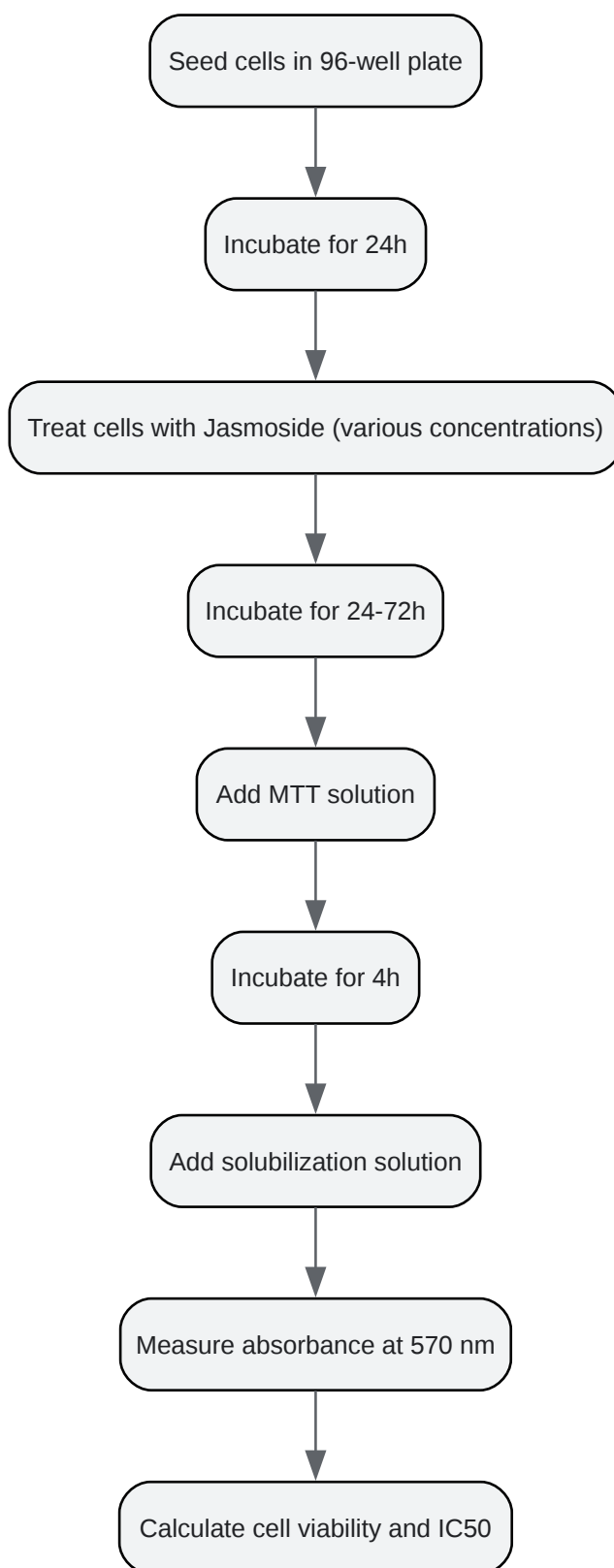

[Click to download full resolution via product page](#)

Workflow for the MTT cell viability assay.

## Anti-inflammatory Bioactivity

The anti-inflammatory potential of **Jasmoside** can be investigated through its ability to inhibit key inflammatory mediators and enzymes.

### Nitric Oxide (NO) Production Inhibition Assay

This assay determines the effect of **Jasmoside** on the production of nitric oxide, a pro-inflammatory mediator, in lipopolysaccharide (LPS)-stimulated macrophage cells (e.g., RAW 264.7).

Experimental Protocol: Griess Assay for Nitric Oxide

This protocol is based on the principle that nitrite (a stable product of NO) reacts with Griess reagent to form a colored azo compound.[\[8\]](#)[\[9\]](#)

Materials:

- **Jasmoside**
- RAW 264.7 macrophage cells
- Complete culture medium
- LPS (from E. coli)
- Griess Reagent (Part A: 1% sulfanilamide in 5% phosphoric acid; Part B: 0.1% N-(1-naphthyl)ethylenediamine dihydrochloride in water)
- Sodium nitrite (for standard curve)
- 96-well microplates
- Microplate reader

Procedure:

- Cell Seeding: Seed RAW 264.7 cells in a 96-well plate at a density of  $5 \times 10^4$  cells/well in 100  $\mu$ L of medium and incubate for 24 hours.

- **Compound Treatment:** Pre-treat the cells with various concentrations of **Jasmoside** for 1-2 hours.
- **LPS Stimulation:** Stimulate the cells with LPS (1 µg/mL) and incubate for 24 hours. Include a negative control (cells only), a vehicle control (cells + solvent + LPS), and a positive control (cells + known inhibitor + LPS).
- **Griess Reaction:** Transfer 50 µL of the cell culture supernatant to a new 96-well plate. Add 50 µL of Griess Reagent A, followed by 50 µL of Griess Reagent B.
- **Absorbance Measurement:** After a 10-minute incubation at room temperature, protected from light, measure the absorbance at 540 nm.
- **Data Analysis:** Generate a standard curve using known concentrations of sodium nitrite. Calculate the concentration of nitrite in the samples and determine the percentage of NO inhibition by **Jasmoside**. Calculate the IC50 value.

#### Workflow for Nitric Oxide Inhibition Assay

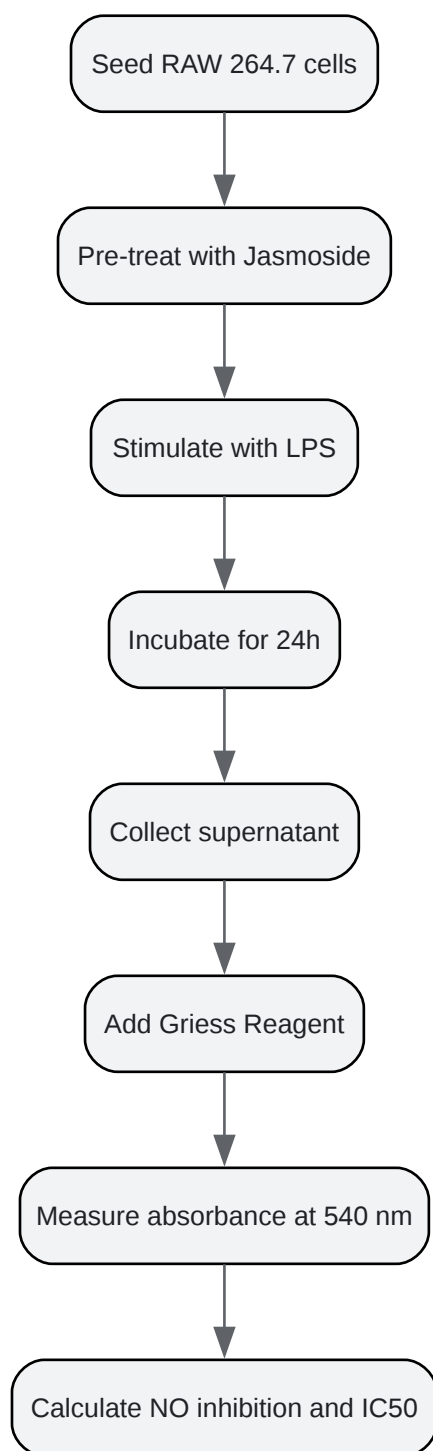

[Click to download full resolution via product page](#)

Workflow for the in vitro nitric oxide inhibition assay.

## Cyclooxygenase-2 (COX-2) and 5-Lipoxygenase (5-LOX) Inhibition Assays

These enzyme inhibition assays directly measure the ability of **Jasmoside** to inhibit the activity of COX-2 and 5-LOX, key enzymes in the inflammatory pathway responsible for the production of prostaglandins and leukotrienes, respectively.

### Experimental Protocol: COX-2 and 5-LOX Inhibition Assays

These protocols are based on commercially available assay kits.

#### COX-2 Inhibition Assay Protocol:

- Principle: Measures the peroxidase activity of COX-2, where the oxidation of a substrate by the enzyme in the presence of arachidonic acid leads to a fluorescent or colorimetric signal.
- General Procedure:
  - Prepare a reaction mixture containing assay buffer, heme, and a fluorometric or colorimetric probe.
  - Add the COX-2 enzyme to the mixture.
  - Add **Jasmoside** at various concentrations (and a known COX-2 inhibitor as a positive control).
  - Initiate the reaction by adding arachidonic acid.
  - Measure the fluorescence or absorbance over time using a microplate reader.
  - Calculate the percentage of inhibition and the IC50 value.

#### 5-LOX Inhibition Assay Protocol:

- Principle: Measures the ability of 5-LOX to catalyze the oxidation of a substrate (e.g., linoleic acid or arachidonic acid), which can be monitored by the increase in absorbance at a specific wavelength.[\[10\]](#)



- General Procedure:
  - Prepare a reaction buffer.
  - Add the 5-LOX enzyme.
  - Add **Jasmoside** at various concentrations (and a known 5-LOX inhibitor as a positive control).
  - Initiate the reaction by adding the substrate.
  - Measure the change in absorbance at the appropriate wavelength (e.g., 234 nm for linoleic acid) over time.
  - Calculate the percentage of inhibition and the IC<sub>50</sub> value.

## Signaling Pathways in Inflammation

**Jasmoside** may exert its anti-inflammatory effects by modulating key signaling pathways such as the NF- $\kappa$ B and MAPK pathways, which are central regulators of inflammatory gene expression.

### NF- $\kappa$ B Signaling Pathway

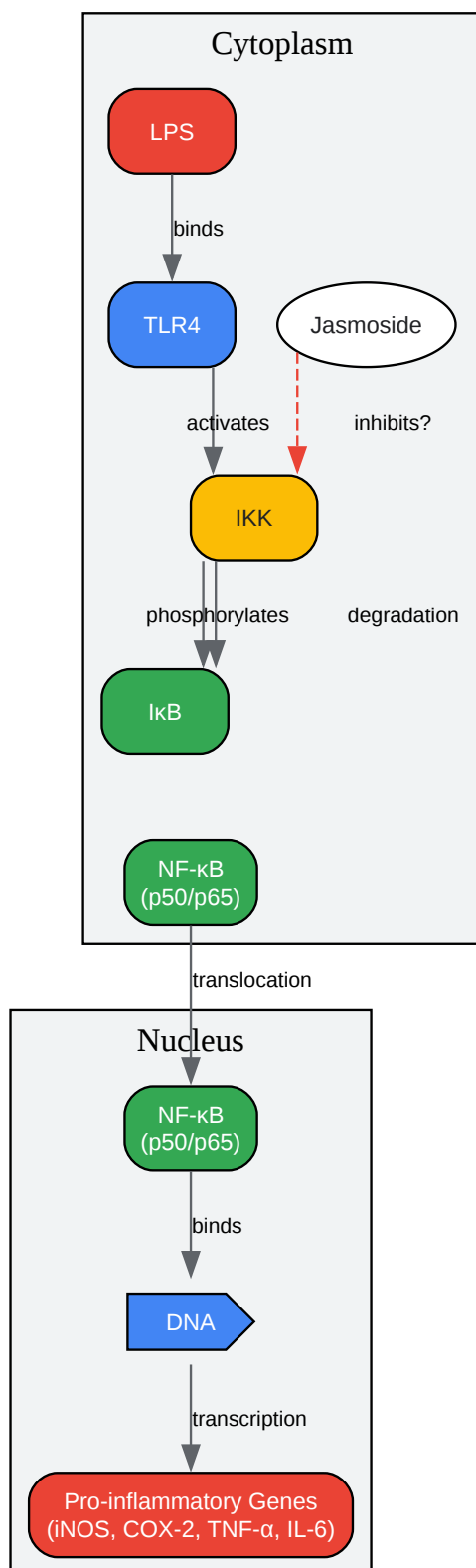

[Click to download full resolution via product page](#)

Hypothesized inhibition of the NF-κB signaling pathway by **Jasmomide**.

MAPK Signaling Pathway

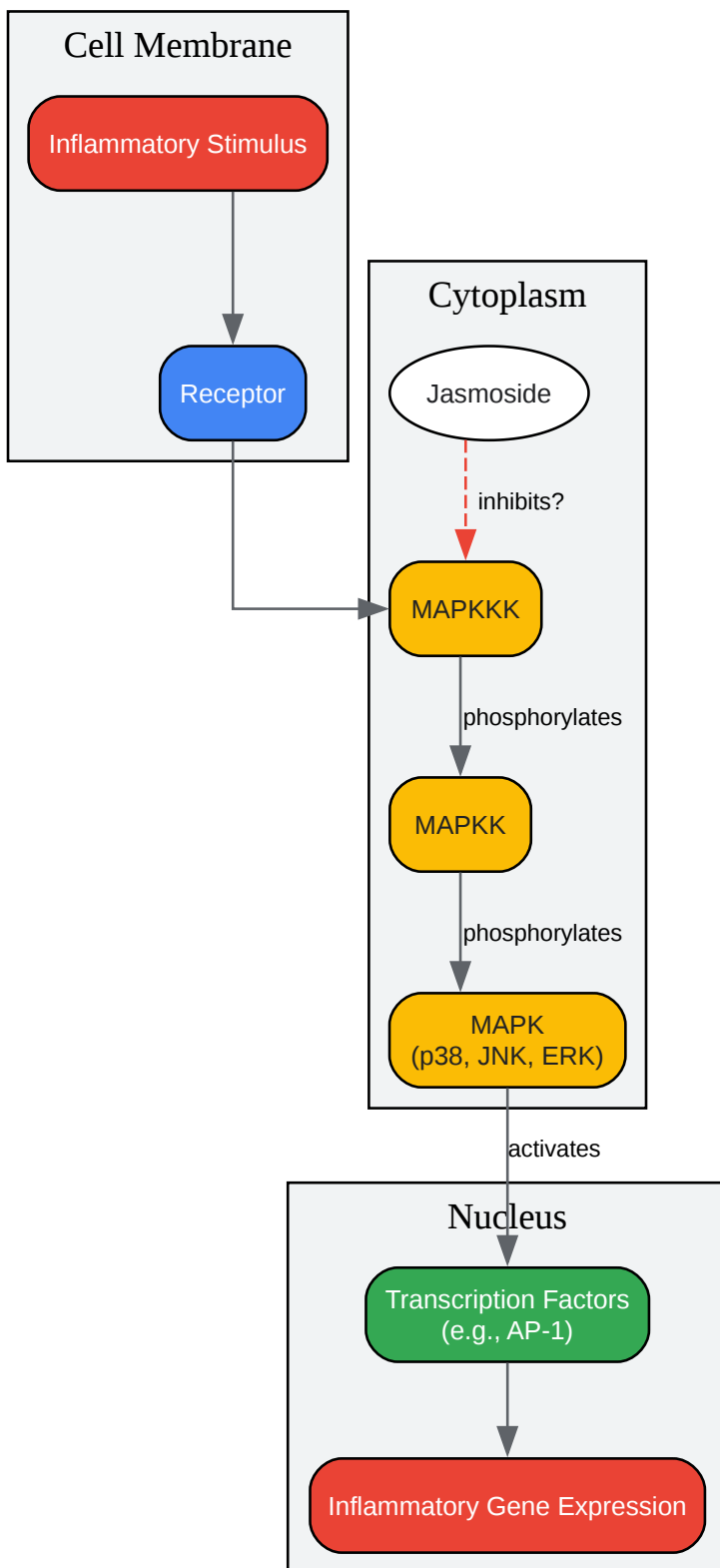

[Click to download full resolution via product page](#)

Potential modulation of the MAPK signaling pathway by **Jasmoside**.

## Neuroprotective Bioactivity

The neuroprotective effects of **Jasmoside** can be assessed in vitro by its ability to protect neuronal cells from various neurotoxic insults.

## Experimental Protocol: Neuroprotection Assay

This protocol describes a general method for evaluating neuroprotection using a neuronal cell line (e.g., SH-SY5Y or PC12) and a neurotoxin.

Materials:

- **Jasmoside**
- Neuronal cell line (e.g., SH-SY5Y)
- Cell culture medium
- Neurotoxin (e.g., 6-hydroxydopamine (6-OHDA), hydrogen peroxide (H<sub>2</sub>O<sub>2</sub>), or amyloid-beta peptide)
- MTT or other cell viability assay reagents
- 96-well microplates
- Microplate reader

Procedure:

- **Cell Seeding and Differentiation** (if applicable): Seed neuronal cells in a 96-well plate and, if necessary, differentiate them into a more mature neuronal phenotype according to established protocols.
- **Pre-treatment with Jasmoside**: Treat the cells with various concentrations of **Jasmoside** for a specified period (e.g., 1-24 hours).

- **Induction of Neurotoxicity:** Add the chosen neurotoxin to the wells (except for the control wells) and incubate for an appropriate duration to induce cell death.
- **Assessment of Cell Viability:** Perform a cell viability assay (e.g., MTT assay as described in Section 1) to quantify the extent of neuroprotection conferred by **Jasmoside**.
- **Data Analysis:** Calculate the percentage of neuroprotection for each concentration of **Jasmoside** compared to the neurotoxin-treated control. Determine the EC50 value (the concentration of **Jasmoside** that provides 50% of the maximum neuroprotective effect).

### Neuroprotective Signaling Pathways

**Jasmoside**, as an iridoid glycoside, may exert neuroprotective effects through the modulation of pathways like the PI3K/Akt signaling cascade, which is crucial for neuronal survival and apoptosis inhibition.

### PI3K/Akt Signaling Pathway

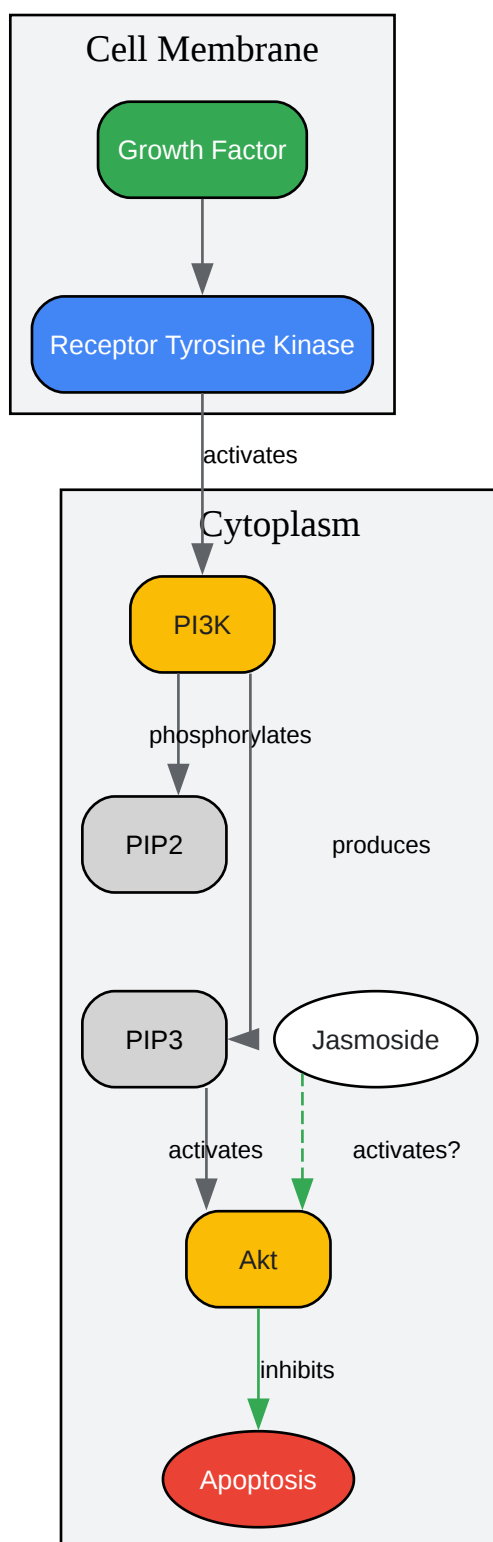

[Click to download full resolution via product page](#)

Hypothesized activation of the PI3K/Akt survival pathway by **Jasmoside**.

Disclaimer: The protocols provided are for guidance only and should be adapted and optimized for specific experimental conditions. The quantitative data presented are for compounds structurally related to **Jasmoside** and may not be directly representative of **Jasmoside**'s bioactivity. Further research is required to establish the specific in vitro bioactivity profile of **Jasmoside**.

### Need Custom Synthesis?

BenchChem offers custom synthesis for rare earth carbides and specific isotopic labeling.

Email: [info@benchchem.com](mailto:info@benchchem.com) or [Request Quote Online](#).

## References

- 1. [cdn.caymanchem.com](https://cdn.caymanchem.com) [[cdn.caymanchem.com](https://cdn.caymanchem.com)]
- 2. [abcam.com](https://abcam.com) [[abcam.com](https://abcam.com)]
- 3. [assaygenie.com](https://assaygenie.com) [[assaygenie.com](https://assaygenie.com)]
- 4. 2.8. Cyclooxygenase-2 (COX-2) Inhibition Assay [[bio-protocol.org](https://www.biorxiv.org/content/10.1101/004464v2)]
- 5. [bpsbioscience.com](https://bpsbioscience.com) [[bpsbioscience.com](https://bpsbioscience.com)]
- 6. Jasmonate Compounds and Their Derivatives in the Regulation of the Neoplastic Processes - PMC [[pmc.ncbi.nlm.nih.gov](https://pubmed.ncbi.nlm.nih.gov/11111111/)]
- 7. MTT assay protocol | Abcam [[abcam.com](https://abcam.com)]
- 8. [researchgate.net](https://researchgate.net) [[researchgate.net](https://researchgate.net)]
- 9. Chemical Constituents from the Roots of Jasminum sambac (L.) Ait. and their Cytotoxicity to the Cancer Cell Lines - PubMed [[pubmed.ncbi.nlm.nih.gov](https://pubmed.ncbi.nlm.nih.gov/11111111/)]
- 10. [biorxiv.org](https://www.biorxiv.org) [[biorxiv.org](https://www.biorxiv.org)]
- To cite this document: BenchChem. [In Vitro Assays for Jasmoside Bioactivity: Application Notes and Protocols]. BenchChem, [2025]. [Online PDF]. Available at: [<https://www.benchchem.com/product/b12380022#in-vitro-assays-for-jasmoside-bioactivity>]

### Disclaimer & Data Validity:

The information provided in this document is for Research Use Only (RUO) and is strictly not intended for diagnostic or therapeutic procedures. While BenchChem strives to provide

accurate protocols, we make no warranties, express or implied, regarding the fitness of this product for every specific experimental setup.

**Technical Support:** The protocols provided are for reference purposes. Unsure if this reagent suits your experiment? [[Contact our Ph.D. Support Team for a compatibility check](#)]

**Need Industrial/Bulk Grade?** [Request Custom Synthesis Quote](#)

## BenchChem

Our mission is to be the trusted global source of essential and advanced chemicals, empowering scientists and researchers to drive progress in science and industry.

### Contact

Address: 3281 E Guasti Rd

Ontario, CA 91761, United States

Phone: (601) 213-4426

Email: [info@benchchem.com](mailto:info@benchchem.com)