

Technical Support Center: Managing Variability in CITCO Response Between Hepatocyte Donors

Author: BenchChem Technical Support Team. **Date:** April 2026

Compound of Interest

Compound Name: Z-CITCO

Cat. No.: B1238009

[Get Quote](#)

This technical support center provides researchers, scientists, and drug development professionals with comprehensive guidance on managing the inherent variability observed in response to the nuclear receptor activator, 6-(4-chlorophenyl)imidazo[2,1-b][1][2]thiazole-5-carbaldehyde-O-(3,4-dichlorobenzyl)oxime (CITCO), across different lots of primary human hepatocytes. This resource offers troubleshooting guides, frequently asked questions (FAQs), detailed experimental protocols, and visual aids to facilitate robust and reproducible in vitro studies.

Frequently Asked Questions (FAQs)

Q1: What is CITCO and what is its primary mechanism of action in hepatocytes?

A1: CITCO is a well-established potent activator of the human Constitutive Androstane Receptor (CAR), a key nuclear receptor that regulates the expression of genes involved in drug metabolism and detoxification.[3] Upon activation, CAR translocates to the nucleus, forms a heterodimer with the Retinoid X Receptor (RXR), and binds to specific response elements on DNA to initiate the transcription of target genes, including cytochrome P450 (CYP) enzymes like CYP2B6 and CYP3A4.[4][5][6] Importantly, recent studies have demonstrated that CITCO can also directly bind to and activate the human Pregnane X Receptor (PXR), another critical

xenobiotic-sensing nuclear receptor.[7][8] This makes CITCO a dual agonist for both hCAR and hPXR, which is a crucial consideration when interpreting experimental data.[7][8]

Q2: Why do I observe significant differences in CYP enzyme induction with CITCO between different hepatocyte donor lots?

A2: Inter-individual variability in response to xenobiotics is a well-documented phenomenon in primary human hepatocytes and stems from a combination of factors:

- **Genetic Polymorphisms:** Genetic variations in the genes encoding for CAR (NR1I3) and PXR (NR1I2) can alter receptor expression levels and ligand binding affinity, leading to differential downstream gene induction.[9][10]
- **Donor Demographics:** Factors such as age, sex, ethnicity, and body mass index (BMI) of the hepatocyte donor can influence the baseline expression and activity of drug-metabolizing enzymes.[1][11]
- **Environmental Factors:** Prior exposure of the donor to drugs, dietary components, or environmental pollutants can alter the basal state of nuclear receptor activation and target gene expression.
- **Pathological Conditions:** Underlying liver conditions in the donor, such as steatosis (fatty liver), can impact hepatocyte function and their response to inducers.[12]
- **Experimental Variability:** Inconsistencies in cell handling, seeding density, and treatment duration can contribute significantly to variability in results.[13][14]

Q3: How can I minimize experimental variability in my CITCO induction studies?

A3: Adhering to standardized and optimized protocols is critical. Key considerations include:

- **Consistent Cell Handling:** Follow a strict protocol for thawing, plating, and culturing cryopreserved hepatocytes.[2][15][16][17]
- **Optimized Seeding Density:** Ensure a consistent and optimal cell seeding density to avoid under- or over-confluence, which can affect cell health and inducibility.[13][14]

- **Defined Treatment Duration:** Use a consistent treatment duration for CITCO exposure, as the time-course of induction can vary for mRNA and enzyme activity levels.[18]
- **Appropriate Controls:** Always include a vehicle control (e.g., DMSO) and a well-characterized positive control for each CYP isoform being investigated (e.g., rifampicin for CYP3A4, phenobarbital for CYP2B6).[19]
- **Use of Pooled Donors:** For some applications, using pooled hepatocytes from multiple donors can help average out individual differences and provide a more representative response of the general population.[1][20]

Q4: What are the expected fold-induction ranges for CYP enzymes with CITCO?

A4: The magnitude of CYP induction by CITCO can vary significantly between hepatocyte donors. The following table provides a general overview of expected induction ranges for key CYP enzymes. It is essential to establish baseline and induced levels for each new donor lot.

CYP Isoform	Prototypical Inducer	Typical CITCO Concentration	Expected Fold Induction (mRNA)
CYP3A4	Rifampicin	0.1 - 1 μ M	Highly variable, can range from low to high-fold induction.
CYP2B6	Phenobarbital	0.1 μ M	Significant induction, often used as a primary marker for CAR activation.
CYP1A2	Omeprazole	-	Generally not a direct target of CITCO-mediated induction.

Note: These are approximate ranges and the actual fold-induction will be donor-dependent. It is crucial to determine the EC50 and Emax for each donor lot.[18][21]

Troubleshooting Guide

Issue	Possible Cause(s)	Recommended Solution(s)
Low or no CYP induction with CITCO in a previously responsive donor lot.	<ul style="list-style-type: none"> - CITCO Degradation: Improper storage of CITCO solution. - Cell Health Issues: Poor viability or attachment of hepatocytes. - Incorrect Concentration: Error in dilution of CITCO stock. 	<ul style="list-style-type: none"> - Prepare fresh CITCO solutions and store them protected from light. - Assess cell viability post-thaw and ensure proper monolayer formation. - Verify the final concentration of CITCO in the culture medium.
High background (vehicle control) CYP activity.	<ul style="list-style-type: none"> - Donor History: Donor may have been on medication that induced CYP enzymes. - Media Components: Some media supplements can have modest inducing effects. 	<ul style="list-style-type: none"> - Review donor history if available. - Use a well-defined, serum-free culture medium. [16]
Inconsistent results between replicate wells.	<ul style="list-style-type: none"> - Uneven Cell Seeding: Improper mixing of cell suspension before plating. - Edge Effects: Evaporation from wells on the edge of the plate. 	<ul style="list-style-type: none"> - Gently swirl the plate in a north-south and east-west motion after seeding to ensure even distribution. [2] - Use the inner wells of the plate for experiments or fill the outer wells with sterile PBS to minimize evaporation.
Observed cytotoxicity at expected non-toxic CITCO concentrations.	<ul style="list-style-type: none"> - Donor Sensitivity: Some donors may be more sensitive to chemical insults. - Solvent Toxicity: High concentration of the vehicle (e.g., DMSO). 	<ul style="list-style-type: none"> - Perform a dose-response cytotoxicity assay for each new donor lot to determine the non-toxic concentration range. - Ensure the final vehicle concentration is low (typically $\leq 0.1\%$) and consistent across all treatments.

Experimental Protocols

Protocol 1: CYP450 Induction Assay in Primary Human Hepatocytes

This protocol details the steps for assessing the induction of CYP1A2, CYP2B6, and CYP3A4 mRNA levels following treatment with CITCO.

Materials:

- Cryopreserved primary human hepatocytes
- Hepatocyte plating and culture medium
- Collagen-coated culture plates (e.g., 24- or 48-well)
- CITCO, Rifampicin, Phenobarbital, Omeprazole
- DMSO (vehicle)
- RNA lysis buffer
- qRT-PCR reagents

Procedure:

- Thawing and Plating of Hepatocytes:
 - Pre-warm plating medium to 37°C.
 - Rapidly thaw the cryovial of hepatocytes in a 37°C water bath for approximately 90-120 seconds until a small ice crystal remains.[\[15\]](#)[\[16\]](#)
 - Wipe the vial with 70% ethanol and transfer the contents to a conical tube containing pre-warmed plating medium.
 - Centrifuge the cells at a low speed (e.g., 100 x g) for 5-10 minutes.[\[22\]](#)
 - Gently resuspend the cell pellet in fresh plating medium and perform a cell count and viability assessment (e.g., using trypan blue). Viability should be >80%.

- Dilute the cells to the desired seeding density (refer to supplier's recommendation, typically $0.3-0.8 \times 10^6$ viable cells/mL).[2]
- Seed the cells onto collagen-coated plates and incubate at 37°C with 5% CO₂.
- After 4-6 hours, replace the medium to remove unattached cells.
- Treatment with Inducers:
 - Culture the hepatocytes for 24-48 hours to allow for monolayer formation.
 - Prepare serial dilutions of CITCO and positive control inducers (Rifampicin for CYP3A4, Phenobarbital for CYP2B6, Omeprazole for CYP1A2) in culture medium. Ensure the final DMSO concentration is consistent and non-toxic (e.g., 0.1%).
 - Aspirate the medium from the cells and add the medium containing the test compounds or vehicle control.
 - Incubate for 24-72 hours. A 48-hour incubation is common for mRNA induction studies.[18]
- RNA Isolation and qRT-PCR:
 - After the incubation period, wash the cells with PBS and lyse them directly in the well using an appropriate lysis buffer.
 - Isolate total RNA according to the manufacturer's protocol.
 - Perform reverse transcription to generate cDNA.
 - Quantify the mRNA expression of target genes (CYP1A2, CYP2B6, CYP3A4) and a housekeeping gene (e.g., GAPDH, ACTB) using qRT-PCR.
 - Calculate the fold induction relative to the vehicle-treated control using the $\Delta\Delta C_t$ method.

Protocol 2: Cytotoxicity Assay

This protocol is used to determine the concentration range at which CITCO is non-toxic to a specific donor lot of hepatocytes.

Materials:

- Plated primary human hepatocytes (as in Protocol 1)
- CITCO
- Culture medium
- Cytotoxicity assay reagent (e.g., MTT, LDH, or a cell viability reagent like PrestoBlue™)
- Plate reader

Procedure:

- Cell Plating: Plate hepatocytes as described in Protocol 1.
- Compound Treatment:
 - Prepare a range of CITCO concentrations in culture medium.
 - Treat the cells with the different concentrations of CITCO for the same duration as the planned induction experiment (e.g., 48 hours). Include a vehicle control and a positive control for cytotoxicity (e.g., a known hepatotoxin).
- Viability Assessment:
 - Following the incubation, perform the chosen cytotoxicity assay according to the manufacturer's instructions.
 - For an MTT assay, this typically involves incubating the cells with the MTT reagent, followed by solubilization of the formazan product and measurement of absorbance.
 - For an LDH assay, a sample of the culture medium is taken to measure the release of lactate dehydrogenase from damaged cells.
- Data Analysis:
 - Calculate the percentage of cell viability relative to the vehicle-treated control.

- Plot the cell viability against the CITCO concentration to determine the concentration at which a significant decrease in viability is observed (e.g., IC50). This will inform the selection of non-toxic concentrations for induction experiments.

Visualizations

Signaling Pathways and Experimental Workflows

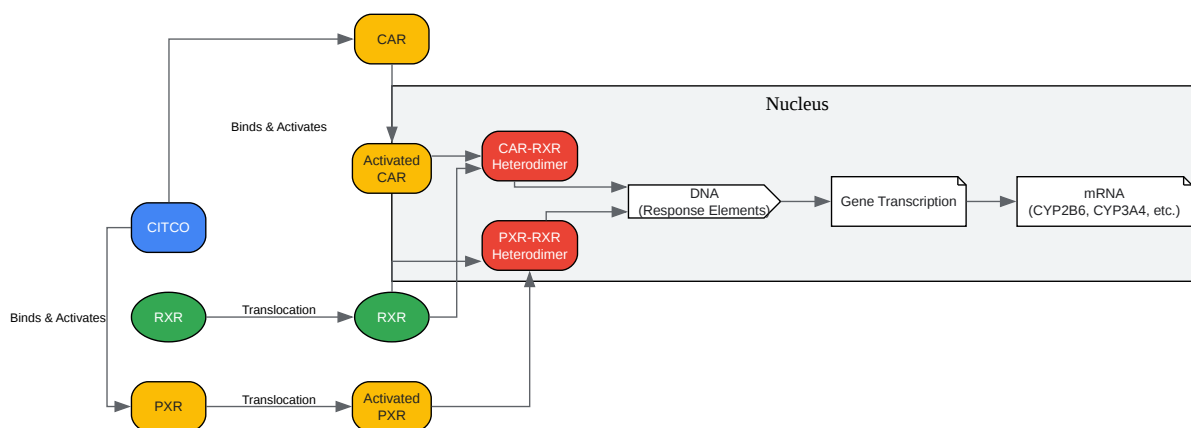

[Click to download full resolution via product page](#)

Caption: CITCO activation of CAR and PXR signaling pathways.

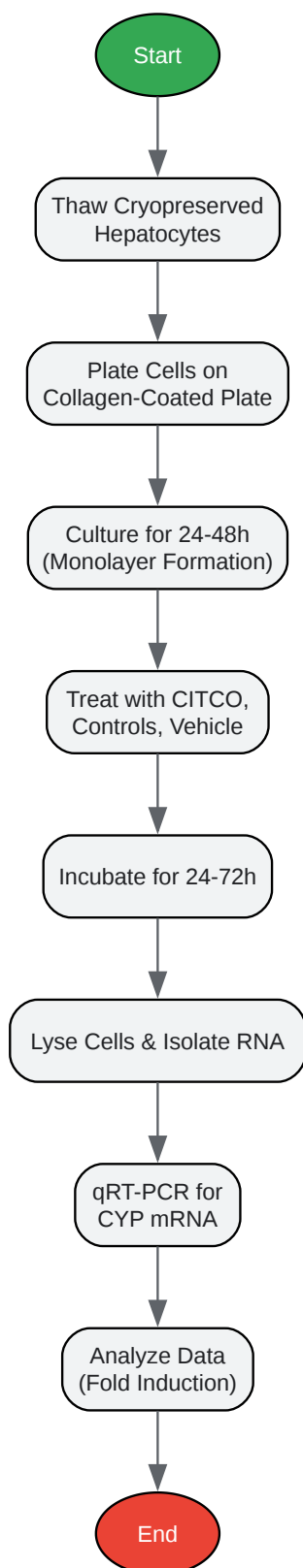

[Click to download full resolution via product page](#)

Caption: Experimental workflow for a CYP450 induction assay.

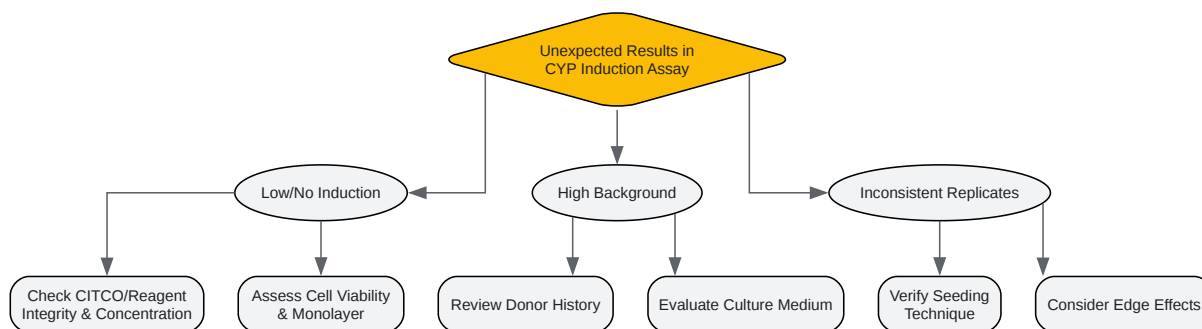

[Click to download full resolution via product page](#)

Need Custom Synthesis?

BenchChem offers custom synthesis for rare earth carbides and specific isotopic labeling.

Email: info@benchchem.com or [Request Quote Online](#).

References

- 1. [news-medical.net](https://www.news-medical.net) [[news-medical.net](https://www.news-medical.net)]
- 2. [bioivt.com](https://www.bioivt.com) [[bioivt.com](https://www.bioivt.com)]
- 3. The potent human CAR activator CITCO is a non-genotoxic hepatic tumour-promoting agent in humanised constitutive androstane receptor mice but not in wild-type animals - PMC [[pmc.ncbi.nlm.nih.gov](https://pubmed.ncbi.nlm.nih.gov/)]
- 4. Regulation of Nuclear Receptors PXR and CAR by Small Molecules and Signal Crosstalk: Roles in Drug Metabolism and Beyond - PMC [[pmc.ncbi.nlm.nih.gov](https://pubmed.ncbi.nlm.nih.gov/)]
- 5. CAR and PXR: The Xenobiotic-Sensing Receptors - PMC [[pmc.ncbi.nlm.nih.gov](https://pubmed.ncbi.nlm.nih.gov/)]
- 6. [mdpi.com](https://www.mdpi.com) [[mdpi.com](https://www.mdpi.com)]
- 7. CITCO Directly Binds to and Activates Human Pregnane X Receptor - PMC [[pmc.ncbi.nlm.nih.gov](https://pubmed.ncbi.nlm.nih.gov/)]
- 8. [researchgate.net](https://www.researchgate.net) [[researchgate.net](https://www.researchgate.net)]

- [9. researchgate.net \[researchgate.net\]](#)
- [10. researchgate.net \[researchgate.net\]](#)
- [11. researchgate.net \[researchgate.net\]](#)
- [12. Effect of Donor Age and Liver Steatosis on Potential of Decellularized Liver Matrices to be Used as a Platform for iPSC-Hepatocyte Culture - PMC \[pmc.ncbi.nlm.nih.gov\]](#)
- [13. Considerations for developing CYP induction assays in hepatocytes: Insights from a multilaboratory study - PubMed \[pubmed.ncbi.nlm.nih.gov\]](#)
- [14. aminer.org \[aminer.org\]](#)
- [15. Thawing and Plating Cryopreserved Hepatocytes | Thermo Fisher Scientific - HK \[thermofisher.com\]](#)
- [16. Inhlifesciences.org \[Inhlifesciences.org\]](#)
- [17. Primary Human Hepatocytes Culture Protocol \[sigmaaldrich.com\]](#)
- [18. xenotech.com \[xenotech.com\]](#)
- [19. indigobiosciences.com \[indigobiosciences.com\]](#)
- [20. researchportal.hw.ac.uk \[researchportal.hw.ac.uk\]](#)
- [21. jstage.jst.go.jp \[jstage.jst.go.jp\]](#)
- [22. cdn.prod.website-files.com \[cdn.prod.website-files.com\]](#)
- To cite this document: BenchChem. [Technical Support Center: Managing Variability in CITCO Response Between Hepatocyte Donors]. BenchChem, [2026]. [Online PDF]. Available at: [<https://www.benchchem.com/product/b1238009/docs#technical-support-center-managing-variability-in-citco-response-between-hepatocyte-donors>]

Disclaimer & Data Validity:

The information provided in this document is for Research Use Only (RUO) and is strictly not intended for diagnostic or therapeutic procedures. While BenchChem strives to provide accurate protocols, we make no warranties, express or implied, regarding the fitness of this product for every specific experimental setup.

Technical Support: The protocols provided are for reference purposes. Unsure if this reagent suits your experiment?

Need Industrial/Bulk Grade? [Request Custom Synthesis Quote](#)

BenchChem

Our mission is to be the trusted global source of essential and advanced chemicals, empowering scientists and researchers to drive progress in science and industry.

Contact

Address: 3281 E Guasti Rd

Ontario, CA 91761, United States

Phone: (601) 213-4426

Email: info@benchchem.com

[Contact our Ph.D. Support Team for a compatibility check](#)