

Rigosertib vs. Standard-of-Care in Pancreatic Cancer Models: A Comparative Efficacy Guide

Author: BenchChem Technical Support Team. **Date:** December 2025

Compound of Interest

Compound Name: *Rigosertib*

Cat. No.: *B1238547*

[Get Quote](#)

For Researchers, Scientists, and Drug Development Professionals

This guide provides a comparative analysis of the investigational drug **Rigosertib** against standard-of-care therapies in preclinical and clinical pancreatic cancer models. While direct head-to-head preclinical studies with comprehensive quantitative data are limited in publicly available literature, this document synthesizes the existing evidence to offer insights into their relative efficacy and mechanisms of action.

Executive Summary

Pancreatic cancer remains a significant therapeutic challenge. Standard-of-care regimens, such as those involving gemcitabine and the combination therapy FOLFIRINOX (5-fluorouracil, leucovorin, irinotecan, and oxaliplatin), provide modest benefits. **Rigosertib**, a multi-kinase inhibitor, has been investigated as a novel therapeutic agent. Preclinical studies suggested potential efficacy, particularly in combination with gemcitabine and in treatment-resistant scenarios. However, these promising preclinical signals did not translate into improved survival benefits in a pivotal Phase II/III clinical trial. This guide will delve into the available data to provide a nuanced comparison.

Mechanism of Action: Rigosertib

Rigosertib is a styryl-benzyl-sulfone that acts as a multi-kinase inhibitor. Its primary targets are Polo-like kinase 1 (PLK1) and Phosphoinositide 3-kinase (PI3K).^{[1][2]}

- **PLK1 Inhibition:** PLK1 is a critical regulator of multiple stages of mitosis. Its inhibition by **Rigosertib** leads to mitotic arrest and subsequent apoptosis in rapidly dividing cancer cells. [\[3\]](#)[\[4\]](#)
- **PI3K Inhibition:** The PI3K/AKT/mTOR pathway is a key signaling cascade that promotes cell survival, proliferation, and growth. By inhibiting PI3K, **Rigosertib** can suppress these pro-tumorigenic signals. [\[1\]](#)[\[2\]](#)
- **RAS Mimetic Activity:** Some studies suggest that **Rigosertib** may also function as a RAS mimetic, interfering with RAS-effector protein interactions and thereby inhibiting downstream signaling through pathways like the RAF-MEK-ERK cascade. [\[2\]](#)

The multi-targeted nature of **Rigosertib** theoretically offers a comprehensive approach to inhibiting cancer cell proliferation and survival.

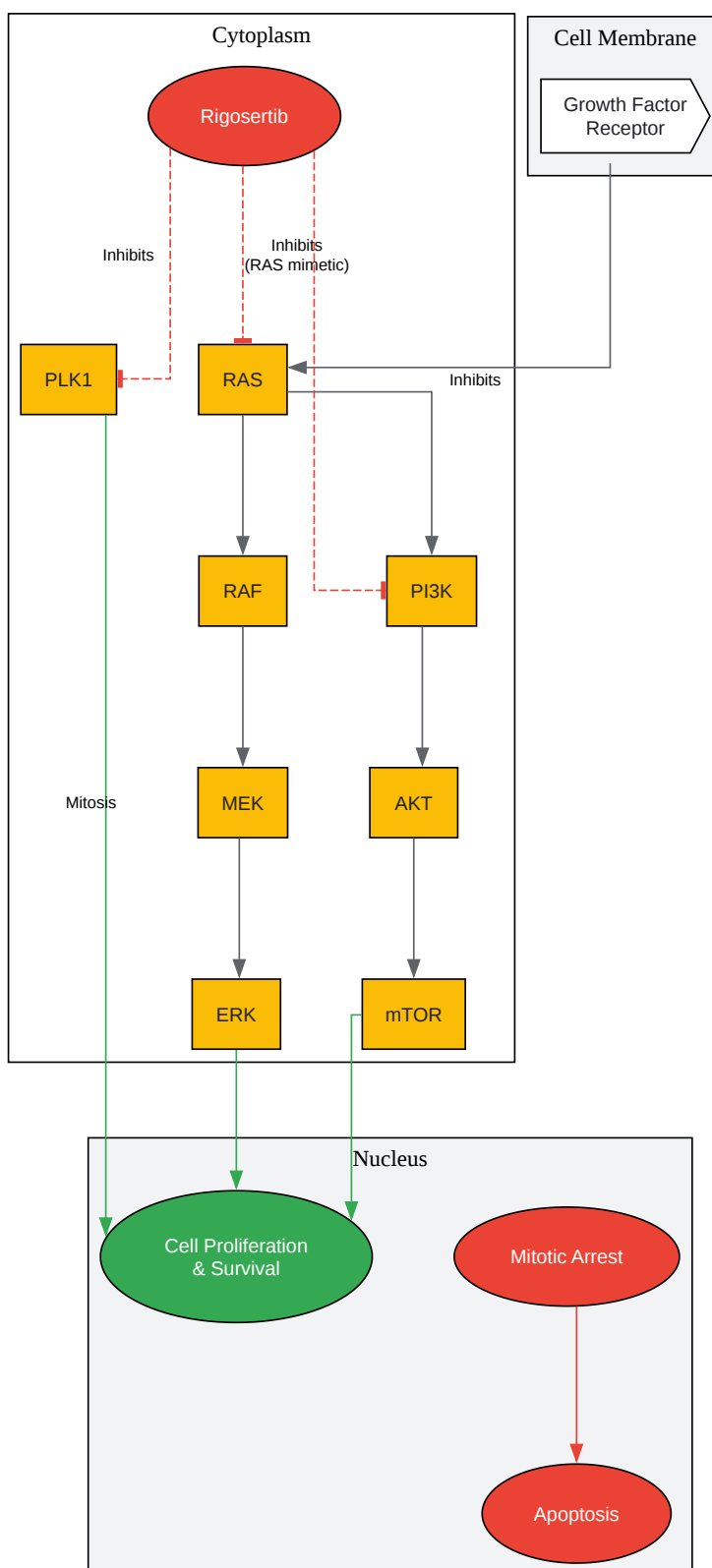

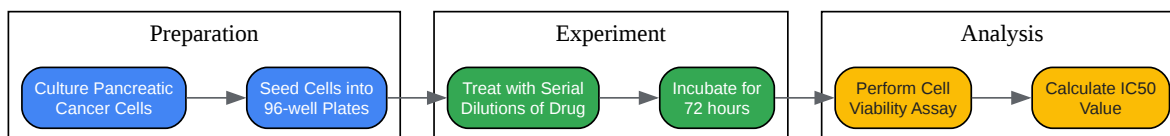

[Click to download full resolution via product page](#)

Need Custom Synthesis?

BenchChem offers custom synthesis for rare earth carbides and specific isotopic labeling.

Email: info@benchchem.com or [Request Quote Online](#).

References

- 1. Preclinical Study Examines Novel Pancreatic Cancer Treatment - The ASCO Post [ascopost.com]
- 2. Genetically defined subsets of human pancreatic cancer demonstrate unique in vitro chemosensitivity - PMC [pmc.ncbi.nlm.nih.gov]
- 3. Anti-tumor effects of rigosertib in high-risk neuroblastoma - PMC [pmc.ncbi.nlm.nih.gov]
- 4. New drug stops rushing cancer cells, slow and steady healthy cells unharmed - ecancer [ecancer.org]
- To cite this document: BenchChem. [Rigosertib vs. Standard-of-Care in Pancreatic Cancer Models: A Comparative Efficacy Guide]. BenchChem, [2025]. [Online PDF]. Available at: [https://www.benchchem.com/product/b1238547#comparing-the-efficacy-of-rigosertib-versus-standard-of-care-in-pancreatic-cancer-models]

Disclaimer & Data Validity:

The information provided in this document is for Research Use Only (RUO) and is strictly not intended for diagnostic or therapeutic procedures. While BenchChem strives to provide accurate protocols, we make no warranties, express or implied, regarding the fitness of this product for every specific experimental setup.

Technical Support: The protocols provided are for reference purposes. Unsure if this reagent suits your experiment? [[Contact our Ph.D. Support Team for a compatibility check](#)]

Need Industrial/Bulk Grade? [Request Custom Synthesis Quote](#)

BenchChem

Our mission is to be the trusted global source of essential and advanced chemicals, empowering scientists and researchers to drive progress in science and industry.

Contact

Address: 3281 E Guasti Rd

Ontario, CA 91761, United States

Phone: (601) 213-4426

Email: info@benchchem.com