

Diphthamide Deficiency Syndromes: A Technical Guide for Researchers and Drug Development Professionals

Author: BenchChem Technical Support Team. **Date:** April 2026

Compound of Interest

Compound Name: *Diphthamide*

Cat. No.: *B1238258*

[Get Quote](#)

An In-depth Exploration of the Molecular Underpinnings, Associated Pathologies, and Experimental Methodologies

Introduction

Diphthamide is a unique and highly conserved post-translational modification of a specific histidine residue on eukaryotic and archaeal translation elongation factor 2 (eEF2). This complex modification plays a crucial role in maintaining translational fidelity and ensuring the accuracy of protein synthesis. The biosynthesis of **diphthamide** is a multi-step enzymatic process involving a cohort of at least seven highly conserved proteins, encoded by the DPH genes (DPH1-DPH7). Genetic mutations in these genes can lead to a group of rare, autosomal recessive disorders collectively known as **diphthamide** deficiency syndromes. These syndromes are characterized by a range of severe clinical manifestations, primarily affecting neurodevelopment. This technical guide provides a comprehensive overview of **diphthamide** biosynthesis, the molecular basis of its deficiency syndromes, associated human diseases, and detailed experimental protocols for their study.

The Diphthamide Biosynthesis Pathway

The formation of **diphthamide** on eEF2 is a sophisticated four-step enzymatic cascade that utilizes S-adenosylmethionine (SAM) as a key substrate. The pathway is essential for the proper functioning of eEF2 in ribosomal translocation during protein synthesis.

Step 1: ACP Radical Transfer

The initial step involves the transfer of a 3-amino-3-carboxypropyl (ACP) group from SAM to the C-2 position of the imidazole ring of a conserved histidine residue (His715 in human eEF2). This reaction is catalyzed by a heterodimeric radical SAM enzyme complex composed of DPH1 and DPH2.^{[1][2][3]} This process requires the presence of iron-sulfur ([4Fe-4S]) clusters within both DPH1 and DPH2 and is facilitated by DPH3 and DPH4, which are thought to be involved in electron donation to maintain the redox state of the DPH1/DPH2 complex.^{[1][4]}

Step 2: Methylation

Following the addition of the ACP group, the intermediate undergoes four successive methylation reactions, catalyzed by the methyltransferase DPH5.^{[5][6][7][8][9]} This results in the formation of a methylated diphthine intermediate.^[10]

Step 3: Demethylation

A previously overlooked step in the pathway involves the demethylation of the methylated diphthine intermediate to yield diphthine. This hydrolysis reaction is catalyzed by DPH7, which functions as a methylesterase.^[10]

Step 4: Amidation

The final step is the ATP-dependent amidation of the carboxyl group of diphthine to form the mature **diphthamide** modification. This reaction is catalyzed by the **diphthamide** synthetase, DPH6.^{[4][11][12][13]} DPH7 also plays a regulatory role in this step, potentially by promoting the dissociation of DPH5 from eEF2, thereby allowing DPH6 access to the diphthine intermediate.^{[4][13]}

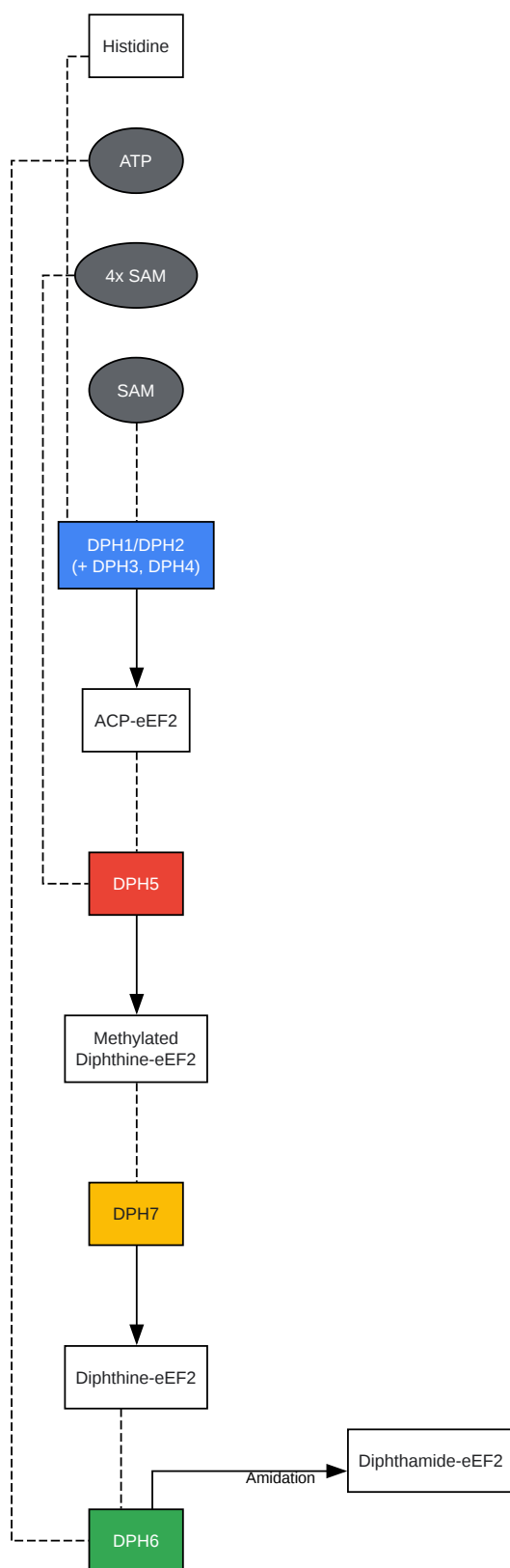

[Click to download full resolution via product page](#)

Figure 1: The **Diphthamide** Biosynthesis Pathway.

Diphthamide Deficiency Syndromes and Associated Human Diseases

Mutations in the DPH genes that impair the biosynthesis of **diphthamide** lead to a spectrum of rare autosomal recessive neurodevelopmental disorders.[14][15] Clinical deficiencies have been primarily described for mutations in DPH1, DPH2, and DPH5.[15][16][17][18] Complete loss of **diphthamide** synthesis is embryonically lethal in mice, suggesting that the mutations found in patients result in reduced, but not completely abolished, enzyme function.[14]

The clinical presentation of **diphthamide** deficiency syndromes is heterogeneous but typically includes:

- Intellectual disability and developmental delay[14][19][20][21][22]
- Short stature[14][19][20][22]
- Craniofacial abnormalities[19][20][21][22]
- Ectodermal anomalies, such as sparse hair[20][22]
- Seizures[21]
- Congenital heart defects[14]

The molecular basis for these pathologies lies in the compromised function of eEF2.

Diphthamide is critical for maintaining translational fidelity by preventing ribosomal frameshifting.[23][24][25][26][27] Its absence leads to an increased rate of -1 frameshifting, resulting in the production of aberrant proteins and cellular stress.[23][25]

Quantitative Data on Diphthamide Deficiency

Parameter	Observation	References
Ribosomal Frameshifting	Loss of diphthamide modification leads to a ~1.5 to 2-fold increase in -1 ribosomal frameshifting at programmed viral frameshifting sites.	[23][25]
Disease Association	Biallelic loss-of-function variants in DPH1, DPH2, and DPH5 are associated with severe syndromic neurodevelopmental disorders.	[15][16][17][18]
Prevalence	Diphthamide deficiency syndromes are considered ultra-rare disorders. Pathogenic variants are listed in databases such as gnomAD.	[15][28]

Diphthamide and Cancer

The role of **diphthamide** biosynthesis in cancer is complex and appears to be context-dependent. DPH1 was initially identified as a candidate tumor suppressor gene in ovarian cancer.[14] However, other studies have suggested an oncogenic role for DPH1 in colorectal cancer.[29] The expression levels of DPH genes can also influence the sensitivity of cancer cells to certain immunotoxins that utilize diphtheria toxin as a payload.

Cancer Type	Gene	Observation	References
Ovarian Cancer	DPH1	Initially identified as a candidate tumor suppressor gene.	[14]
TP53, BRCA1/2, PIK3CA, KRAS	Most commonly mutated genes in high-grade serous ovarian carcinoma.	[30][31]	
Colorectal Cancer	DPH1	Increased protein and mRNA levels observed in CRC tissues compared to noncancerous tissues, suggesting an oncogenic role.	[29]

Experimental Protocols

A variety of in vitro and cell-based assays are utilized to study **diphthamide** biosynthesis and the functional consequences of its deficiency.

ADP-Ribosylation Assay

This assay is a cornerstone for detecting the presence of **diphthamide** on eEF2. Diphtheria toxin (DT) specifically catalyzes the transfer of an ADP-ribose group from nicotinamide adenine dinucleotide (NAD⁺) to the **diphthamide** residue. By using a labeled NAD⁺ analog (e.g., biotin-NAD⁺), the ADP-ribosylated eEF2 can be detected.

Methodology:

- Cell Lysate Preparation:
 - Harvest cells and wash with ice-cold PBS.
 - Lyse cells in a suitable lysis buffer (e.g., RIPA buffer) containing protease inhibitors.

- Centrifuge to pellet cell debris and collect the supernatant containing the protein lysate.
- Determine the protein concentration of the lysate.
- ADP-Ribosylation Reaction:
 - In a microcentrifuge tube, combine a standardized amount of protein lysate (e.g., 50 μg) with ADP-ribosylation buffer (20 mM Tris-HCl, pH 7.4; 1 mM EDTA; 50 mM DTT).
 - Add diphtheria toxin (e.g., 100 ng) and biotinylated NAD⁺ (e.g., 5 μM).
 - Incubate the reaction mixture at 25°C for 30 minutes.
- Detection:
 - Stop the reaction by adding SDS-PAGE loading buffer and boiling the samples.
 - Separate the proteins by SDS-PAGE and transfer them to a nitrocellulose or PVDF membrane.
 - Block the membrane and then probe with a streptavidin-horseradish peroxidase (HRP) conjugate to detect the biotinylated, ADP-ribosylated eEF2.
 - Visualize the signal using a chemiluminescent substrate.

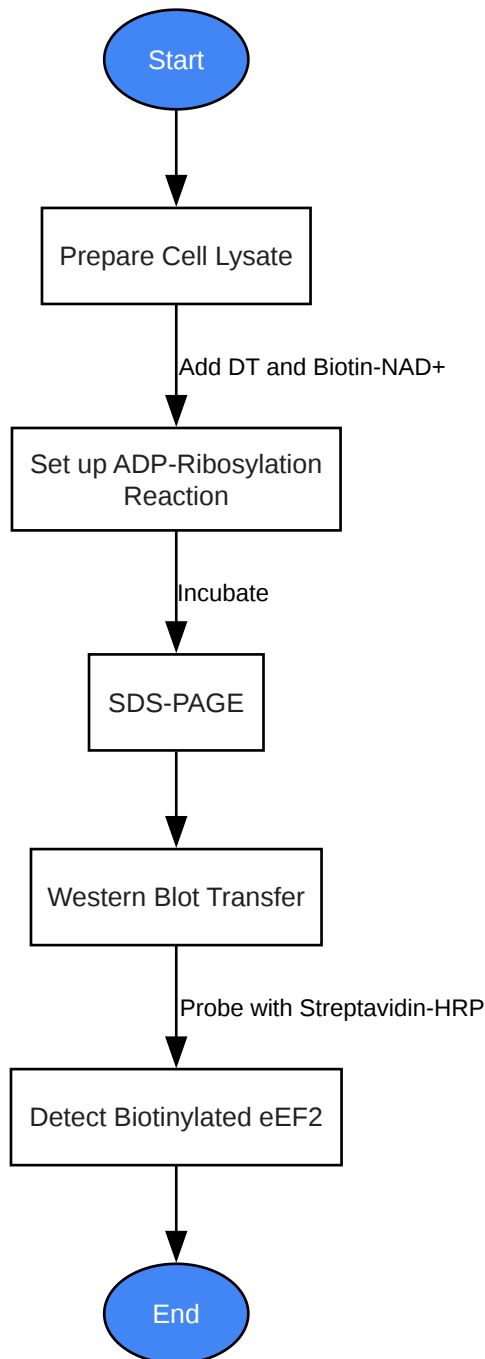

[Click to download full resolution via product page](#)

Figure 2: Experimental Workflow for ADP-Ribosylation Assay.

Western Blotting for Unmodified eEF2

Specific antibodies are available that can distinguish between total eEF2 and eEF2 that lacks the **diphthamide** modification. This allows for the direct assessment of the **diphthamide** status

in cell lysates.

Methodology:

- Sample Preparation and Electrophoresis:
 - Prepare protein lysates from cells as described for the ADP-ribosylation assay.
 - Separate the proteins by SDS-PAGE.
- Protein Transfer:
 - Transfer the separated proteins to a nitrocellulose or PVDF membrane.
- Immunodetection:
 - Block the membrane to prevent non-specific antibody binding.
 - Incubate the membrane with a primary antibody specific for unmodified eEF2.
 - As a loading control, a parallel blot or the same blot after stripping can be incubated with a primary antibody that recognizes total eEF2 (pan-eEF2).
 - Wash the membrane and incubate with an appropriate HRP-conjugated secondary antibody.
 - Visualize the signal using a chemiluminescent substrate.

Cell Viability (MTT) Assay for Diphtheria Toxin Sensitivity

This assay measures the cytotoxic effect of diphtheria toxin on cells, which is dependent on the presence of **diphthamide**. Cells with a functional **diphthamide** biosynthesis pathway will be sensitive to DT, while deficient cells will be resistant.

Methodology:

- Cell Seeding:

- Seed cells in a 96-well plate at a predetermined density and allow them to adhere overnight.
- Toxin Treatment:
 - Treat the cells with serial dilutions of diphtheria toxin. Include untreated control wells.
 - Incubate the plate for a specified period (e.g., 48-72 hours).
- MTT Addition and Incubation:
 - Add MTT (3-(4,5-dimethylthiazol-2-yl)-2,5-diphenyltetrazolium bromide) solution to each well and incubate for 2-4 hours at 37°C. Metabolically active cells will reduce the yellow MTT to purple formazan crystals.
- Solubilization and Absorbance Reading:
 - Add a solubilization solution (e.g., DMSO or a specialized reagent) to dissolve the formazan crystals.
 - Measure the absorbance at a wavelength of 570 nm using a microplate reader.
- Data Analysis:
 - Calculate cell viability as a percentage of the untreated control and plot a dose-response curve to determine the IC50 value (the concentration of toxin that inhibits cell viability by 50%).

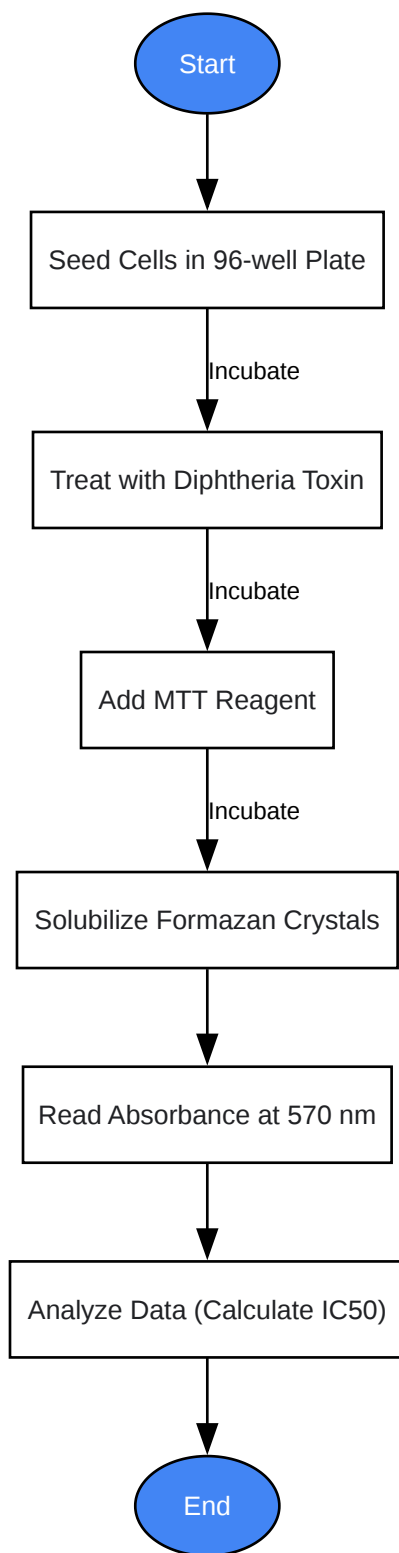

[Click to download full resolution via product page](#)

Figure 3: Experimental Workflow for MTT Cytotoxicity Assay.

Conclusion

Diphthamide deficiency syndromes represent a class of severe, ultra-rare genetic disorders with significant unmet medical needs. A thorough understanding of the intricate **diphthamide** biosynthesis pathway and the functional consequences of its disruption is paramount for the development of diagnostic tools and potential therapeutic interventions. The experimental protocols detailed in this guide provide a robust framework for researchers and drug development professionals to investigate the molecular mechanisms of these devastating diseases and to explore novel therapeutic strategies. Further research into the precise roles of **diphthamide** in cellular processes will undoubtedly shed more light on its importance in human health and disease.

Need Custom Synthesis?

BenchChem offers custom synthesis for rare earth carbides and specific isotopic labeling.

Email: info@benchchem.com or [Request Quote Online](#).

References

- [1. researchgate.net \[researchgate.net\]](#)
- [2. Functional Integrity of Radical SAM Enzyme Dph1•Dph2 Requires Non-Canonical Cofactor Motifs with Tandem Cysteines - PMC \[pmc.ncbi.nlm.nih.gov\]](#)
- [3. The asymmetric function of Dph1-Dph2 heterodimer in diphthamide biosynthesis - PMC \[pmc.ncbi.nlm.nih.gov\]](#)
- [4. Decoding the biosynthesis and function of diphthamide, an enigmatic modification of translation elongation factor 2 \(EF2\) - PMC \[pmc.ncbi.nlm.nih.gov\]](#)
- [5. genecards.org \[genecards.org\]](#)
- [6. platform.opentargets.org \[platform.opentargets.org\]](#)
- [7. DPH5, a methyltransferase gene required for diphthamide biosynthesis in Saccharomyces cerevisiae - PubMed \[pubmed.ncbi.nlm.nih.gov\]](#)
- [8. Reactome | DPH5 transfers four methyl groups from AdoMet to aminocarboxypropyl EEF2 \[reactome.org\]](#)
- [9. DPH5 - Wikipedia \[en.wikipedia.org\]](#)

- 10. Dph7 Catalyzes a Previously Unknown Demethylation Step in Diphthamide Biosynthesis - PMC [[pmc.ncbi.nlm.nih.gov](https://pubmed.ncbi.nlm.nih.gov/)]
- 11. The Amidation Step of Diphthamide Biosynthesis in Yeast Requires DPH6, a Gene Identified through Mining the DPH1-DPH5 Interaction Network | PLOS Genetics [journals.plos.org]
- 12. The Amidation Step of Diphthamide Biosynthesis in Yeast Requires DPH6, a Gene Identified through Mining the DPH1-DPH5 Interaction Network - PMC [[pmc.ncbi.nlm.nih.gov](https://pubmed.ncbi.nlm.nih.gov/)]
- 13. Decoding the biosynthesis and function of diphthamide, an enigmatic modification of translation elongation factor 2 (EF2) - PubMed [pubmed.ncbi.nlm.nih.gov]
- 14. Diphthamide-deficiency syndrome: a novel human developmental disorder and ribosomopathy - PMC [[pmc.ncbi.nlm.nih.gov](https://pubmed.ncbi.nlm.nih.gov/)]
- 15. DPH1 and DPH2 variants that confer susceptibility to diphthamide deficiency syndrome in human cells and yeast models - PMC [[pmc.ncbi.nlm.nih.gov](https://pubmed.ncbi.nlm.nih.gov/)]
- 16. diseases.jensenlab.org [diseases.jensenlab.org]
- 17. diseases.jensenlab.org [diseases.jensenlab.org]
- 18. Expanding the Phenotypic Spectrum Associated with DPH5-Related Diphthamide Deficiency [mdpi.com]
- 19. Matching two independent cohorts validates DPH1 as a gene responsible for autosomal recessive intellectual disability with short stature, craniofacial, and ectodermal anomalies - PubMed [pubmed.ncbi.nlm.nih.gov]
- 20. DPH1 syndrome: two novel variants and structural and functional analyses of seven missense variants identified in syndromic patients - PMC [[pmc.ncbi.nlm.nih.gov](https://pubmed.ncbi.nlm.nih.gov/)]
- 21. researchgate.net [researchgate.net]
- 22. Monarch Initiative [beta.monarchinitiative.org]
- 23. academic.oup.com [academic.oup.com]
- 24. eEF2 diphthamide modification restrains spurious frameshifting to maintain translational fidelity - PubMed [pubmed.ncbi.nlm.nih.gov]
- 25. eEF2 diphthamide modification restrains spurious frameshifting to maintain translational fidelity - PMC [[pmc.ncbi.nlm.nih.gov](https://pubmed.ncbi.nlm.nih.gov/)]
- 26. pubs.acs.org [pubs.acs.org]
- 27. researchgate.net [researchgate.net]
- 28. DPH1 and DPH2 variants that confer susceptibility to diphthamide deficiency syndrome in human cells and yeast models - PubMed [pubmed.ncbi.nlm.nih.gov]

- [29. MTT Assay Protocol for Cell Viability and Proliferation \[merckmillipore.com\]](#)
- [30. Cellular Mechanism of Gene Mutations and Potential Therapeutic Targets in Ovarian Cancer - PMC \[pmc.ncbi.nlm.nih.gov\]](#)
- [31. Most Commonly Mutated Genes in High-Grade Serous Ovarian Carcinoma Are Nonessential for Ovarian Surface Epithelial Stem Cell Transformation - PMC \[pmc.ncbi.nlm.nih.gov\]](#)
- To cite this document: BenchChem. [Diphthamide Deficiency Syndromes: A Technical Guide for Researchers and Drug Development Professionals]. BenchChem, [2026]. [Online PDF]. Available at: [<https://www.benchchem.com/product/b1238258/docs#diphthamide-deficiency-syndromes-a-technical-guide-for-researchers-and-drug-development-professionals>]

Disclaimer & Data Validity:

The information provided in this document is for Research Use Only (RUO) and is strictly not intended for diagnostic or therapeutic procedures. While BenchChem strives to provide accurate protocols, we make no warranties, express or implied, regarding the fitness of this product for every specific experimental setup.

Technical Support: The protocols provided are for reference purposes. Unsure if this reagent suits your experiment?

Need Industrial/Bulk Grade? [Request Custom Synthesis Quote](#)

BenchChem

Our mission is to be the trusted global source of essential and advanced chemicals, empowering scientists and researchers to drive progress in science and industry.

Contact

Address: 3281 E Guasti Rd
Ontario, CA 91761, United States
Phone: (601) 213-4426
Email: info@benchchem.com

Contact our Ph.D. Support Team for a compatibility check