

# Application Note: Quantification of Arachidyl Oleate in Complex Biological Samples

**Author:** BenchChem Technical Support Team. **Date:** April 2026

## Compound of Interest

Compound Name: Arachidyl oleate

CAS No.: 22393-88-0

Cat. No.: B1238231

[Get Quote](#)

For Researchers, Scientists, and Drug Development Professionals

## Introduction

**Arachidyl oleate** (C20:0/18:1) is a wax ester, a class of neutral lipids composed of a long-chain fatty acid esterified to a long-chain fatty alcohol.[1] In humans, wax esters are significant components of sebum, the lipid-rich secretion of the sebaceous glands that coats the skin and hair, contributing to its barrier function and hydration.[2][3] Specifically, wax esters can constitute up to 26% of total lipids in human sebum.[2] The analysis of specific wax esters like **arachidyl oleate** in biological matrices such as sebum or other skin lipid extracts is crucial for dermatological research, cosmetics development, and understanding skin disorders. This application note provides detailed protocols for the quantification of **arachidyl oleate** in complex biological samples using Gas Chromatography-Mass Spectrometry (GC-MS) and Liquid Chromatography-Tandem Mass Spectrometry (LC-MS/MS).

## Data Presentation: Quantitative Composition of Wax Esters in Human Sebum

While the exact concentration of **Arachidyl oleate** can vary between individuals, the following table summarizes the relative composition of major wax ester classes found in human sebum. [2] This provides a reference for the expected distribution of related analytes in a typical sebum sample.

Lipid Class	Percentage of Total Lipids	Key Components
Wax Esters	~26%	Saturated and monounsaturated fatty acids and alcohols ranging from C14 to C22.
Triglycerides & Free Fatty Acids	~57.5%	Palmitic acid (16:0), Oleic acid (18:1), Sapienic acid (16:1n-10)
Squalene	~12%	Squalene
Cholesterol & Cholesterol Esters	~4.5%	Cholesterol

Table 1: General Composition of Human Sebum Lipids.

The following table details the relative abundance of different chain length combinations in the wax ester fraction of human meibum, a related lipid secretion from the eyelid's meibomian glands. This provides an insight into the diversity of wax esters that may be encountered.

Wax Ester (Fatty Acid:Fatty Alcohol)	Relative Abundance (%)
18:1 / 24:0	12.5
18:1 / 25:0	10.2
18:1 / 26:0	8.5
16:1 / 24:0	7.1
18:0 / 25:0	6.8
Other species including C20 alcohols	Variable

Table 2: Example of relative abundance of major wax ester species in human meibomian gland secretions. Note that arachidyl (20:0) alcohol containing species are also detected.

## Experimental Protocols

### Sample Collection and Lipid Extraction

This protocol is optimized for the extraction of total lipids, including wax esters, from a sebum sample collected using a Sebutape™ or similar absorbent patch.

Materials:

- Sebutape™ patch with collected sebum
- Chloroform
- Methanol
- Deionized water
- Glass vials with PTFE-lined caps
- Vortex mixer
- Centrifuge
- Nitrogen gas stream evaporator

Procedure:

- Cut the Sebutape™ into small pieces and place them in a glass vial.
- Add 2 mL of a chloroform:methanol (2:1, v/v) solvent mixture to the vial.
- Vortex vigorously for 2 minutes to extract the lipids.
- Add 0.5 mL of deionized water to the vial to induce phase separation.
- Vortex for 1 minute and then centrifuge at 2000 x g for 10 minutes to separate the layers.

- Carefully collect the lower organic phase (chloroform layer) containing the lipids using a glass Pasteur pipette and transfer it to a clean vial.
- Dry the extracted lipids under a gentle stream of nitrogen gas.
- Resuspend the dried lipid extract in a known volume of an appropriate solvent (e.g., hexane for GC-MS or a mobile phase compatible solvent for LC-MS/MS) for analysis.

## Quantification by Gas Chromatography-Mass Spectrometry (GC-MS)

For GC-MS analysis, intact wax esters can be analyzed at high temperatures. Alternatively, they can be transesterified to fatty acid methyl esters (FAMES) and fatty alcohols, which are then analyzed separately. The following protocol describes the analysis of intact wax esters.

Instrumentation and Conditions:

- Gas Chromatograph: Agilent 8890 GC (or equivalent)
- Mass Spectrometer: 7010B Triple Quadrupole GC/MS (or equivalent)
- Column: DB-1MS, 30 m x 250  $\mu$ m x 0.25  $\mu$ m (or a similar high-temperature capillary column)
- Carrier Gas: Helium at a constant flow of 1.5 mL/min
- Injector Temperature: 325°C
- Injection Mode: Splitless
- Oven Temperature Program: Initial temperature of 50°C for 2 minutes, then ramp at 40°C/min to 200°C, then ramp at 3°C/min to 320°C and hold for 10 minutes.
- MS Transfer Line Temperature: 310°C
- Ion Source Temperature: 230°C
- Ionization Mode: Electron Ionization (EI) at 70 eV

- Scan Range: m/z 40-850

#### Sample Preparation for GC-MS:

- Reconstitute the dried lipid extract in 100  $\mu$ L of hexane.
- Transfer the sample to a GC vial with a micro-insert.
- Inject 1  $\mu$ L of the sample into the GC-MS.

Data Analysis: Quantification is achieved by creating a calibration curve using an authentic **Arachidyl oleate** standard. The peak area of the molecular ion or a characteristic fragment ion is plotted against the concentration of the standard.

## Quantification by Liquid Chromatography-Tandem Mass Spectrometry (LC-MS/MS)

LC-MS/MS allows for the analysis of intact wax esters without the need for derivatization and at lower temperatures than GC-MS.

#### Instrumentation and Conditions:

- Liquid Chromatograph: Agilent 1290 HPLC (or equivalent)
- Mass Spectrometer: Agilent 6520 QTOF-MS (or a triple quadrupole mass spectrometer)
- Column: Agilent Poroshell 120 EC-C18, 100 mm x 3.0 mm, 2.7  $\mu$ m
- Column Temperature: 50°C
- Mobile Phase A: 80:20 water:2-propanol with 25  $\mu$ M ammonium formate
- Mobile Phase B: 80:10:10 butanol:water:2-propanol with 25  $\mu$ M ammonium formate
- Gradient: 30% B to 100% B over 24 minutes
- Flow Rate: 0.25 mL/min

- Ionization Mode: Positive Electrospray Ionization (ESI+)
- Nebulizer Pressure: 30 psig
- Drying Gas Temperature: 325°C
- Drying Gas Flow: 4 L/min
- MS/MS Analysis: Use Multiple Reaction Monitoring (MRM) on a triple quadrupole instrument. For **Arachidyl oleate** (MW = 562.99), monitor the transition of the precursor ion (e.g.,  $[M+NH_4]^+$  at  $m/z$  580.6) to a product ion corresponding to the fatty acid or fatty alcohol moiety. A characteristic fragment for oleic acid is often observed.

#### Sample Preparation for LC-MS/MS:

- Reconstitute the dried lipid extract in 100  $\mu$ L of a solvent compatible with the initial mobile phase conditions (e.g., 9:1 methanol:toluene).
- Centrifuge the sample to pellet any insoluble material.
- Transfer the supernatant to an LC vial.
- Inject 5-10  $\mu$ L of the sample into the LC-MS/MS system.

Data Analysis: Quantification is performed using a calibration curve prepared with an authentic **Arachidyl oleate** standard. The peak area of the selected MRM transition is plotted against the concentration of the standard.

## Visualizations

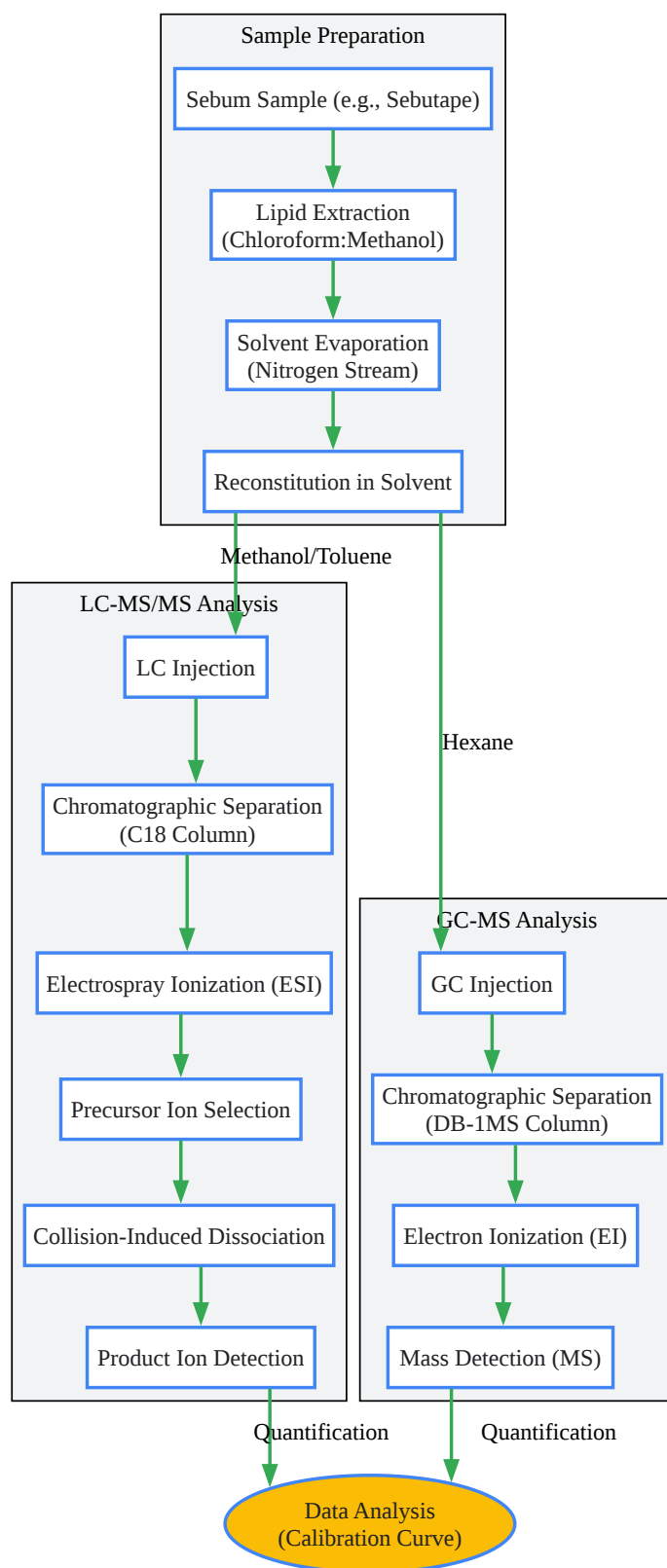

[Click to download full resolution via product page](#)

Caption: Experimental workflow for the quantification of **Arachidyl oleate**.

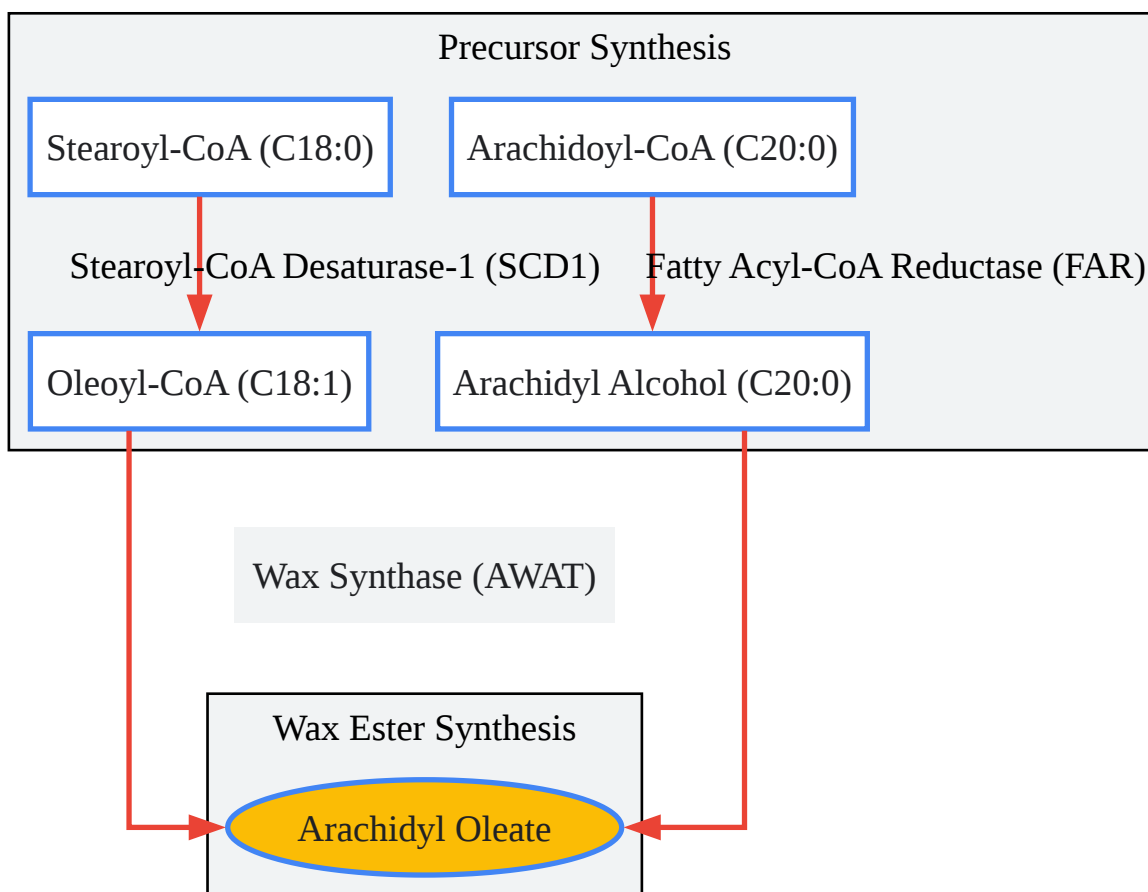

[Click to download full resolution via product page](#)

Caption: Biosynthetic pathway of **Arachidyl oleate**.

### Need Custom Synthesis?

BenchChem offers custom synthesis for rare earth carbides and specific isotopic labeling.

Email: [info@benchchem.com](mailto:info@benchchem.com) or [Request Quote Online](#).

## References

- 1. Wax esters | Cyberlipid [[cyberlipid.gerli.com](http://cyberlipid.gerli.com)]
- 2. Sebaceous gland lipids - PMC [[pmc.ncbi.nlm.nih.gov](http://pmc.ncbi.nlm.nih.gov)]
- 3. Wax Esters Analysis Service - Lipidomics|Creative Proteomics [[lipidomics.creative-proteomics.com](http://lipidomics.creative-proteomics.com)]

- To cite this document: BenchChem. [Application Note: Quantification of Arachidyl Oleate in Complex Biological Samples]. BenchChem, [2026]. [Online PDF]. Available at: [<https://www.benchchem.com/product/b1238231/docs#application-note-quantification-of-arachidyl-oleate-in-complex-biological-samples>]

---

### Disclaimer & Data Validity:

The information provided in this document is for Research Use Only (RUO) and is strictly not intended for diagnostic or therapeutic procedures. While BenchChem strives to provide accurate protocols, we make no warranties, express or implied, regarding the fitness of this product for every specific experimental setup.

**Technical Support:** The protocols provided are for reference purposes. Unsure if this reagent suits your experiment?

**Need Industrial/Bulk Grade?** [Request Custom Synthesis Quote](#)

## BenchChem

Our mission is to be the trusted global source of essential and advanced chemicals, empowering scientists and researchers to drive progress in science and industry.

### Contact

Address: 3281 E Guasti Rd  
Ontario, CA 91761, United States  
Phone: (601) 213-4426  
Email: [info@benchchem.com](mailto:info@benchchem.com)

[Contact our Ph.D. Support Team for a compatibility check](#)