

SiR-Hoechst for Super-Resolution Microscopy: An In-depth Technical Guide

Author: BenchChem Technical Support Team. **Date:** April 2026

Compound of Interest

Compound Name: *SiR-Hoechst*

Cat. No.: *B12379234*

[Get Quote](#)

For Researchers, Scientists, and Drug Development Professionals

The advent of super-resolution microscopy has revolutionized our ability to visualize cellular structures with unprecedented detail, breaking the diffraction limit of light microscopy. A key element in harnessing the full potential of these advanced imaging techniques is the development of specific and photostable fluorescent probes. **SiR-Hoechst**, a far-red, cell-permeable DNA stain, has emerged as a powerful tool for live-cell super-resolution imaging, offering distinct advantages over traditional nuclear stains. This technical guide provides a comprehensive overview of the key features of **SiR-Hoechst**, detailed experimental protocols, and its applications in super-resolution microscopy.

Core Features and Advantages of SiR-Hoechst

SiR-Hoechst is a conjugate of the silicon-rhodamine (SiR) fluorophore and the DNA minor groove binder Hoechst. This unique combination endows the probe with a set of highly desirable characteristics for high-resolution imaging of the nucleus in living cells.

Key Advantages:

- **Far-Red Excitation and Emission:** **SiR-Hoechst** is excited by far-red light (around 650 nm) and emits in the far-red spectrum (around 670 nm).[1][2] This spectral profile minimizes phototoxicity and cellular autofluorescence, which are common issues with UV or blue-light excitable dyes like traditional Hoechst stains.[1][3]
- **Minimal Toxicity:** Compared to other DNA stains, **SiR-Hoechst** exhibits significantly lower cytotoxicity, allowing for long-term live-cell imaging without perturbing cellular processes such as mitosis.[1][4] However, some studies suggest that at higher concentrations and with prolonged light exposure, **SiR-Hoechst** can induce DNA damage and cell cycle arrest, highlighting the importance of using the lowest effective concentration.[4][5]
- **Fluorogenic Nature:** **SiR-Hoechst** is fluorogenic, meaning its fluorescence intensity increases dramatically (approximately 50-fold) upon binding to DNA.[1][6] This property results in a high signal-to-noise ratio and eliminates the need for wash-out steps, simplifying experimental workflows.[1]
- **High Specificity for DNA:** The Hoechst moiety directs the probe to the minor groove of DNA, ensuring specific labeling of the nucleus.[6]
- **Compatibility with Super-Resolution Techniques:** **SiR-Hoechst** is particularly well-suited for Stimulated Emission Depletion (STED) microscopy.[1] Its photophysical properties allow for efficient depletion and the acquisition of images with a resolution well below the diffraction limit. While less common, its potential for use in Single-Molecule Localization Microscopy (SMLM) techniques like STORM and PALM is also being explored.[7][8]

Quantitative Data

For ease of comparison, the key quantitative properties of **SiR-Hoechst** are summarized in the table below.

Property	Value	Reference
Excitation Maximum (λ_{ex})	652 nm	[1]
Emission Maximum (λ_{em})	672 nm	[1]
Molar Extinction Coefficient (ϵ)	$1.0 \times 10^5 \text{ M}^{-1}\text{cm}^{-1}$	[9]
Quantum Yield (Φ) - DNA-bound	0.17	[6]
Quantum Yield (Φ) - Unbound	Low (not specified)	[10]
Binding Affinity (Kd) for DNA	8.4 μM	[1]
Fluorescence Enhancement upon DNA binding	~50-fold	[1][6]

Mechanism of Action: DNA Binding and Fluorogenicity

The functionality of **SiR-Hoechst** is based on two key molecular events: its specific binding to DNA and the resulting conformational change that triggers its fluorescence. In its unbound state, the SiR fluorophore exists predominantly in a non-fluorescent, closed spirolactone form. Upon the Hoechst component binding to the minor groove of the DNA double helix, a conformational change is induced in the SiR moiety. This shifts the equilibrium towards the open, fluorescent zwitterionic form, leading to a significant increase in fluorescence emission.

Mechanism of SiR-Hoechst Activation

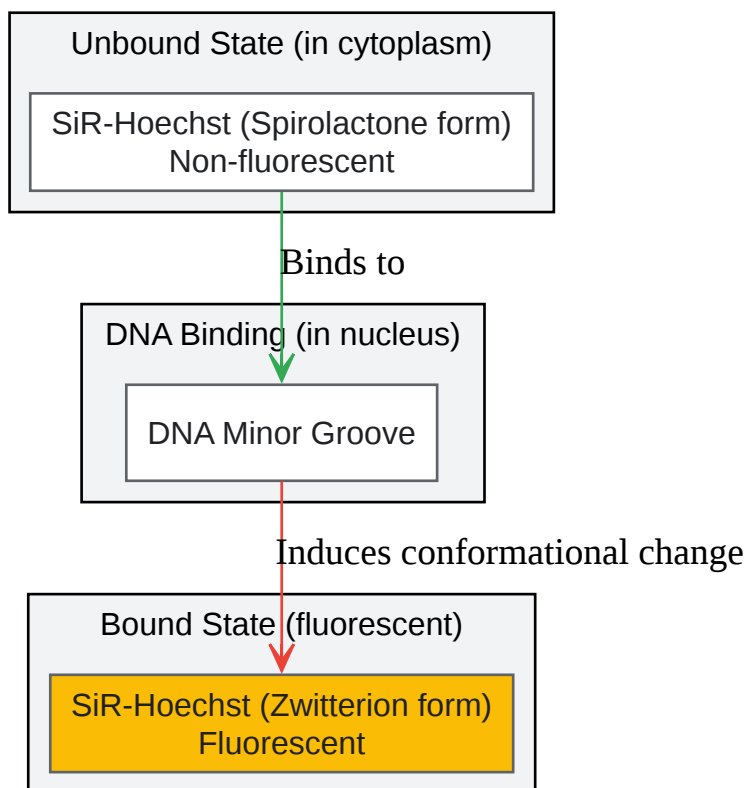

[Click to download full resolution via product page](#)

SiR-Hoechst DNA binding and fluorescence activation.

Experimental Protocols for Super-Resolution Microscopy

Live-Cell Staining with SiR-Hoechst (General Protocol)

This protocol provides a general guideline for staining live cells with **SiR-Hoechst**. Optimal concentrations and incubation times should be determined empirically for each cell type and experimental setup.

- Cell Culture: Culture cells on glass-bottom dishes or coverslips suitable for high-resolution microscopy.

- **Staining Solution Preparation:** Prepare a stock solution of **SiR-Hoechst** (typically 1 mM in DMSO). Dilute the stock solution in pre-warmed cell culture medium to the desired final concentration (typically ranging from 100 nM to 1 μ M).^[4] For cell lines with high efflux pump activity, co-incubation with an efflux pump inhibitor like verapamil (1-10 μ M) can improve staining efficiency.^{[1][5]}
- **Staining:** Replace the culture medium with the **SiR-Hoechst** staining solution.
- **Incubation:** Incubate the cells at 37°C in a humidified atmosphere with 5% CO₂ for 30 minutes to 2 hours.^{[2][11]}
- **Imaging:** The cells can be imaged directly in the staining solution without washing. For long-term imaging, it is recommended to replace the staining solution with fresh culture medium to minimize potential long-term toxicity.

Stimulated Emission Depletion (STED) Microscopy Protocol

SiR-Hoechst is an excellent probe for STED microscopy, enabling the visualization of chromatin structure with sub-diffraction resolution.

- **Cell Preparation and Staining:** Prepare and stain live cells with **SiR-Hoechst** as described in the general protocol. A concentration of 1-4 μ M for 2 hours has been shown to be effective for STED imaging.^{[2][11]}
- **Microscope Setup:**
 - **Excitation Laser:** Use a laser line around 640-650 nm for excitation.^[1]
 - **STED Laser:** A STED laser with a wavelength of 775 nm is commonly used for efficient depletion of **SiR-Hoechst** fluorescence.^[1]
 - **Detection:** Use a bandpass filter appropriate for the emission of **SiR-Hoechst** (e.g., 660-700 nm).
- **Image Acquisition:**

- Acquire a confocal overview image to locate the region of interest.
- Switch to STED mode and optimize the STED laser power to achieve the desired resolution while minimizing photobleaching.
- Adjust acquisition parameters such as pixel size, scan speed, and averaging to obtain high-quality images. A pixel size of 20-30 nm is typically used for STED imaging of chromatin.
- Data Analysis: The acquired STED images can be further processed and analyzed using appropriate software to quantify features of chromatin organization.

STED Microscopy Workflow with SiR-Hoechst

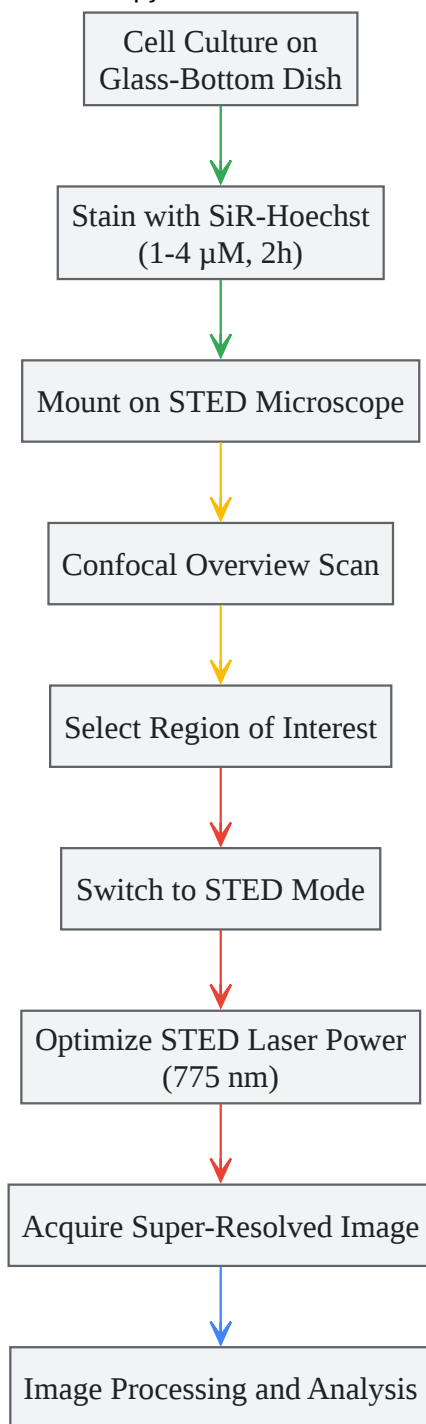

[Click to download full resolution via product page](#)

A typical workflow for STED imaging using **SiR-Hoechst**.

Application in Tracking Dynamic DNA Processes: Mitosis

SiR-Hoechst's suitability for live-cell imaging makes it an ideal tool for studying dynamic processes involving DNA, such as mitosis. The following diagram illustrates how **SiR-Hoechst** can be used to track the different stages of cell division.

Tracking Mitosis with SiR-Hoechst

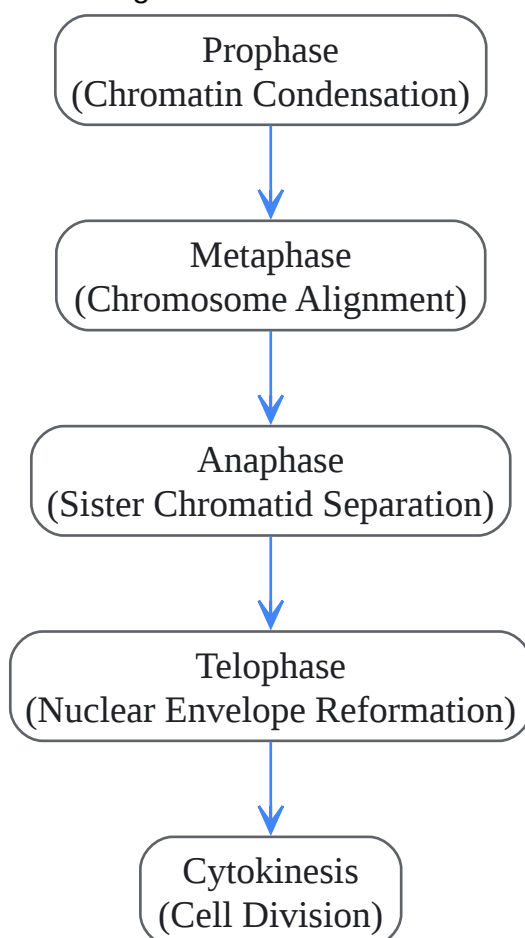

[Click to download full resolution via product page](#)

Visualizing mitotic stages with **SiR-Hoechst**.

Considerations for PALM and STORM

While **SiR-Hoechst** is primarily used for STED microscopy, its potential for Single-Molecule Localization Microscopy (SMLM) techniques like Photoactivated Localization Microscopy (PALM) and Stochastic Optical Reconstruction Microscopy (STORM) has been explored. These techniques rely on the stochastic photoswitching or "blinking" of individual fluorophores.

Standard SiR dyes do not inherently exhibit the robust blinking behavior required for SMLM. However, derivatives of SiR, such as HMSiR (hydroxymethyl silicon rhodamine), have been developed to exhibit spontaneous blinking, making them suitable for SMLM without the need for specific imaging buffers.[7][12] While a direct conjugate of a blinking SiR derivative with Hoechst for DNA-specific SMLM has been demonstrated, it is not as widely adopted as its use in STED.[12] For researchers interested in SMLM of DNA, alternative probes specifically designed for blinking might be more suitable.[8]

Conclusion

SiR-Hoechst has established itself as a valuable fluorescent probe for super-resolution microscopy, particularly for live-cell STED imaging of chromatin. Its far-red spectral properties, minimal toxicity, and fluorogenic nature offer significant advantages over traditional DNA stains. By following optimized protocols and understanding the probe's characteristics, researchers can leverage **SiR-Hoechst** to gain deeper insights into the intricate organization and dynamics of the genome at the nanoscale. As the field of super-resolution microscopy continues to evolve, the development of novel probes based on the SiR scaffold holds great promise for pushing the boundaries of biological imaging even further.

Need Custom Synthesis?

BenchChem offers custom synthesis for rare earth carbides and specific isotopic labeling.

Email: info@benchchem.com or [Request Quote Online](#).

References

- [1. SiR–Hoechst is a far-red DNA stain for live-cell nanoscopy - PMC \[pmc.ncbi.nlm.nih.gov\]](#)
- [2. researchgate.net \[researchgate.net\]](#)
- [3. SiR-Hoechst is a far-red DNA stain for live-cell nanoscopy - PubMed \[pubmed.ncbi.nlm.nih.gov\]](#)

- 4. SiR-DNA/SiR–Hoechst-induced chromosome entanglement generates severe anaphase bridges and DNA damage - PMC [[pmc.ncbi.nlm.nih.gov](https://pubmed.ncbi.nlm.nih.gov/)]
- 5. The live cell DNA stain SiR-Hoechst induces DNA damage responses and impairs cell cycle progression - PMC [[pmc.ncbi.nlm.nih.gov](https://pubmed.ncbi.nlm.nih.gov/)]
- 6. [mdpi.com](https://www.mdpi.com/) [[mdpi.com](https://www.mdpi.com/)]
- 7. [researchgate.net](https://www.researchgate.net/) [[researchgate.net](https://www.researchgate.net/)]
- 8. [researchgate.net](https://www.researchgate.net/) [[researchgate.net](https://www.researchgate.net/)]
- 9. SiR-DNA kit - Live cell DNA stain - spirochrome [[spirochrome.com](https://www.spirochrome.com/)]
- 10. [benchchem.com](https://www.benchchem.com/) [[benchchem.com](https://www.benchchem.com/)]
- 11. [researchgate.net](https://www.researchgate.net/) [[researchgate.net](https://www.researchgate.net/)]
- 12. A series of spontaneously blinking dyes for super-resolution microscopy - PMC [[pmc.ncbi.nlm.nih.gov](https://pubmed.ncbi.nlm.nih.gov/)]
- To cite this document: BenchChem. [SiR-Hoechst for Super-Resolution Microscopy: An In-depth Technical Guide]. BenchChem, [2026]. [Online PDF]. Available at: [<https://www.benchchem.com/product/b12379234/docs#sir-hoechst-for-super-resolution-microscopy-an-in-depth-technical-guide>]

Disclaimer & Data Validity:

The information provided in this document is for Research Use Only (RUO) and is strictly not intended for diagnostic or therapeutic procedures. While BenchChem strives to provide accurate protocols, we make no warranties, express or implied, regarding the fitness of this product for every specific experimental setup.

Technical Support: The protocols provided are for reference purposes. Unsure if this reagent suits your experiment?

Need Industrial/Bulk Grade? [Request Custom Synthesis Quote](#)

BenchChem

Our mission is to be the trusted global source of essential and advanced chemicals, empowering scientists and researchers to drive progress in science and industry.

Contact

Address: 3281 E Guasti Rd

Ontario, CA 91761, United States

Phone: (601) 213-4426

Email: info@benchchem.com

[Contact our Ph.D. Support Team for a compatibility check](#)