

Application Note: High-Throughput Screening for Novel Wee1 Inhibitors

Author: BenchChem Technical Support Team. **Date:** April 2026

Compound of Interest

Compound Name: Wee1-IN-6

Cat. No.: B12379157

[Get Quote](#)

Audience: Researchers, scientists, and drug development professionals.

Introduction Wee1 kinase is a critical regulator of the G2/M cell cycle checkpoint, preventing entry into mitosis in the presence of DNA damage to allow for repair.[1][2][3] It primarily functions by catalyzing the inhibitory phosphorylation of Cyclin-Dependent Kinase 1 (CDK1) at the Tyr15 residue.[4][5] Many cancer cells have defects in the G1 checkpoint (e.g., p53 mutations) and therefore rely heavily on the G2/M checkpoint for survival, making Wee1 an attractive therapeutic target.[3][5] Inhibition of Wee1 abrogates the G2/M checkpoint, forcing cancer cells with damaged DNA to enter mitosis prematurely, leading to mitotic catastrophe and cell death.[2][6] This application note provides an overview of high-throughput screening (HTS) strategies and detailed protocols for identifying and characterizing novel Wee1 inhibitors.

Wee1 Signaling Pathway

The Wee1 kinase is a central node in the DNA damage response pathway. Upon DNA damage, upstream kinases like ATM and ATR activate checkpoint kinases CHK1 and CHK2, which in turn phosphorylate and activate Wee1. Activated Wee1 then phosphorylates CDK1, holding the cell in the G2 phase. Wee1 inhibitors block this process, leading to unchecked CDK1 activity and premature mitotic entry.

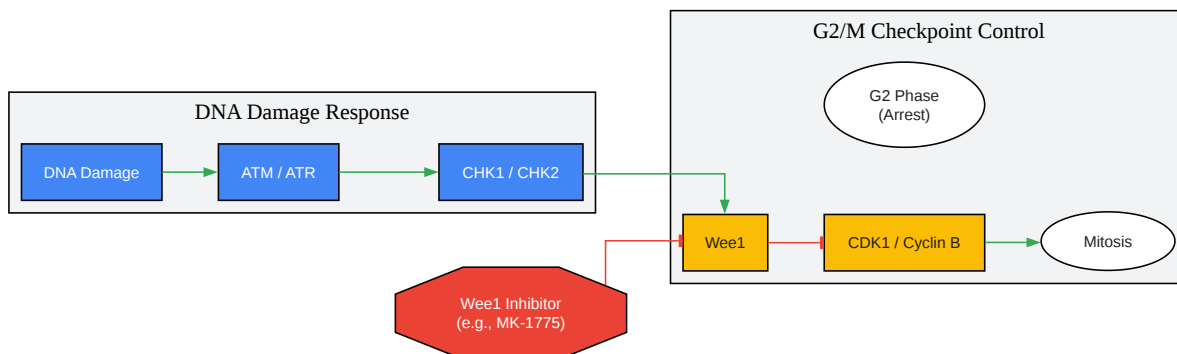

[Click to download full resolution via product page](#)

Caption: The Wee1 signaling pathway in G2/M checkpoint regulation.

High-Throughput Screening (HTS) Workflow

A typical HTS campaign for discovering novel Wee1 inhibitors follows a multi-stage process, beginning with a large-scale primary screen to identify initial hits, followed by a series of more detailed secondary and confirmatory assays to validate and characterize these compounds.

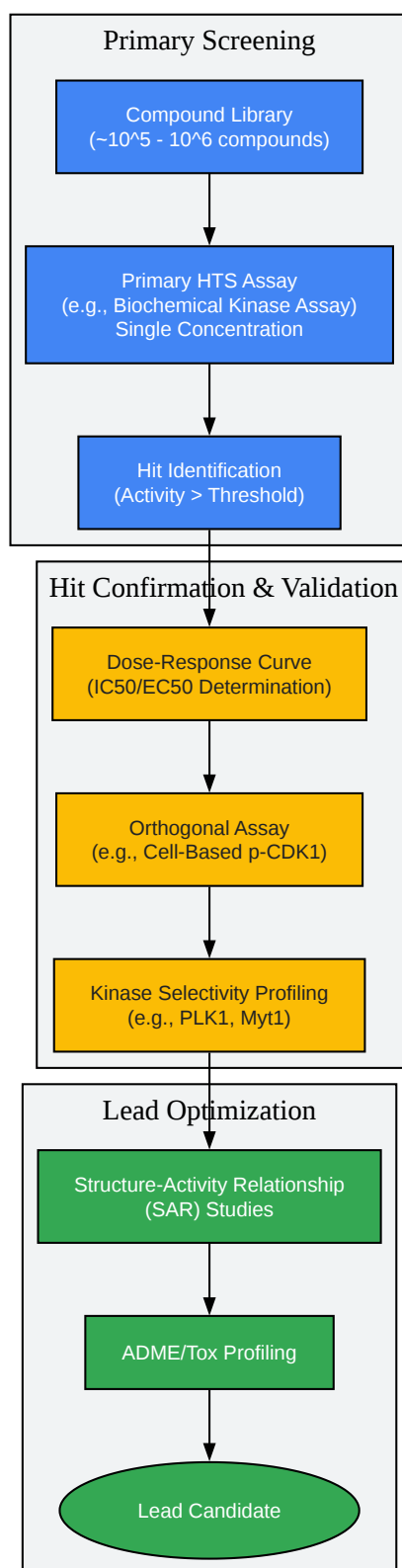

[Click to download full resolution via product page](#)

Caption: A generalized workflow for Wee1 inhibitor discovery.

Experimental Protocols and Data

Primary Screening: Biochemical Kinase Assays

Biochemical assays directly measure the enzymatic activity of purified Wee1 kinase and are ideal for primary HTS due to their robustness and simplicity. Luminescence-based assays that quantify ATP consumption, such as ADP-Glo™ or Kinase-Glo®, are commonly used.[1][7]

Protocol: Luminescence-Based Wee1 Kinase Activity Assay (96-well format)

This protocol is adapted from commercially available kits like the Chemi-Verse™ Wee1 Kinase Assay Kit.[7][8]

Materials:

- Recombinant Human Wee1 enzyme[1]
- Wee1 substrate (e.g., a generic peptide or its physiological substrate CDK1)[9]
- 5x Kinase Assay Buffer[1]
- ATP solution[1]
- Test compounds dissolved in DMSO
- ADP-Glo™ or Kinase-Glo® Reagent (Promega)
- White, opaque 96-well assay plates[1]
- Microplate reader capable of measuring luminescence

Procedure:

- Prepare 1x Kinase Buffer: Dilute the 5x Kinase Assay Buffer to 1x with deionized water.
- Prepare Reagent Master Mix: For each 100 reactions, prepare a master mix containing:
 - 480 µl 5x Kinase Assay Buffer

- 120 μ l 500 μ M ATP
- 1800 μ l Deionized Water
- Dispense Reagents: Add the following to the wells of a 96-well plate:
 - Test Wells: 2.5 μ l of test compound + 21.5 μ l of Master Mix.
 - Positive Control ("No Enzyme"): 2.5 μ l of DMSO + 24 μ l of 1x Kinase Buffer.
 - Negative Control ("Enzyme Activity"): 2.5 μ l of DMSO + 21.5 μ l of Master Mix.
- Initiate Reaction: Add 2.5 μ l of diluted Wee1 enzyme to the "Test Wells" and "Negative Control" wells. The final volume in all wells should be 26.5 μ l.
- Incubation: Gently mix the plate and incubate at 30°C for 45 minutes.
- ATP Detection:
 - Add 25 μ l of ADP-Glo™ Reagent to each well.
 - Incubate at room temperature for 40 minutes.
 - Add 50 μ l of Kinase Detection Reagent to each well.
 - Incubate at room temperature for another 30 minutes.
- Data Acquisition: Measure the luminescence using a microplate reader.
- Data Analysis: Calculate the percent inhibition for each test compound relative to the positive and negative controls. Plot the results to determine the IC50 value for active compounds.

Table 1: Biochemical Activity of Known Wee1 Inhibitors

Compound	Assay Type	Target	IC50 (nM)	Reference
MK-1775 (Adavosertib)	Enzymatic Assay	Wee1	5.2	[4]
Compound 4	Kinase Activity Assay	Wee1	1.069	[10][11]
Compound 5	Kinase Activity Assay	Wee1	3.77	[10][11]
PD0407824	HTS Program	Wee1	97	[12]
ZN-c3	Enzymatic Assay	Wee1	3.8	[6]

Secondary Screening: Cell-Based Assays

Cell-based assays are crucial for confirming the activity of hits from primary screens in a more physiologically relevant context. These assays can measure direct target engagement or downstream functional consequences of Wee1 inhibition.

A. Cell-Based Wee1 Degradation/Stabilization Assay

This assay measures the ability of compounds to stabilize a Wee1-luciferase fusion protein, providing a direct readout of target engagement within the cell.[13][14] An ultra-high-throughput screen (uHTS) using this method has been successfully implemented.[13][14][15]

Protocol: Wee1-Luciferase Reporter Assay (1536-well format)

This protocol is based on a published uHTS campaign for Wee1 stabilizers.[13][14]

Materials:

- HeLa cells
- Expression vector for a kinase-inactive Wee1 fused to luciferase (e.g., K328M-Wee1-Luc) [14]
- Transfection reagent

- Cryopreservation medium
- 1536-well assay plates
- Luciferase assay reagent (e.g., Bright-Glo™)
- Automated liquid handling system

Procedure:

- Cell Preparation:
 - Transfect HeLa cells in bulk with the Wee1-luciferase expression vector.
 - After expression, harvest and cryopreserve the cells in aliquots suitable for HTS.
- Assay Plate Preparation:
 - On the day of the screen, thaw the cryopreserved transfected cells and resuspend them at a concentration of 800,000 cells/mL.[14]
 - Using an automated dispenser, add 5 μ L of the cell suspension (4,000 cells) to each well of a 1536-well plate.[14]
- Compound Addition:
 - Add test compounds (typically 20-30 nL) to the assay plates to achieve a final desired concentration (e.g., 5 μ M).[14] Include DMSO-only wells as a negative control.
- Incubation: Incubate the plates for a defined period (e.g., 6-8 hours) at 37°C in a humidified incubator.
- Lysis and Signal Detection:
 - Add 3 μ L of luciferase assay reagent to each well.
 - Incubate for 5-10 minutes at room temperature to ensure complete cell lysis and signal stabilization.

- Data Acquisition: Measure the luminescence signal using a plate reader compatible with 1536-well format.
- Counterscreening: To eliminate non-selective or cytotoxic compounds, run parallel screens using a counterscreen construct (e.g., Cyclin B-luciferase) and a parental cell line viability assay.[\[13\]](#)[\[14\]](#)

B. Downstream Target Modulation Assay (p-CDK1)

This assay confirms the mechanism of action by measuring the phosphorylation of Wee1's primary substrate, CDK1, at Tyr15. Inhibition of Wee1 leads to a decrease in p-CDK1 (Tyr15) levels.

Protocol: HTRF® Total Wee1 Detection Assay

This protocol outline is based on commercially available kits that use Homogeneous Time-Resolved Fluorescence (HTRF).[\[16\]](#)

Materials:

- Cancer cell line (e.g., WiDr, A549)[\[4\]](#)[\[11\]](#)
- Cell culture medium and supplements
- Test compounds
- Lysis buffer
- HTRF Total Wee1 detection reagents (donor and acceptor-labeled antibodies)[\[16\]](#)
- Low-volume 384-well assay plates
- HTRF-compatible plate reader

Procedure:

- Cell Culture and Treatment:

- Seed cells in a 96-well culture plate and allow them to adhere overnight.
- Optional: Induce DNA damage with an agent like gemcitabine (100 nmol/L) for 24 hours to arrest cells in G2.[4]
- Treat cells with a dilution series of the test compound for a specified time (e.g., 8 hours).[4]
- Cell Lysis: Lyse the cells directly in the wells according to the kit manufacturer's instructions.
- Assay:
 - Transfer 16 μ L of cell lysate to a 384-well detection plate.
 - Add 4 μ L of the HTRF antibody mix to each well.
 - Seal the plate and incubate at room temperature for the time specified by the manufacturer (e.g., 4 hours or overnight).
- Data Acquisition: Read the plate on an HTRF-compatible reader, measuring emission at two wavelengths (e.g., 665 nm and 620 nm).
- Data Analysis: Calculate the HTRF ratio and plot the dose-response curve to determine the EC50 value.

Table 2: Cell-Based Activity of Known Wee1 Inhibitors

Compound	Assay Type	Cell Line	EC50 (nM)	Reference
MK-1775 (Adavosertib)	p-CDC2Y15 Inhibition (ELISA)	WiDr	85	[4]
MK-1775 (Adavosertib)	pHH3 Induction (Mitotic Entry)	WiDr	81	[4]
Compound 4	Anti-proliferation	A549	5171	[11]
Compound 4	Anti-proliferation	PC9	875	[11]
Compound 4	Anti-proliferation	HuH-7	147	[11]

Confirmatory Assays

Hits validated in secondary assays should be further characterized to understand their effects on cell fate.

- **Cell Cycle Analysis:** Flow cytometry is used to quantify the abrogation of the G2/M checkpoint. Wee1 inhibition in DNA-damaged cells causes a decrease in the G2/M population and an increase in the sub-G1 population (indicative of apoptosis) and the appearance of cells in mitosis (stained with markers like phospho-histone H3).[4][17][18]
- **DNA Damage Assays:** The consequence of forcing cells with damaged DNA into mitosis is an increase in markers of DNA double-strand breaks, such as γ H2AX.[17][18] This can be measured by flow cytometry or high-content imaging.
- **Colony Formation Assays:** These long-term assays assess the ability of a compound to reduce the clonogenic survival of cancer cells, providing a robust measure of its anti-proliferative effects.[18]

Need Custom Synthesis?

BenchChem offers custom synthesis for rare earth carbides and specific isotopic labeling.

Email: info@benchchem.com or [Request Quote Online](#).

References

1. bpsbioscience.com [bpsbioscience.com]
2. [Frontiers | WEE1 Inhibition in Combination With Targeted Agents and Standard Chemotherapy in Preclinical Models of Pancreatic Ductal Adenocarcinoma](https://www.frontiersin.org) [frontiersin.org]
3. [Frontiers | Recent Advances of WEE1 Inhibitors and Statins in Cancers With p53 Mutations](https://www.frontiersin.org) [frontiersin.org]
4. aacrjournals.org [aacrjournals.org]
5. [Structural Basis of Wee Kinases Functionality and Inactivation by Diverse Small Molecule Inhibitors - PMC](https://pubmed.ncbi.nlm.nih.gov) [pmc.ncbi.nlm.nih.gov]
6. [Selective Wee1 Inhibitors Led to Antitumor Activity In Vitro and Correlated with Myelosuppression - PMC](https://pubmed.ncbi.nlm.nih.gov) [pmc.ncbi.nlm.nih.gov]

- [7. bpsbioscience.com \[bpsbioscience.com\]](https://bpsbioscience.com)
- [8. biocompare.com \[biocompare.com\]](https://biocompare.com)
- [9. aacrjournals.org \[aacrjournals.org\]](https://aacrjournals.org)
- [10. researchgate.net \[researchgate.net\]](https://researchgate.net)
- [11. Discovery of potential WEE1 inhibitors via hybrid virtual screening - PMC \[pmc.ncbi.nlm.nih.gov\]](#)
- [12. pubs.acs.org \[pubs.acs.org\]](https://pubs.acs.org)
- [13. researchgate.net \[researchgate.net\]](https://researchgate.net)
- [14. An Ultra-High Throughput Cell-Based Screen for Wee1 Degradation Inhibitors - PMC \[pmc.ncbi.nlm.nih.gov\]](#)
- [15. An ultra-high throughput cell-based screen for wee1 degradation inhibitors - PubMed \[pubmed.ncbi.nlm.nih.gov\]](#)
- [16. HTRF Human and Mouse Total Wee1 Detection Kit, 500 Assay Points | Revvity \[revvity.com\]](#)
- [17. aacrjournals.org \[aacrjournals.org\]](https://aacrjournals.org)
- [18. Functional genetic screen identifies increased sensitivity to WEE1 inhibition in cells with defects in Fanconi Anaemia and HR pathways - PMC \[pmc.ncbi.nlm.nih.gov\]](#)
- To cite this document: BenchChem. [Application Note: High-Throughput Screening for Novel Wee1 Inhibitors]. BenchChem, [2026]. [Online PDF]. Available at: [\[https://www.benchchem.com/product/b12379157/docs#application-note-high-throughput-screening-for-novel-wee1-inhibitors\]](https://www.benchchem.com/product/b12379157/docs#application-note-high-throughput-screening-for-novel-wee1-inhibitors)

Disclaimer & Data Validity:

The information provided in this document is for Research Use Only (RUO) and is strictly not intended for diagnostic or therapeutic procedures. While BenchChem strives to provide accurate protocols, we make no warranties, express or implied, regarding the fitness of this product for every specific experimental setup.

Technical Support: The protocols provided are for reference purposes. Unsure if this reagent suits your experiment?

Need Industrial/Bulk Grade? [Request Custom Synthesis Quote](#)

BenchChem

Our mission is to be the trusted global source of essential and advanced chemicals, empowering scientists and researchers to drive progress in science and industry.

Contact

Address: 3281 E Guasti Rd

Ontario, CA 91761, United States

Phone: (601) 213-4426

Email: info@benchchem.com

[Contact our Ph.D. Support Team for a compatibility check](#)