

An In-depth Technical Guide to NO₂A-Butyne-bis(t-Butyl ester)

Author: BenchChem Technical Support Team. **Date:** April 2026

Compound of Interest

Compound Name: NO₂A-Butyne-bis(t-Butyl ester)

Cat. No.: B12379555

[Get Quote](#)

CAS Number: 2125661-91-6

Chemical Name: 1,4,7-Triazacyclononane-1,4-bis(t-butylacetate)-7-(3-butynylacetamide)

This technical guide provides a comprehensive overview of **NO₂A-Butyne-bis(t-Butyl ester)**, a bifunctional chelator developed for researchers, scientists, and drug development professionals. This document outlines its chemical properties, potential applications in radiopharmaceutical development, and generalized experimental protocols based on analogous compounds.

Core Concepts and Physicochemical Properties

NO₂A-Butyne-bis(t-Butyl ester) is a macrocyclic bifunctional chelator (BFC) derived from 1,4,7-triazacyclononane (NOTA).^{[1][2]} Its structure is engineered to serve two primary functions: a robust chelating core for radiometals and a reactive butyne group for conjugation to biomolecules.^{[3][4]} The NOTA framework is well-established for its ability to form highly stable complexes with various radiometals, particularly those used in Positron Emission Tomography (PET) imaging, such as Gallium-68 (⁶⁸Ga) and Copper-64 (⁶⁴Cu).^{[5][6]} The tert-butyl ester groups on the acetate arms serve as protecting groups, which can be removed post-conjugation or during radiolabeling under acidic conditions.

The butyne functional group allows for covalent attachment to targeting vectors like peptides, antibodies, or small molecules via "click chemistry," specifically the copper(I)-catalyzed azide-alkyne cycloaddition (CuAAC) or the strain-promoted azide-alkyne cycloaddition (SPAAC). This versatility makes it a valuable tool in the development of targeted radiopharmaceuticals for imaging and therapy.[7] Its primary application lies in tumor pre-targeting strategies, where a modified antibody is first administered, followed by a small, rapidly clearing radiolabeled chelator complex that binds to the antibody at the tumor site.[2][8]

Table 1: Physicochemical Properties of **NO2A-Butyne-bis(t-Butyl ester)**

Property	Value	Source
CAS Number	2125661-91-6	[3]
Molecular Formula	C ₂₄ H ₄₂ N ₄ O ₅	[3]
Molecular Weight	466.6 g/mol	[3]
Chemical Name	1,4,7-Triazacyclononane-1,4-bis(t-butylacetate)-7-(3-butynylacetamide)	[3]
Purity	Typically >90-95%	[9]
Appearance	Solid (details vary by supplier)	[9]
Storage Conditions	-20°C, protected from light and moisture	[9]

Synthesis and Characterization

While a specific, peer-reviewed synthesis for **NO2A-Butyne-bis(t-Butyl ester)** is not readily available, a plausible synthetic route can be inferred from established methods for creating similar NOTA derivatives. The synthesis would likely begin with the di-alkylation of 1,4,7-triazacyclononane (TACN) with tert-butyl bromoacetate to form the di-substituted intermediate, 1,4,7-Triazacyclononane-1,4-bis(t-butyl acetate).[10] The remaining secondary amine on the macrocycle would then be acylated using an activated form of butynoic acid (e.g., butynoyl chloride or an NHS ester) to yield the final product.

General Characterization Methods: Characterization of the final product would typically involve:

- Nuclear Magnetic Resonance (NMR) Spectroscopy: ^1H and ^{13}C NMR to confirm the chemical structure and the presence of the butyne and tert-butyl ester groups.
- Mass Spectrometry (MS): To verify the molecular weight and elemental composition.
- High-Performance Liquid Chromatography (HPLC): To assess the purity of the compound.

Experimental Protocols

The following protocols are generalized methodologies based on the use of similar NOTA-based bifunctional chelators in the scientific literature. Researchers should optimize these protocols for their specific applications.

Conjugation to Azide-Modified Biomolecules via CuAAC

The butyne group of **NO2A-Butyne-bis(t-Butyl ester)** is designed for conjugation to molecules containing an azide group through copper(I)-catalyzed azide-alkyne cycloaddition (CuAAC), a form of "click chemistry."

Materials:

- **NO2A-Butyne-bis(t-Butyl ester)**
- Azide-functionalized peptide or other biomolecule
- Copper(II) sulfate (CuSO_4)
- Sodium ascorbate
- Solvent (e.g., DMSO, DMF, or a mixture with aqueous buffer)

Protocol:

- Dissolve the azide-modified biomolecule and a slight molar excess of **NO2A-Butyne-bis(t-Butyl ester)** in the chosen solvent system.
- In a separate vial, prepare fresh solutions of CuSO_4 and sodium ascorbate in water.

- Add the sodium ascorbate solution to the reaction mixture, followed by the CuSO₄ solution. The sodium ascorbate reduces Cu(II) to the catalytic Cu(I) species in situ.
- Allow the reaction to proceed at room temperature for 1-4 hours. The reaction progress can be monitored by HPLC or LC-MS.
- Upon completion, the conjugated product can be purified using techniques appropriate for the biomolecule, such as reverse-phase HPLC or size-exclusion chromatography, to remove unreacted starting materials and the copper catalyst.

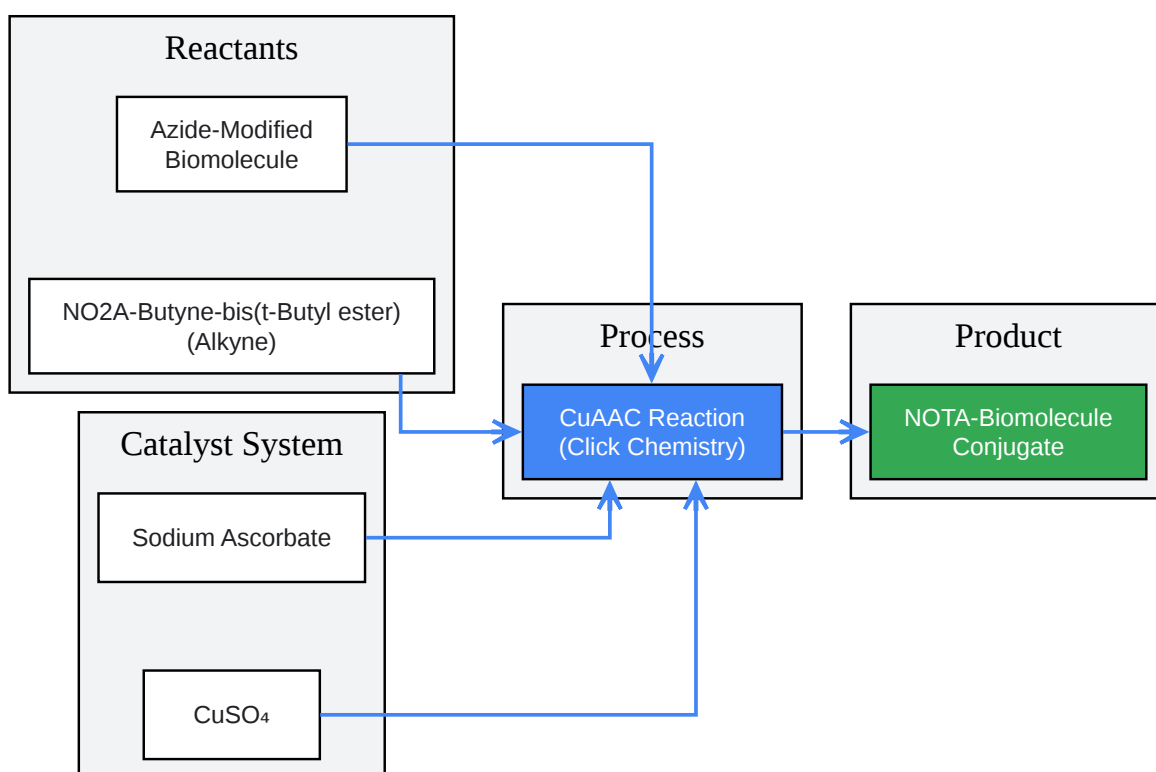

[Click to download full resolution via product page](#)

Fig 1: CuAAC Conjugation Workflow

Radiolabeling with Copper-64

NOTA chelators are known for their efficient complexation of ⁶⁴Cu at room temperature, which is advantageous for heat-sensitive biomolecules.[6][11]

Materials:

- NOTA-biomolecule conjugate
- $^{64}\text{CuCl}_2$ in dilute HCl
- Ammonium acetate or sodium acetate buffer (typically 0.1 M, pH 5.5-6.5)
- Metal-free water and reaction vials

Protocol:

- In a metal-free microcentrifuge tube, dissolve the NOTA-biomolecule conjugate in the acetate buffer. The concentration will depend on the desired specific activity.
- Add the $^{64}\text{CuCl}_2$ solution to the conjugate solution. The volume should be minimized to maintain a high concentration of reactants.
- Gently mix and incubate the reaction mixture at room temperature for 15-30 minutes. For some conjugates, gentle heating (e.g., 37-40°C) may improve efficiency, but room temperature is often sufficient.[\[11\]](#)
- The efficiency of the radiolabeling reaction should be determined by radio-TLC or radio-HPLC. A typical system for radio-TLC would be a C18 plate with a mobile phase of 50 mM EDTA to separate chelated ^{64}Cu from free ^{64}Cu .
- If necessary, the radiolabeled conjugate can be purified from unchelated ^{64}Cu using a C18 Sep-Pak cartridge or other suitable chromatography method.

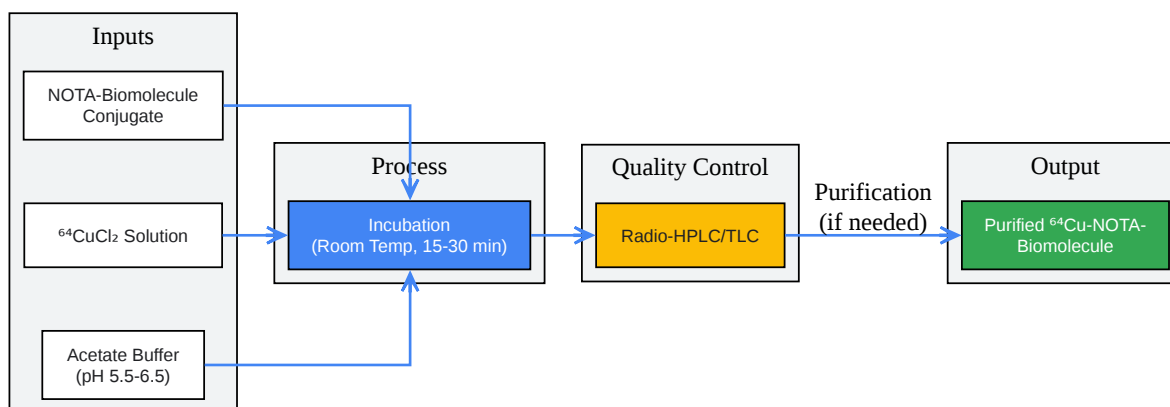

[Click to download full resolution via product page](#)

Fig 2: ^{64}Cu Radiolabeling Workflow

Application in Pre-targeted PET Imaging

NO2A-Butyne-bis(t-Butyl ester) is described as a tool for tumor pre-targeting.[12] This advanced imaging strategy aims to improve the tumor-to-background signal ratio and reduce the radiation dose to the patient compared to traditional radioimmunotherapy.[8]

The strategy typically involves a bioorthogonal "click" reaction that occurs in vivo.

- **Step 1: Antibody Administration:** A tumor-targeting antibody, modified with a bioorthogonal reactive group (e.g., a trans-cyclooctene, TCO), is administered to the patient. This antibody is allowed to accumulate at the tumor site and clear from the bloodstream over a period of 24-72 hours.[2]
- **Step 2: Radiotracer Administration:** The small molecule, in this case, a ^{64}Cu -labeled tetrazine-NOTA construct, is administered. (Note: The butyne group on the title compound would be reacted with an azide-tetrazine linker prior to this step). This radiolabeled molecule is small enough to clear rapidly from the body through the renal system.[8]

- Step 3: In Vivo Ligation: The circulating radiolabeled tetrazine rapidly reacts with the TCO-modified antibody accumulated at the tumor via an inverse-electron-demand Diels-Alder cycloaddition. This "clicks" the radioactivity onto the tumor-bound antibody, allowing for high-contrast PET imaging.[2][8]

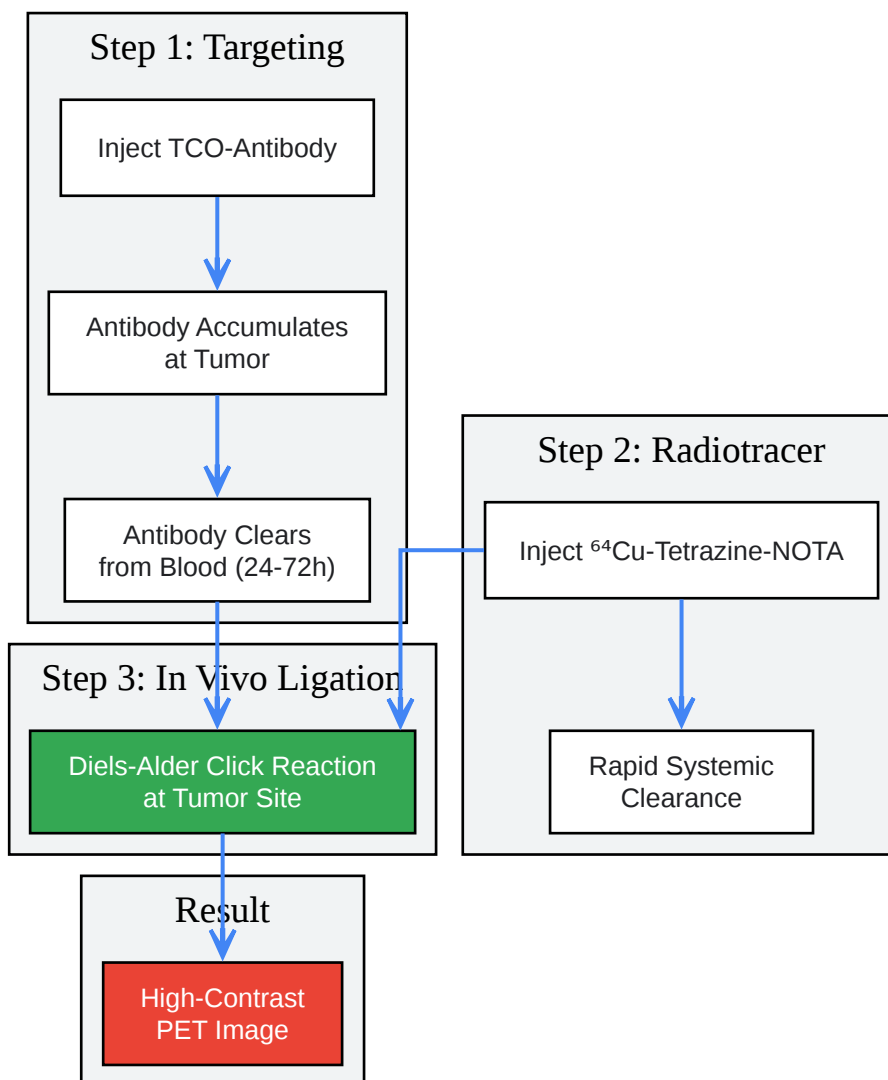

[Click to download full resolution via product page](#)

Fig 3: Pre-targeted PET Imaging Strategy

Conclusion

NO₂A-Butyne-bis(t-Butyl ester) is a promising bifunctional chelator for the development of next-generation radiopharmaceuticals. Its combination of a stable NOTA core for radiometal

complexation and a versatile butyne handle for bioorthogonal conjugation makes it a valuable component in modular imaging and therapy platforms. While specific literature on this exact compound is sparse, the well-documented chemistry of NOTA derivatives and butyne linkers provides a strong foundation for its application in advanced strategies like pre-targeted PET imaging. Further research and publication on its specific performance characteristics will be crucial for its adoption in clinical and preclinical research.

Need Custom Synthesis?

BenchChem offers custom synthesis for rare earth carbides and specific isotopic labeling.

Email: info@benchchem.com or [Request Quote Online](#).

References

- 1. [mdpi.com](https://www.mdpi.com) [[mdpi.com](https://www.mdpi.com)]
- 2. A Pretargeted PET Imaging Strategy Based on Bioorthogonal Diels–Alder Click Chemistry - PMC [[pmc.ncbi.nlm.nih.gov](https://pubmed.ncbi.nlm.nih.gov/)]
- 3. [macrocyclics.com](https://www.macrocyclics.com) [[macrocyclics.com](https://www.macrocyclics.com)]
- 4. NO₂A-Butyne-bis (t-Butyl ester) | AxisPharm [[axispharm.com](https://www.axispharm.com)]
- 5. Maleimido-Functionalized NOTA Derivatives as Bifunctional Chelators for Site-Specific Radiolabeling - PMC [[pmc.ncbi.nlm.nih.gov](https://pubmed.ncbi.nlm.nih.gov/)]
- 6. Copper-64 radiolabeling and biological evaluation of bifunctional chelators for radiopharmaceutical development Evaluation of ⁶⁴Cu-bifunctional chelators - PMC [[pmc.ncbi.nlm.nih.gov](https://pubmed.ncbi.nlm.nih.gov/)]
- 7. investigacion.unirioja.es [investigacion.unirioja.es]
- 8. Optimization of a Pretargeted Strategy for the PET Imaging of Colorectal Carcinoma via the Modulation of Radioligand Pharmacokinetics - PMC [[pmc.ncbi.nlm.nih.gov](https://pubmed.ncbi.nlm.nih.gov/)]
- 9. NO₂A-Butyne-bis (t-Butyl ester) - Ruixibiotech [[ruixibiotech.com](https://www.ruixibiotech.com)]
- 10. A Practical Route for the Preparation of 1,4,7-Triazacyclononyl Diacetates with a Hydroxypyridinonate Pendant Arm - PMC [[pmc.ncbi.nlm.nih.gov](https://pubmed.ncbi.nlm.nih.gov/)]
- 11. Radiolabeling Strategies of Nanobodies for Imaging Applications - PMC [[pmc.ncbi.nlm.nih.gov](https://pubmed.ncbi.nlm.nih.gov/)]
- 12. [gentaur.com](https://www.gentaur.com) [[gentaur.com](https://www.gentaur.com)]

- To cite this document: BenchChem. [An In-depth Technical Guide to NO₂A-Butyne-bis(t-Butyl ester)]. BenchChem, [2026]. [Online PDF]. Available at: [<https://www.benchchem.com/product/b12379555/docs#an-in-depth-technical-guide-to-no2a-butyne-bis-t-butyl-ester>]

Disclaimer & Data Validity:

The information provided in this document is for Research Use Only (RUO) and is strictly not intended for diagnostic or therapeutic procedures. While BenchChem strives to provide accurate protocols, we make no warranties, express or implied, regarding the fitness of this product for every specific experimental setup.

Technical Support: The protocols provided are for reference purposes. Unsure if this reagent suits your experiment?

Need Industrial/Bulk Grade? [Request Custom Synthesis Quote](#)

BenchChem

Our mission is to be the trusted global source of essential and advanced chemicals, empowering scientists and researchers to drive progress in science and industry.

Contact

Address: 3281 E Guasti Rd
Ontario, CA 91761, United States
Phone: (601) 213-4426
Email: info@benchchem.com

[Contact our Ph.D. Support Team for a compatibility check](#)