

# Technical Support Center: Optimizing PCSK9-IN-22 Dosage and Administration

**Author:** BenchChem Technical Support Team. **Date:** April 2026

## Compound of Interest

Compound Name: PCSK9-IN-22

Cat. No.: B12377129

[Get Quote](#)

This technical support center provides troubleshooting guides and frequently asked questions (FAQs) for researchers, scientists, and drug development professionals working with **PCSK9-IN-22**, a small molecule inhibitor of the PCSK9-LDLR interaction. The following information is designed to address common issues encountered during in vitro experiments.

## Frequently Asked Questions (FAQs)

Q1: What is the mechanism of action for **PCSK9-IN-22**?

A1: **PCSK9-IN-22** is an orally active, small molecule inhibitor that disrupts the protein-protein interaction between Proprotein Convertase Subtilisin/Kexin type 9 (PCSK9) and the Low-Density Lipoprotein Receptor (LDLR).[1][2] Normally, PCSK9 binds to the LDLR on the surface of hepatocytes, targeting the receptor for lysosomal degradation.[3] This reduction in LDLR density on the cell surface leads to decreased clearance of LDL cholesterol (LDL-C) from the bloodstream. By inhibiting the PCSK9-LDLR interaction, **PCSK9-IN-22** prevents the degradation of the LDLR, allowing it to be recycled back to the cell surface. This results in an increased number of LDLRs available to clear circulating LDL-C.[4][5]

Q2: What is the recommended starting concentration for in vitro experiments?

A2: For a novel small molecule inhibitor like **PCSK9-IN-22**, it is recommended to perform a dose-response experiment to determine the optimal concentration for your specific cell type and assay. A starting point could be a range of concentrations based on the IC50 values of similar published small molecule PCSK9 inhibitors. For example, some small molecule inhibitors show activity in the nanomolar to low micromolar range. A broad concentration range (e.g., 1 nM to 100  $\mu$ M) is advisable for initial characterization.

Q3: How should I prepare and store **PCSK9-IN-22** stock solutions?

A3: **PCSK9-IN-22** is typically provided as a solid. For in vitro use, it is often dissolved in a solvent like DMSO to create a high-concentration stock solution (e.g., 10 mM). It is crucial to use freshly opened, anhydrous DMSO, as hygroscopic DMSO can significantly impact the solubility of the compound. Stock solutions should be stored at -20°C or -80°C to maintain stability. When preparing working solutions, dilute the stock in your cell culture medium. Be mindful of the final DMSO concentration in your assay, as high concentrations can be toxic to cells. It is recommended to keep the final DMSO concentration below 0.5%.

Q4: What cell lines are suitable for testing **PCSK9-IN-22** activity?

A4: Human hepatic carcinoma cells, such as HepG2, are a commonly used and relevant cell line for studying LDL metabolism and the effects of PCSK9 inhibitors.[6] These cells express both PCSK9 and LDLR, making them an excellent model to study the effects of inhibitors on LDLR levels and LDL uptake.

Q5: What are the expected outcomes of a successful **PCSK9-IN-22** experiment?

A5: A successful experiment with an effective dose of **PCSK9-IN-22** should result in:

- An increase in the protein levels of the LDL receptor (LDLR) on the cell surface.
- An enhanced uptake of fluorescently labeled LDL (e.g., DiI-LDL) by the cells. These outcomes can be measured by Western blotting for LDLR and fluorescence microscopy or plate-based assays for LDL uptake.

## Troubleshooting Guides

Issue 1: No observable effect on LDLR levels or LDL uptake.

Possible Cause	Troubleshooting Steps
Inactive Compound	Verify the integrity of the compound. Ensure it has been stored correctly as per the manufacturer's instructions. If possible, test its activity in a well-established positive control assay.
Incorrect Concentration	Perform a dose-response experiment with a wider range of concentrations. The optimal concentration may be higher or lower than initially tested.
Solubility Issues	Ensure the compound is fully dissolved in the stock solution and does not precipitate when diluted in the culture medium. Prepare fresh dilutions for each experiment.
Cell Health/Passage Number	Use cells at a low passage number and ensure they are healthy and in the logarithmic growth phase. High passage numbers can lead to altered cellular responses.
Assay Timing	The effects of PCSK9 inhibition on LDLR levels and LDL uptake may take time to become apparent. Optimize the incubation time with the inhibitor (e.g., 12-24 hours) and the duration of the LDL uptake assay (e.g., 3-4 hours).[6]

Issue 2: High background or inconsistent results in the LDL uptake assay.

Possible Cause	Troubleshooting Steps
Non-specific binding of fluorescent LDL	Ensure adequate washing steps to remove unbound fluorescent LDL before imaging or plate reading.
Cell Seeding Density	Optimize the cell seeding density to achieve a consistent monolayer. Over-confluent or under-confluent cells can lead to variability.
Inconsistent Treatment	Ensure uniform application of the inhibitor and fluorescent LDL to all wells. Use a multichannel pipette for better consistency.
Microplate Selection	For fluorescence-based assays, use black-walled, clear-bottom plates to reduce background signal and well-to-well crosstalk.

### Issue 3: Observed cytotoxicity at effective concentrations.

Possible Cause	Troubleshooting Steps
Compound Toxicity	Perform a cell viability assay (e.g., MTT or trypan blue exclusion) in parallel with your functional assay to determine the cytotoxic threshold of PCSK9-IN-22. Use a concentration that is effective but non-toxic.
High Solvent Concentration	Ensure the final concentration of the solvent (e.g., DMSO) in the culture medium is below the toxic level for your cell line (typically <0.5%).
Off-target Effects	The observed toxicity may be due to the inhibitor interacting with other cellular targets. If possible, test a structurally different inhibitor of the same target to see if the toxicity is recapitulated.

## Data Presentation

Table 1: Example In Vitro Activity of a Small Molecule PCSK9 Inhibitor

Assay Type	Cell Line	Endpoint	Example IC50/EC50
PCSK9-LDLR Binding Assay	-	Inhibition of Protein-Protein Interaction	500 nM
Cellular LDL Uptake Assay	HepG2	Increased DiI-LDL Uptake	1 $\mu$ M
LDLR Protein Expression	HepG2	Increased LDLR levels (Western Blot)	1 $\mu$ M

Note: The values presented are hypothetical examples for a representative small molecule PCSK9 inhibitor and should be determined experimentally for **PCSK9-IN-22**.

## Experimental Protocols

### Protocol 1: Cellular LDL Uptake Assay in HepG2 Cells

This protocol describes how to measure the effect of **PCSK9-IN-22** on the uptake of fluorescently labeled LDL in HepG2 cells.

Materials:

- HepG2 cells
- Complete culture medium (e.g., DMEM with 10% FBS)
- **PCSK9-IN-22**
- DMSO (anhydrous)
- Fluorescently labeled LDL (e.g., DiI-LDL)
- Phosphate-Buffered Saline (PBS)

- 96-well black, clear-bottom microplate

#### Methodology:

- Cell Seeding: Seed HepG2 cells in a 96-well black, clear-bottom plate at a density of  $3 \times 10^4$  cells/well. Allow cells to adhere and grow for 48 hours.
- Compound Treatment: Prepare serial dilutions of **PCSK9-IN-22** in complete culture medium. Remove the old medium from the cells and add the medium containing the different concentrations of **PCSK9-IN-22**. Include a vehicle control (medium with the same final concentration of DMSO). Incubate for 20-24 hours.
- LDL Uptake: Prepare a working solution of Dil-LDL (e.g., 10-30  $\mu\text{g}/\text{mL}$ ) in serum-free medium. Remove the medium containing the inhibitor and add the Dil-LDL working solution. Incubate for 3-4 hours at 37°C in the dark.[6]
- Washing: Remove the Dil-LDL solution and wash the cells three times with PBS to remove any unbound Dil-LDL.
- Analysis: Add PBS to each well and measure the fluorescence using a microplate reader (e.g., excitation/emission  $\sim 540/570$  nm for Dil). Alternatively, visualize and quantify the uptake using a fluorescence microscope.

## Protocol 2: Western Blot for LDLR Expression

This protocol details the detection of changes in LDLR protein levels following treatment with **PCSK9-IN-22**.

#### Materials:

- HepG2 cells
- 6-well plates
- **PCSK9-IN-22**
- Lysis buffer (e.g., RIPA buffer with protease inhibitors)

- BCA protein assay kit
- SDS-PAGE gels and running buffer
- Transfer buffer and PVDF membrane
- Blocking buffer (e.g., 5% non-fat milk in TBST)
- Primary antibody against LDLR
- Primary antibody against a loading control (e.g., GAPDH or  $\beta$ -actin)
- HRP-conjugated secondary antibody
- Chemiluminescent substrate

#### Methodology:

- Cell Treatment: Seed HepG2 cells in 6-well plates and grow to ~80% confluency. Treat the cells with the desired concentrations of **PCSK9-IN-22** or vehicle control for 24 hours.
- Cell Lysis: Wash the cells with ice-cold PBS and lyse them with lysis buffer.
- Protein Quantification: Determine the protein concentration of each lysate using a BCA assay.
- SDS-PAGE and Transfer: Load equal amounts of protein from each sample onto an SDS-PAGE gel. Separate the proteins by electrophoresis and transfer them to a PVDF membrane.
- Blocking and Antibody Incubation: Block the membrane with blocking buffer for 1 hour at room temperature. Incubate the membrane with the primary anti-LDLR antibody overnight at 4°C.
- Secondary Antibody and Detection: Wash the membrane and incubate with the HRP-conjugated secondary antibody for 1 hour at room temperature. After further washing, apply the chemiluminescent substrate and visualize the protein bands using an imaging system.

- Analysis: Quantify the band intensities and normalize the LDLR signal to the loading control to determine the relative change in LDLR expression.

## Mandatory Visualizations

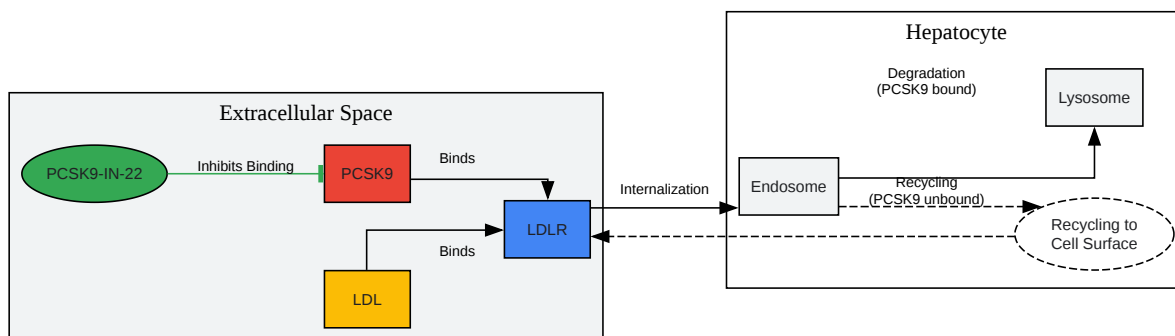

[Click to download full resolution via product page](#)

Caption: PCSK9 signaling pathway and the inhibitory action of **PCSK9-IN-22**.

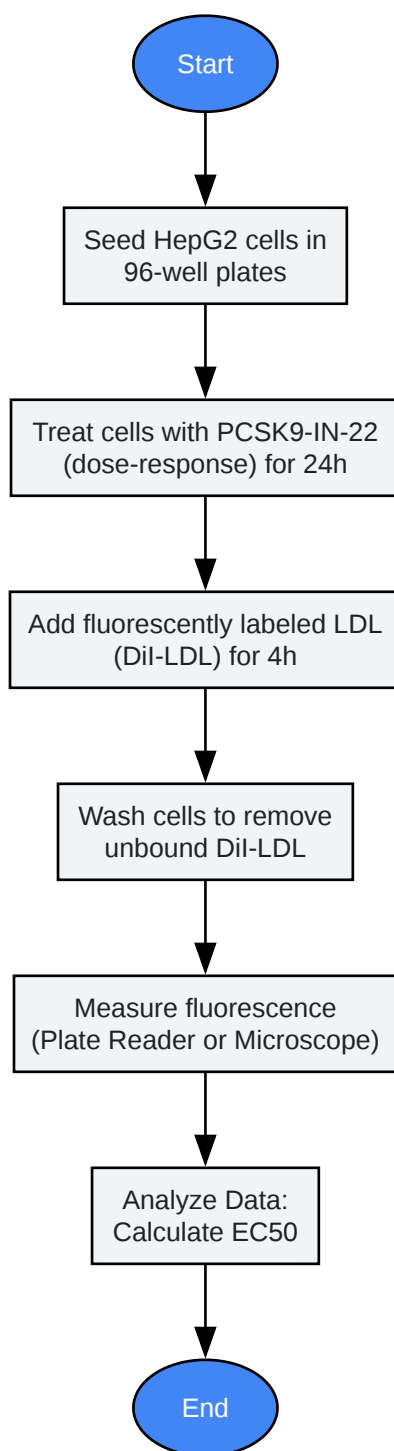

[Click to download full resolution via product page](#)

Caption: Experimental workflow for a cellular LDL uptake assay.

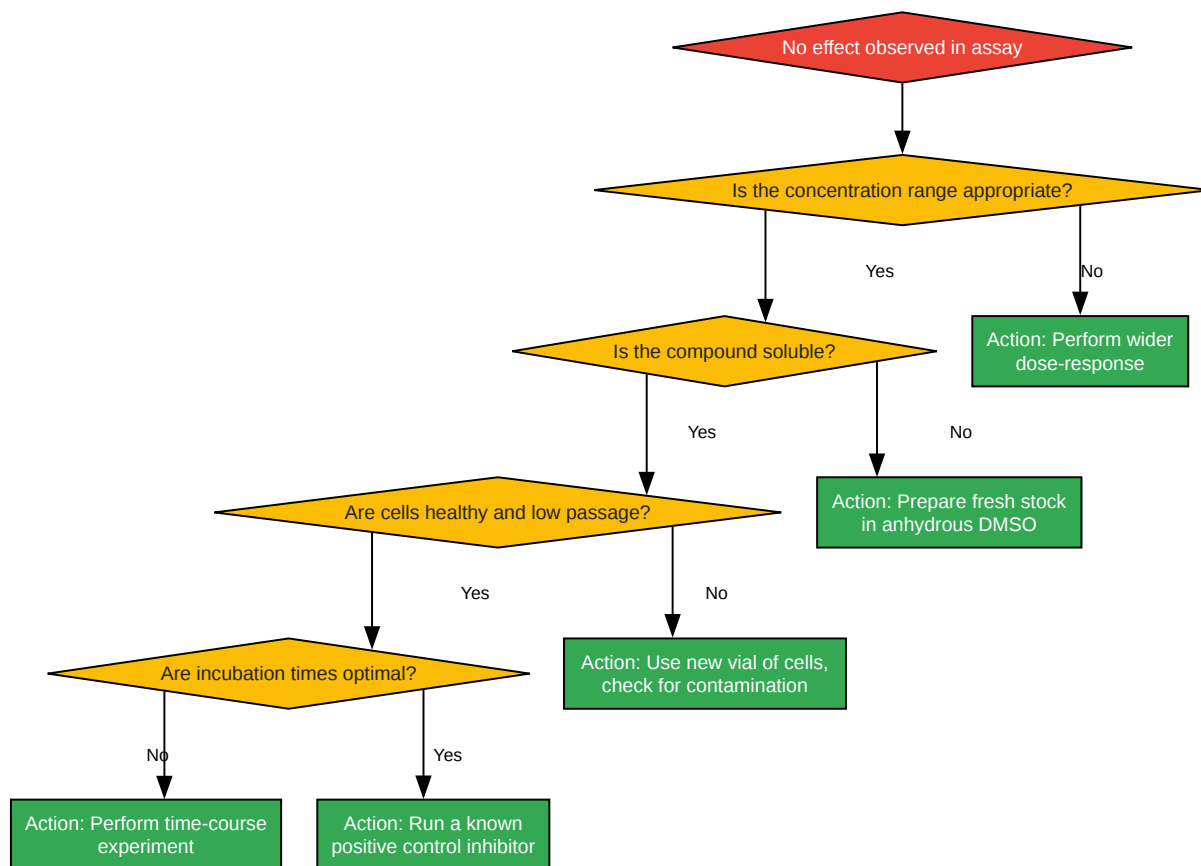

[Click to download full resolution via product page](#)

### Need Custom Synthesis?

BenchChem offers custom synthesis for rare earth carbides and specific isotopic labeling.

Email: [info@benchchem.com](mailto:info@benchchem.com) or [Request Quote Online](#).

## References

- 1. LDL Cholesterol Uptake Assay Using Live Cell Imaging Analysis with Cell Health Monitoring [jove.com]

- [2. Protein-Protein Interactions Support—Troubleshooting | Thermo Fisher Scientific - HK \[thermofisher.com\]](#)
- [3. Troubleshooting Cell-based Assays Ask the Experts to Avoid Common Pitfalls from Cell Seeding to Analysis \[worldwide.promega.com\]](#)
- [4. LDL Cholesterol Uptake Assay Using Live Cell Imaging Analysis with Cell Health Monitoring - PMC \[pmc.ncbi.nlm.nih.gov\]](#)
- [5. cdn.caymanchem.com \[cdn.caymanchem.com\]](#)
- [6. Gallic Acid Can Promote Low-Density Lipoprotein Uptake in HepG2 Cells via Increasing Low-Density Lipoprotein Receptor Accumulation - PMC \[pmc.ncbi.nlm.nih.gov\]](#)
- To cite this document: BenchChem. [Technical Support Center: Optimizing PCSK9-IN-22 Dosage and Administration]. BenchChem, [2026]. [Online PDF]. Available at: [\[https://www.benchchem.com/product/b12377129/docs#technical-support-center-optimizing-pcsk9-in-22-dosage-and-administration\]](https://www.benchchem.com/product/b12377129/docs#technical-support-center-optimizing-pcsk9-in-22-dosage-and-administration)

---

#### Disclaimer & Data Validity:

The information provided in this document is for Research Use Only (RUO) and is strictly not intended for diagnostic or therapeutic procedures. While BenchChem strives to provide accurate protocols, we make no warranties, express or implied, regarding the fitness of this product for every specific experimental setup.

**Technical Support:** The protocols provided are for reference purposes. Unsure if this reagent suits your experiment?

**Need Industrial/Bulk Grade?** [Request Custom Synthesis Quote](#)

## BenchChem

Our mission is to be the trusted global source of essential and advanced chemicals, empowering scientists and researchers to drive progress in science and industry.

#### Contact

Address: 3281 E Guasti Rd

Ontario, CA 91761, United States

Phone: (601) 213-4426

Email: [info@benchchem.com](mailto:info@benchchem.com)

Contact our Ph.D. Support Team for a compatibility check