

Technical Support Center: Fgfr3-IN-8

Author: BenchChem Technical Support Team. **Date:** April 2026

Compound of Interest

Compound Name: *Fgfr3-IN-8*

Cat. No.: *B12377132*

[Get Quote](#)

Welcome to the technical support center for **Fgfr3-IN-8**. This resource is designed to assist researchers, scientists, and drug development professionals in effectively utilizing **Fgfr3-IN-8** while minimizing potential degradation. Here you will find troubleshooting guides, frequently asked questions (FAQs), and detailed experimental protocols to ensure the integrity of your experiments.

Frequently Asked Questions (FAQs)

Q1: What is **Fgfr3-IN-8** and what is its mechanism of action?

A1: **Fgfr3-IN-8** is a selective inhibitor of Fibroblast Growth Factor Receptor 3 (FGFR3). FGFR3 is a receptor tyrosine kinase that, when activated by fibroblast growth factors (FGFs), triggers downstream signaling pathways involved in cell proliferation, differentiation, and migration. In certain cancers, such as bladder cancer, mutations or amplifications of the FGFR3 gene can lead to constitutive activation of these pathways, promoting tumor growth. **Fgfr3-IN-8** acts as an ATP-competitive inhibitor, binding to the kinase domain of FGFR3 and blocking its autophosphorylation and the subsequent activation of downstream signaling cascades like the MAPK and PI3K/Akt pathways.

Q2: What are the recommended storage and handling conditions for **Fgfr3-IN-8**?

A2: While specific storage conditions should always be confirmed by consulting the Certificate of Analysis provided by the supplier, general recommendations for small molecule inhibitors like **Fgfr3-IN-8** often include storage at low temperatures in a dry, dark environment to prevent degradation. For short-term storage, refrigeration (2-8 °C) is common, while long-term storage is typically recommended at -20°C or -80°C. Stock solutions, often prepared in solvents like DMSO, should also be stored at low temperatures in aliquots to avoid repeated freeze-thaw cycles.

Q3: How can I assess the stability of my **Fgfr3-IN-8** solution?

A3: The stability of your **Fgfr3-IN-8** solution can be assessed using analytical techniques such as High-Performance Liquid Chromatography (HPLC) or Liquid Chromatography-Mass Spectrometry (LC-MS). These methods can separate the parent compound from any potential degradation products, allowing for quantification of the inhibitor's purity over time under different storage conditions. A detailed protocol for stability assessment is provided in the "Experimental Protocols" section.

Q4: What are the common causes of small molecule inhibitor degradation?

A4: Degradation of small molecule inhibitors can be influenced by several factors, including:

- Temperature: Elevated temperatures can accelerate chemical reactions leading to degradation.
- Light: Exposure to UV or even ambient light can cause photodegradation of sensitive compounds.
- pH: The stability of a compound can be pH-dependent, with acidic or basic conditions potentially causing hydrolysis or other reactions.
- Oxidation: Reaction with oxygen can lead to oxidative degradation.
- Solvent: The choice of solvent and its purity can impact compound stability. Water content in solvents like DMSO can be particularly problematic.
- Repeated Freeze-Thaw Cycles: Aliquoting stock solutions is recommended to avoid the physical stress of repeated temperature changes.

Troubleshooting Guide

This guide addresses common issues encountered during experiments with **Fgfr3-IN-8**, with a focus on preventing degradation.

Problem	Possible Cause	Recommended Solution
Inconsistent or lower than expected experimental results.	Fgfr3-IN-8 may have degraded due to improper storage or handling.	<ol style="list-style-type: none">1. Verify the storage conditions of your Fgfr3-IN-8 powder and stock solutions. Always refer to the supplier's Certificate of Analysis.2. Prepare fresh stock solutions from a new vial of the compound.3. Perform a stability check of your current stock solution using HPLC or LC-MS (see Experimental Protocols).
Precipitate observed in the stock solution upon thawing.	The solubility limit of Fgfr3-IN-8 in the chosen solvent may have been exceeded, or the compound may have precipitated out of solution during freezing.	<ol style="list-style-type: none">1. Gently warm the solution and vortex to redissolve the precipitate.2. If precipitation persists, consider preparing a fresh, less concentrated stock solution.3. Ensure the solvent is of high purity and anhydrous, as water can affect solubility and stability.
Loss of inhibitor activity over time in cell culture experiments.	Fgfr3-IN-8 may be unstable in the cell culture medium at 37°C. The compound may also be metabolized by the cells.	<ol style="list-style-type: none">1. Determine the half-life of Fgfr3-IN-8 in your specific cell culture medium by incubating the compound in the medium at 37°C and analyzing samples at different time points via HPLC or LC-MS.2. If the compound is found to be unstable, consider replenishing the medium with fresh inhibitor at regular intervals during long-term experiments.
Variability between different batches of Fgfr3-IN-8.	There may be differences in the purity or formulation of the	<ol style="list-style-type: none">1. Always purchase from a reputable supplier and request

compound between batches.

a Certificate of Analysis for each new batch. 2. Perform a quality control check on each new batch, for example, by determining the IC50 in a standard assay and comparing it to previous batches.

Data Presentation

Table 1: General Storage and Handling Recommendations for **Fgfr3-IN-8**

Form	Storage Condition	Handling Recommendations
Solid Powder	Store at -20°C or -80°C for long-term storage. Keep in a desiccator to protect from moisture. Protect from light.	Allow the vial to warm to room temperature before opening to prevent condensation. Weigh out the required amount quickly in a controlled environment.
Stock Solution (in DMSO)	Store at -20°C or -80°C in small, single-use aliquots to avoid freeze-thaw cycles. Protect from light.	Use high-purity, anhydrous DMSO to prepare stock solutions. Ensure the compound is fully dissolved before use.
Working Solution (in aqueous buffer/media)	Prepare fresh for each experiment. Avoid storing for extended periods.	The stability in aqueous solutions can be limited. If storage is necessary, perform a stability study to determine the acceptable storage duration and conditions.

Experimental Protocols

Protocol 1: Preparation of **Fgfr3-IN-8** Stock Solution

- Materials: **Fgfr3-IN-8** powder, anhydrous dimethyl sulfoxide (DMSO), sterile microcentrifuge tubes.
- Procedure: a. Allow the vial of **Fgfr3-IN-8** powder to equilibrate to room temperature before opening. b. Weigh the desired amount of **Fgfr3-IN-8** powder in a sterile microcentrifuge tube. c. Add the appropriate volume of anhydrous DMSO to achieve the desired stock concentration (e.g., 10 mM). d. Vortex the solution until the powder is completely dissolved. Gentle warming (e.g., in a 37°C water bath for a few minutes) may aid dissolution. e. Aliquot the stock solution into single-use, light-protected tubes. f. Store the aliquots at -20°C or -80°C.

Protocol 2: Assessment of **Fgfr3-IN-8** Stability by HPLC

- Objective: To determine the stability of **Fgfr3-IN-8** under specific conditions (e.g., in a particular solvent, at a certain temperature, or over a specific time).
- Materials: **Fgfr3-IN-8** solution to be tested, HPLC system with a suitable column (e.g., C18), mobile phase (e.g., a gradient of acetonitrile and water with a modifier like formic acid or trifluoroacetic acid), reference standard of **Fgfr3-IN-8**.
- Procedure: a. Timepoint 0: Immediately after preparing the **Fgfr3-IN-8** solution, dilute a sample to a suitable concentration for HPLC analysis and inject it into the HPLC system. This will serve as the baseline. b. Incubation: Store the remaining solution under the desired test conditions (e.g., in a 37°C incubator, on a lab bench exposed to light, or at 4°C). c. Subsequent Timepoints: At predetermined time intervals (e.g., 1, 2, 4, 8, 24 hours), take an aliquot of the stored solution, dilute it to the same concentration as the timepoint 0 sample, and inject it into the HPLC system. d. Data Analysis: i. For each timepoint, identify the peak corresponding to **Fgfr3-IN-8** based on the retention time of the reference standard. ii. Integrate the peak area of **Fgfr3-IN-8** at each timepoint. iii. Calculate the percentage of **Fgfr3-IN-8** remaining at each timepoint relative to the peak area at timepoint 0. iv. The appearance of new peaks may indicate the formation of degradation products.

Visualizations

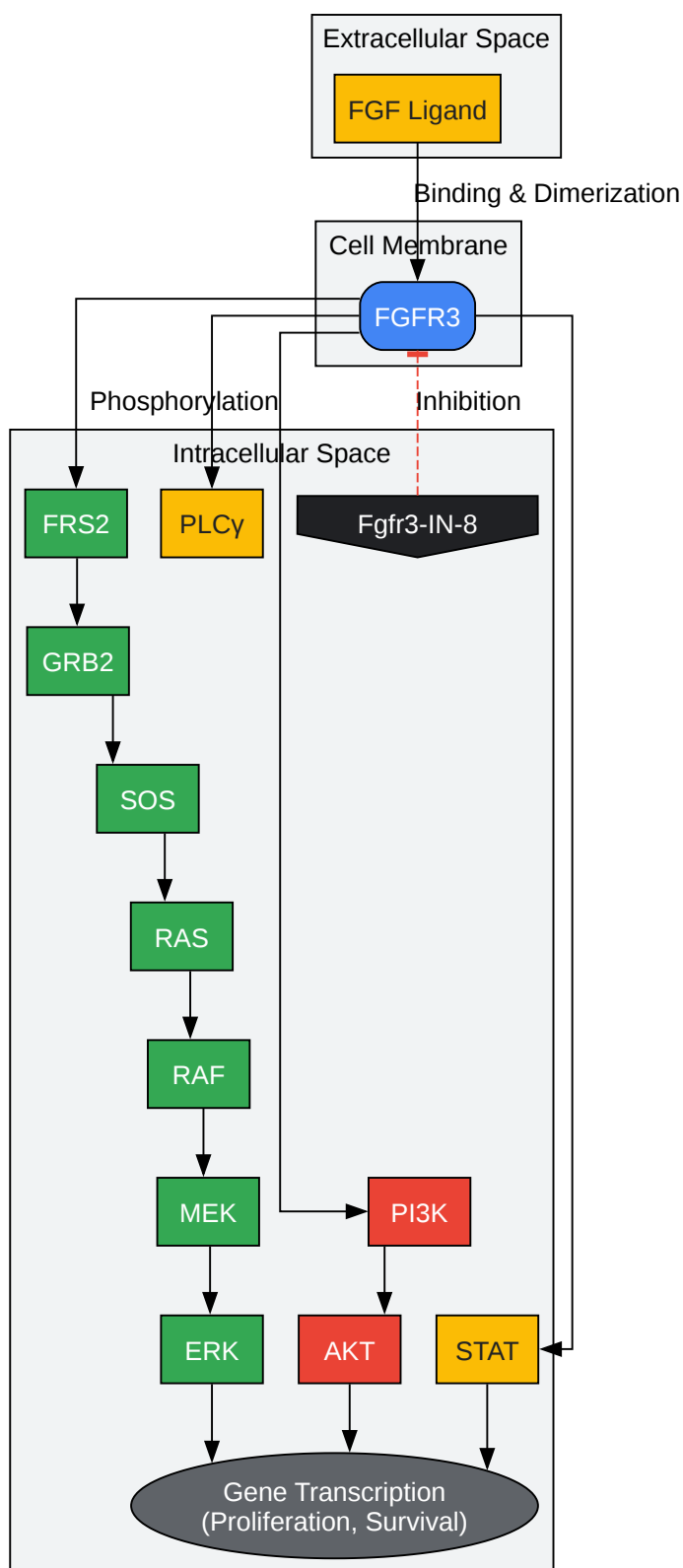

[Click to download full resolution via product page](#)

Caption: Simplified FGFR3 signaling pathway and the inhibitory action of **Fgfr3-IN-8**.

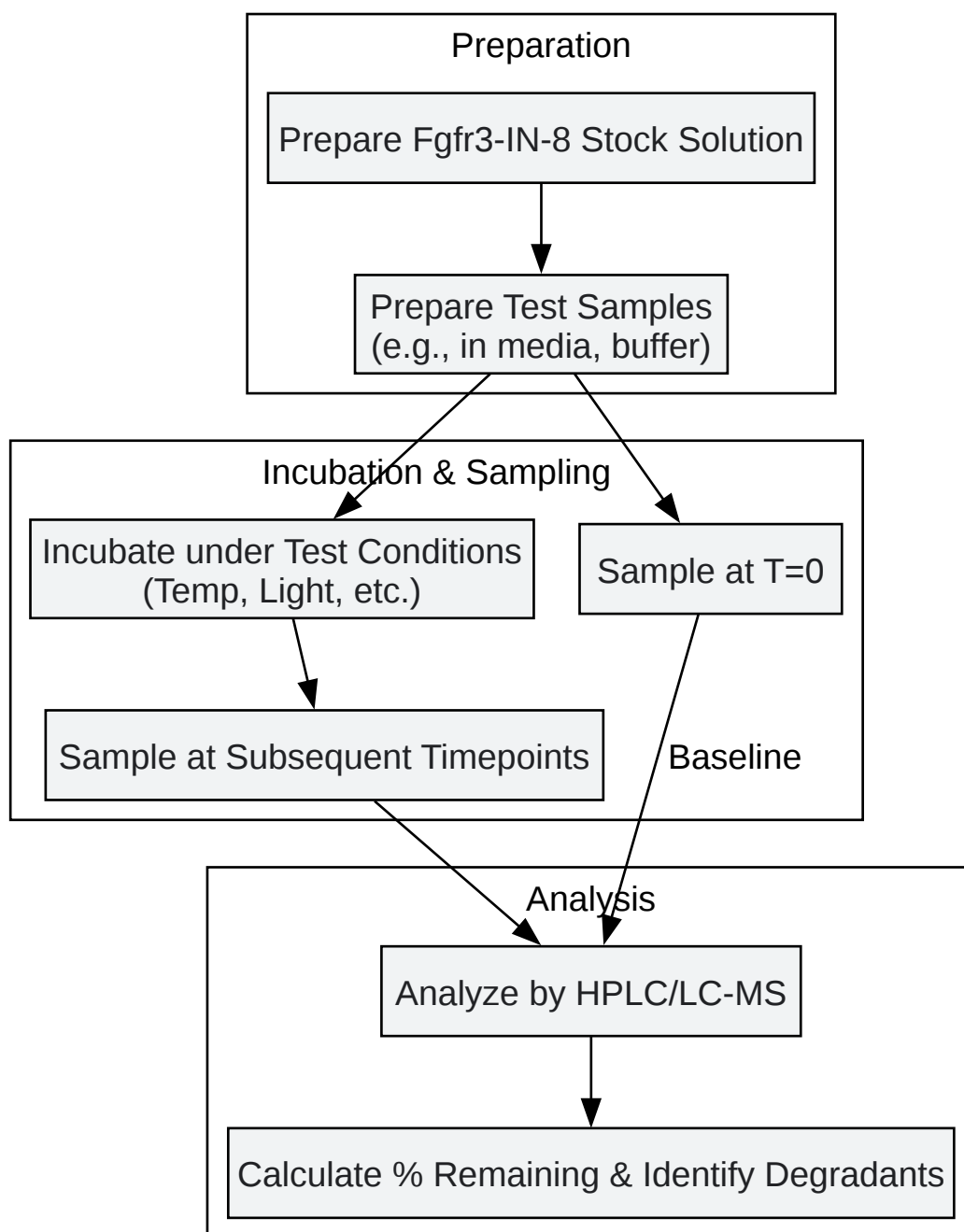

[Click to download full resolution via product page](#)

Caption: Experimental workflow for assessing the stability of **Fgfr3-IN-8**.

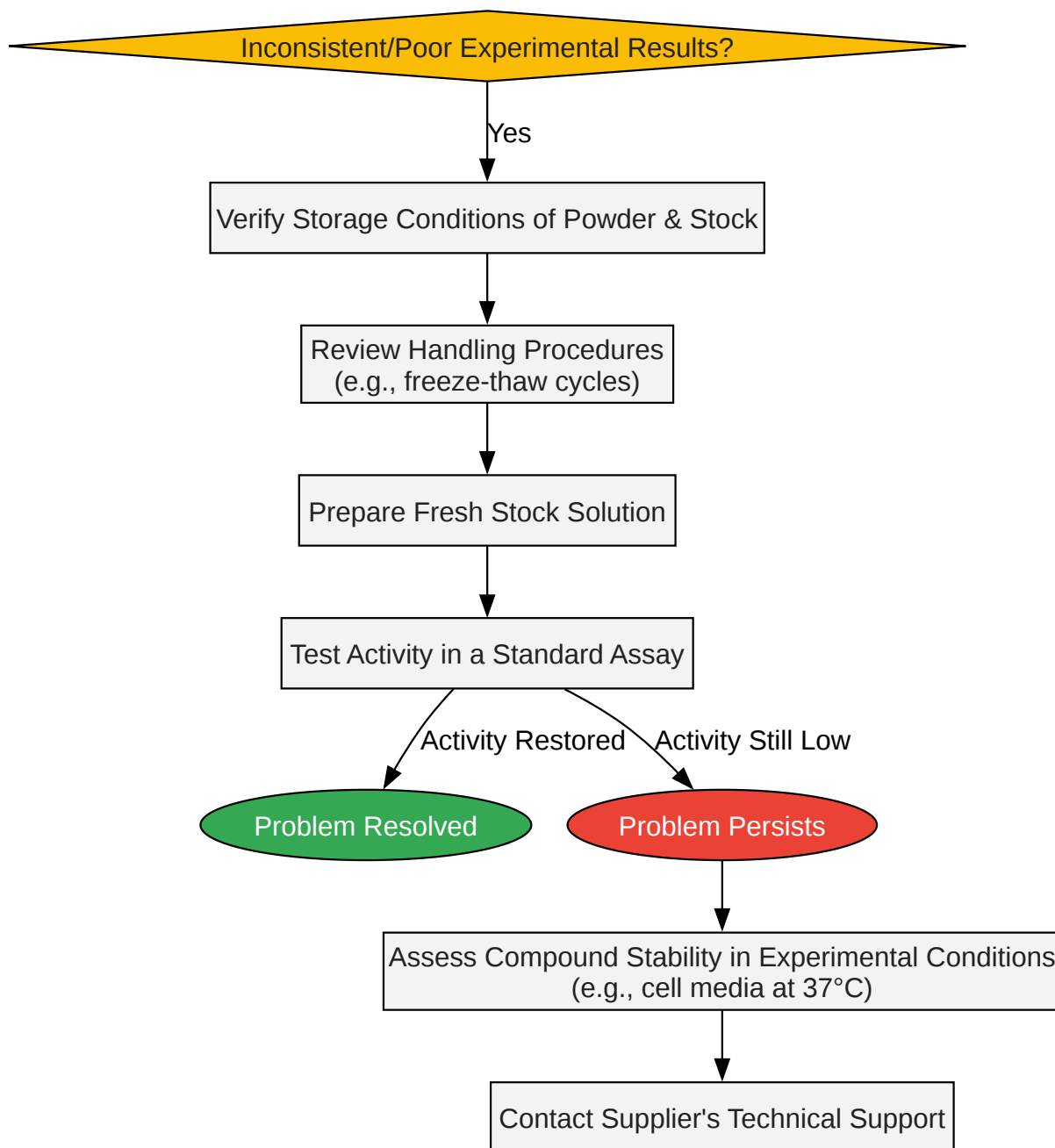

[Click to download full resolution via product page](#)

Caption: Troubleshooting logic for addressing issues with **Fgfr3-IN-8**.

- To cite this document: BenchChem. [Technical Support Center: Fgfr3-IN-8]. BenchChem, [2026]. [Online PDF]. Available at: [\[https://www.benchchem.com/product/b12377132/docs#technical-support-center-fgfr3-in-8\]](https://www.benchchem.com/product/b12377132/docs#technical-support-center-fgfr3-in-8)

Disclaimer & Data Validity:

The information provided in this document is for Research Use Only (RUO) and is strictly not intended for diagnostic or therapeutic procedures. While BenchChem strives to provide accurate protocols, we make no warranties, express or implied, regarding the fitness of this product for every specific experimental setup.

Technical Support: The protocols provided are for reference purposes. Unsure if this reagent suits your experiment?

Need Industrial/Bulk Grade? [Request Custom Synthesis Quote](#)

BenchChem

Our mission is to be the trusted global source of essential and advanced chemicals, empowering scientists and researchers to drive progress in science and industry.

Contact

Address: 3281 E Guasti Rd
Ontario, CA 91761, United States
Phone: (601) 213-4426
Email: info@benchchem.com

[Contact our Ph.D. Support Team for a compatibility check](#)