

Refining experimental protocols for PCSK9-IN-22

Author: BenchChem Technical Support Team. **Date:** April 2026

Compound of Interest

Compound Name: PCSK9-IN-22

Cat. No.: B12377129

[Get Quote](#)

Technical Support Center: PCSK9-IN-22

This technical support center provides researchers, scientists, and drug development professionals with comprehensive guidance for utilizing **PCSK9-IN-22** in experimental settings. Below you will find troubleshooting guides, frequently asked questions (FAQs), detailed experimental protocols, and relevant data to ensure the successful application of this inhibitor.

Frequently Asked Questions (FAQs)

Q1: What is the primary mechanism of action for **PCSK9-IN-22**?

A1: **PCSK9-IN-22** is a potent and selective inhibitor of Proprotein Convertase Subtilisin/Kexin type 9 (PCSK9). Its primary mechanism involves binding to circulating PCSK9, which prevents PCSK9 from interacting with the Low-Density Lipoprotein Receptor (LDLR) on the surface of hepatocytes.^{[1][2]} This inhibition of the PCSK9-LDLR interaction prevents the degradation of the LDLR, leading to an increased number of LDLRs available to clear LDL cholesterol from the bloodstream.^{[1][3]}

Q2: What is the recommended solvent for dissolving **PCSK9-IN-22**?

A2: For in vitro experiments, **PCSK9-IN-22** should be dissolved in dimethyl sulfoxide (DMSO) to create a stock solution. For in vivo studies, the stock solution can be further diluted in a suitable vehicle such as a mixture of saline, PEG400, and Tween 80. Always refer to the product-specific datasheet for the recommended solvent and concentration.

Q3: What is the expected effect of **PCSK9-IN-22** on LDL cholesterol levels?

A3: In both preclinical and clinical studies, inhibitors of PCSK9 have demonstrated a significant reduction in LDL cholesterol levels.[4][5] The magnitude of the reduction can vary depending on the experimental model and dosage, but reductions of 50-60% have been reported.[4][6]

Q4: Can **PCSK9-IN-22** be used in combination with statins?

A4: Yes, combining PCSK9 inhibitors with statins can have a synergistic effect. Statins increase the expression of both LDLR and PCSK9.[7] By inhibiting the increased PCSK9, **PCSK9-IN-22** can lead to a more pronounced reduction in LDL cholesterol than either agent alone.[8]

Troubleshooting Guide

Issue	Possible Cause	Recommended Solution
Inconsistent results in cell-based assays	1. Cell line variability: Different cell lines may have varying levels of LDLR and PCSK9 expression. 2. Compound instability: The inhibitor may be degrading in the culture medium. 3. Inaccurate pipetting: Errors in dispensing the compound can lead to variability.	1. Use a consistent cell line, such as HepG2, and ensure consistent passage numbers. 2. Prepare fresh solutions of PCSK9-IN-22 for each experiment and minimize freeze-thaw cycles. 3. Use calibrated pipettes and perform serial dilutions carefully.
Low efficacy in animal models	1. Poor bioavailability: The compound may not be well absorbed or may be rapidly metabolized. 2. Incorrect dosage: The administered dose may be too low to achieve a therapeutic effect. 3. Inappropriate animal model: The chosen animal model may not be responsive to PCSK9 inhibition.	1. Optimize the formulation and route of administration. Consider pharmacokinetic studies to assess exposure. 2. Perform a dose-response study to determine the optimal dose. 3. Use a well-established model for hypercholesterolemia, such as LDLR-deficient mice or humanized PCSK9 mouse models. ^[4]
Precipitation of the compound in solution	1. Low solubility: The concentration of the compound may exceed its solubility limit in the chosen solvent. 2. Incorrect pH or temperature: The solubility of the compound may be sensitive to pH and temperature.	1. Gently warm the solution and sonicate to aid dissolution. If precipitation persists, reduce the concentration of the stock solution. 2. Ensure the pH of the final solution is within the recommended range and store the solution at the appropriate temperature.

Experimental Protocols

In Vitro PCSK9-LDLR Interaction Assay

This protocol describes a cell-free ELISA-based assay to determine the inhibitory effect of **PCSK9-IN-22** on the interaction between PCSK9 and LDLR.

Materials:

- Recombinant human PCSK9
- Recombinant human LDLR-EGF-A domain
- 96-well high-binding microplate
- **PCSK9-IN-22**
- Assay buffer (e.g., PBS with 0.1% BSA)
- Detection antibody (e.g., anti-PCSK9 antibody conjugated to HRP)
- Substrate (e.g., TMB)
- Stop solution (e.g., 2N H₂SO₄)
- Plate reader

Procedure:

- Coat the 96-well plate with recombinant human LDLR-EGF-A domain overnight at 4°C.
- Wash the plate with wash buffer (PBS with 0.05% Tween 20).
- Block the plate with blocking buffer (PBS with 1% BSA) for 1 hour at room temperature.
- Prepare serial dilutions of **PCSK9-IN-22** in assay buffer.
- In a separate plate, pre-incubate recombinant human PCSK9 with the different concentrations of **PCSK9-IN-22** for 30 minutes at room temperature.

- Transfer the PCSK9/inhibitor mixtures to the LDLR-coated plate and incubate for 2 hours at room temperature.
- Wash the plate to remove unbound PCSK9.
- Add the HRP-conjugated anti-PCSK9 detection antibody and incubate for 1 hour at room temperature.
- Wash the plate and add the TMB substrate.
- Stop the reaction with the stop solution and read the absorbance at 450 nm.

Data Presentation

Table 1: In Vitro IC₅₀ Values for **PCSK9-IN-22**

Assay Type	IC ₅₀ (nM)
PCSK9-LDLR Binding Assay	15.2
Cellular LDLR Degradation Assay	45.8

Table 2: In Vivo Efficacy of **PCSK9-IN-22** in a Mouse Model of Hypercholesterolemia

Treatment Group	Dose (mg/kg)	Change in LDL-C (%)
Vehicle	-	+5%
PCSK9-IN-22	10	-35%
PCSK9-IN-22	30	-58%
PCSK9-IN-22	100	-72%

Visualizations

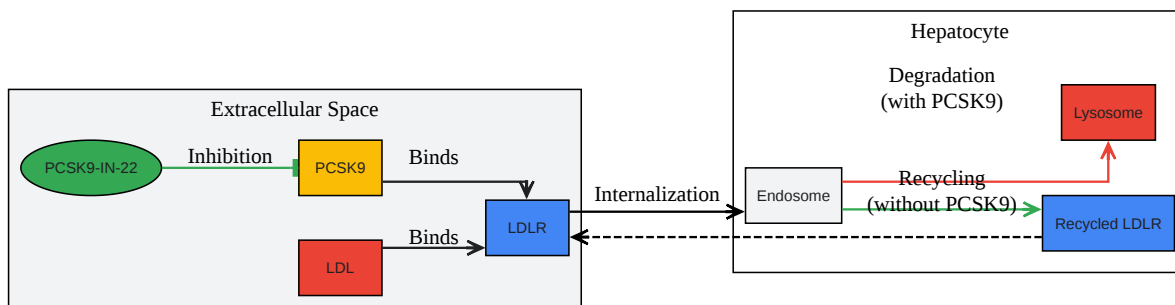

[Click to download full resolution via product page](#)

Caption: Mechanism of action of **PCSK9-IN-22** in preventing LDLR degradation.

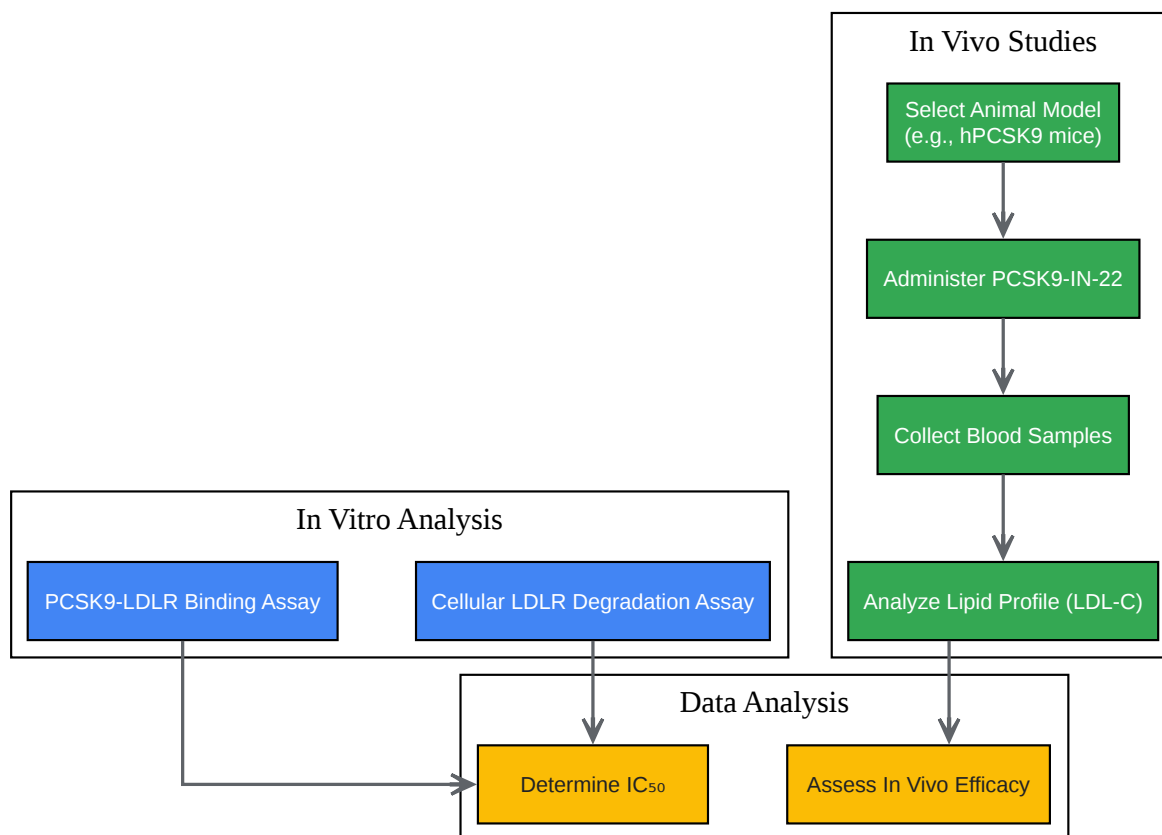

[Click to download full resolution via product page](#)

Caption: General experimental workflow for characterizing **PCSK9-IN-22**.

Need Custom Synthesis?

BenchChem offers custom synthesis for rare earth carbides and specific isotopic labeling.

Email: info@benchchem.com or [Request Quote Online](#).

References

- 1. droracle.ai [droracle.ai]
- 2. [PCSK9 Inhibitors - StatPearls - NCBI Bookshelf](https://pubmed.ncbi.nlm.nih.gov/) [ncbi.nlm.nih.gov]

- [3. researchgate.net \[researchgate.net\]](#)
- [4. A bibliometric analysis of PCSK9 inhibitors from 2007 to 2022 - PMC \[pmc.ncbi.nlm.nih.gov\]](#)
- [5. Current Evidence and Future Directions of PCSK9 Inhibition | USC Journal Current Evidence and Future Directions of PSCK9 Inhibition \[uscjournal.com\]](#)
- [6. google.com \[google.com\]](#)
- [7. PCSK9 inhibition to reduce cardiovascular disease risk: recent findings from the biology of PCSK9 - PMC \[pmc.ncbi.nlm.nih.gov\]](#)
- [8. PCSK9 Inhibition: From Current Advances to Evolving Future - PMC \[pmc.ncbi.nlm.nih.gov\]](#)
- To cite this document: BenchChem. [Refining experimental protocols for PCSK9-IN-22]. BenchChem, [2026]. [Online PDF]. Available at: [\[https://www.benchchem.com/product/b12377129/docs#refining-experimental-protocols-for-pcsk9-in-22\]](https://www.benchchem.com/product/b12377129/docs#refining-experimental-protocols-for-pcsk9-in-22)

Disclaimer & Data Validity:

The information provided in this document is for Research Use Only (RUO) and is strictly not intended for diagnostic or therapeutic procedures. While BenchChem strives to provide accurate protocols, we make no warranties, express or implied, regarding the fitness of this product for every specific experimental setup.

Technical Support: The protocols provided are for reference purposes. Unsure if this reagent suits your experiment?

Need Industrial/Bulk Grade? [Request Custom Synthesis Quote](#)

BenchChem

Our mission is to be the trusted global source of essential and advanced chemicals, empowering scientists and researchers to drive progress in science and industry.

Contact

Address: 3281 E Guasti Rd

Ontario, CA 91761, United States

Phone: (601) 213-4426

Email: info@benchchem.com

Contact our Ph.D. Support Team for a compatibility check