

# Navigating Infigratinib Resistance: A Comparative Guide for Researchers

**Author:** BenchChem Technical Support Team. **Date:** April 2026

## Compound of Interest

Compound Name: *Infigratinib-d3*

Cat. No.: *B12377363*

[Get Quote](#)

For researchers, scientists, and drug development professionals, this guide provides an objective comparison of the mechanisms underlying resistance to infigratinib, a selective FGFR inhibitor. Supported by experimental data, this document outlines the key on-target and off-target alterations that limit the efficacy of this therapy, offering insights for the development of next-generation strategies to overcome resistance.

Infigratinib has shown clinical activity in patients with tumors harboring FGFR2 fusions, particularly in cholangiocarcinoma.[1] However, as with many targeted therapies, the development of resistance is a significant clinical challenge, limiting the duration of response. [2] Resistance to infigratinib is broadly categorized into two main types: on-target mechanisms, which involve alterations to the FGFR protein itself, and off-target mechanisms, which activate alternative signaling pathways to bypass the FGFR blockade.

## On-Target Resistance: The Gatekeeper's Role

The most common on-target mechanism of resistance to infigratinib involves the acquisition of secondary mutations in the kinase domain of FGFR2.[3] These mutations can sterically hinder the binding of infigratinib to the ATP-binding pocket or alter the conformation of the kinase domain, reducing the drug's inhibitory activity.

Among these, "gatekeeper" mutations are a frequent cause of resistance to many tyrosine kinase inhibitors.[4] In the context of FGFR2, the valine at position 564 (V564) is a key gatekeeper residue.[4] Mutations at this site, such as V564F, can confer resistance to infogratinib.[4]

## Comparative Efficacy of FGFR Inhibitors Against Gatekeeper Mutations

The development of next-generation FGFR inhibitors aims to overcome the challenge of gatekeeper mutations. The following table summarizes the half-maximal inhibitory concentrations (IC50) of infogratinib and other FGFR inhibitors against wild-type and mutant FGFR2, providing a quantitative comparison of their efficacy.

FGFR2 Status	Infogratinib IC50 (nM)	Pemigatinib IC50 (nM)	Erdafitinib IC50 (nM)	Futibatinib IC50 (nM)
Wild-type	0.9	0.2	1.2	0.43
V564F (Gatekeeper)	>1000	15.7	11.5	>1000
N549H	Resistant	-	-	-
N549K	Resistant	-	-	-
E565A	490.91	-	-	-
L617M	2296.15	-	-	-

Data compiled from multiple sources.[2][4] Note: "-" indicates data not available in the searched literature.

## Off-Target Resistance: Bypassing the Blockade

Cancer cells can also develop resistance to infogratinib by activating alternative signaling pathways, thereby circumventing their dependence on FGFR signaling. This "bypass signaling" is a common mechanism of resistance to targeted therapies. The two most prominent bypass pathways implicated in infogratinib resistance are the MAPK and PI3K/AKT pathways.

## Activation of Bypass Signaling Pathways

Upon prolonged exposure to infigratinib, some cancer cells upregulate the phosphorylation of key downstream effectors in the MAPK and PI3K/AKT pathways, such as ERK and AKT, respectively. This reactivation of downstream signaling can restore cell proliferation and survival despite the continued inhibition of FGFR.

Resistance Mechanism	Protein Analyzed	Fold Change in Activation (Resistant vs. Sensitive)
MAPK Pathway Activation	p-ERK	> 2-fold increase
PI3K/AKT Pathway Activation	p-AKT	> 2-fold increase

Note: The fold changes are generalized from multiple studies indicating significant upregulation. Specific quantification can vary depending on the cell line and experimental conditions.[\[5\]](#)[\[6\]](#)

## Visualizing Resistance Mechanisms

To better understand the complex interplay of these resistance mechanisms, the following diagrams illustrate the key signaling pathways, a typical experimental workflow for studying resistance, and the logical relationship between on-target and off-target resistance.

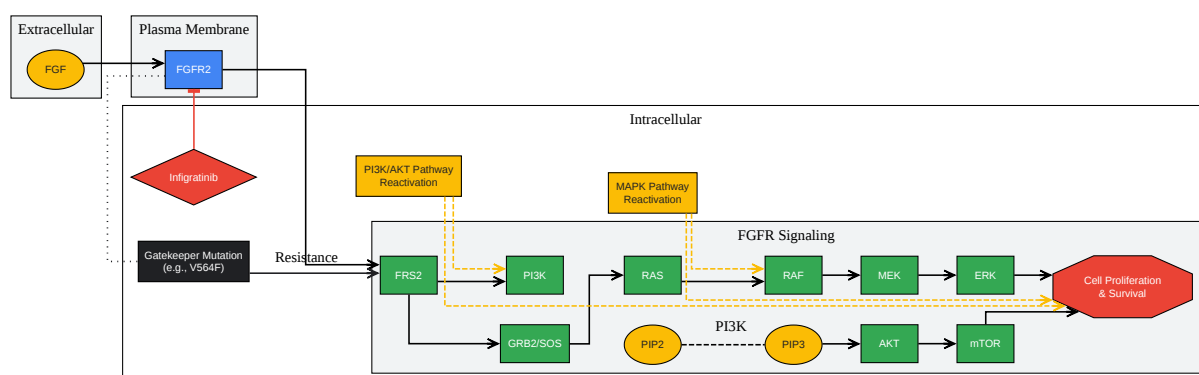

[Click to download full resolution via product page](#)

Caption: Infigratinib resistance signaling pathways.

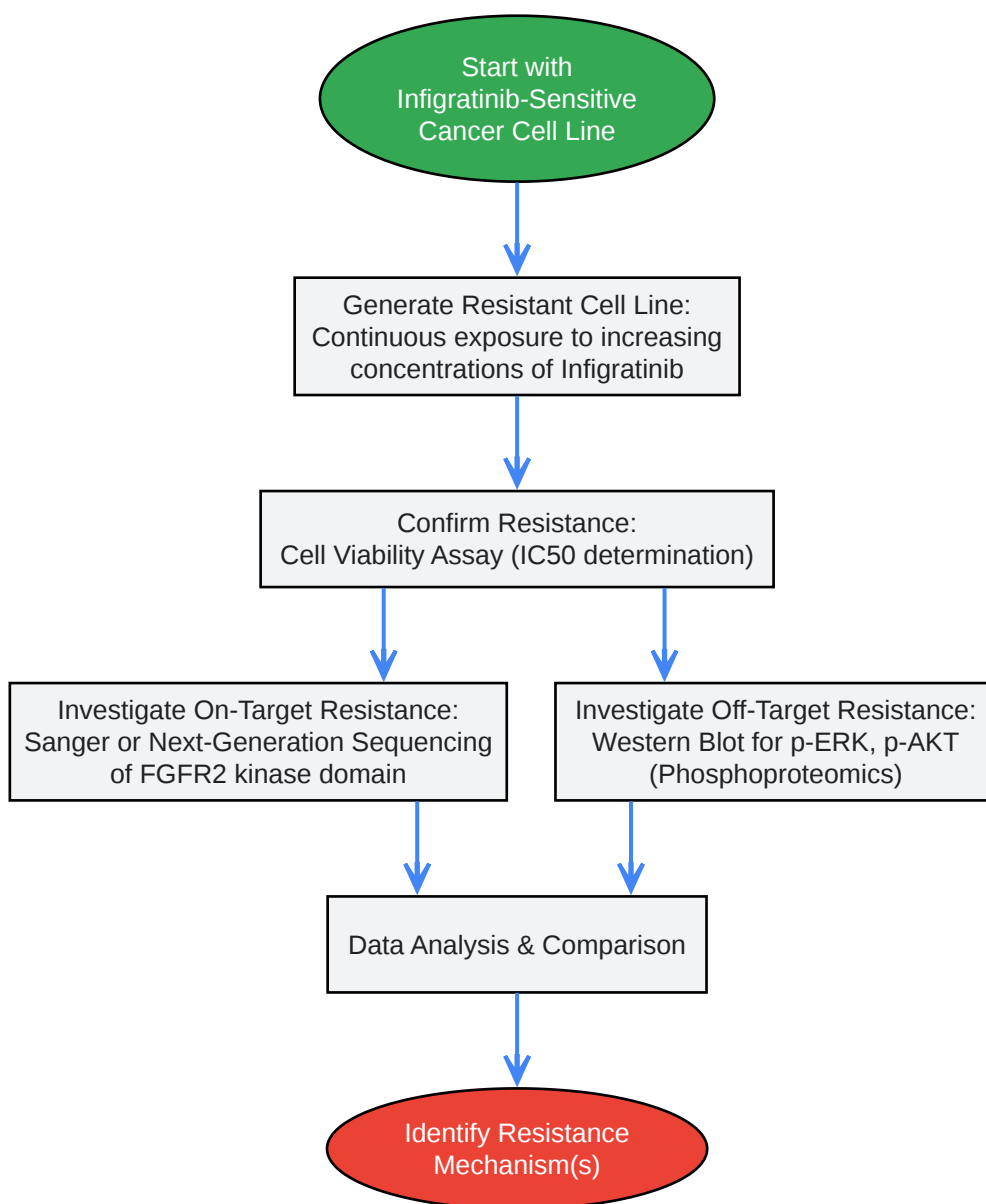

[Click to download full resolution via product page](#)

Caption: Experimental workflow for studying infigratinib resistance.

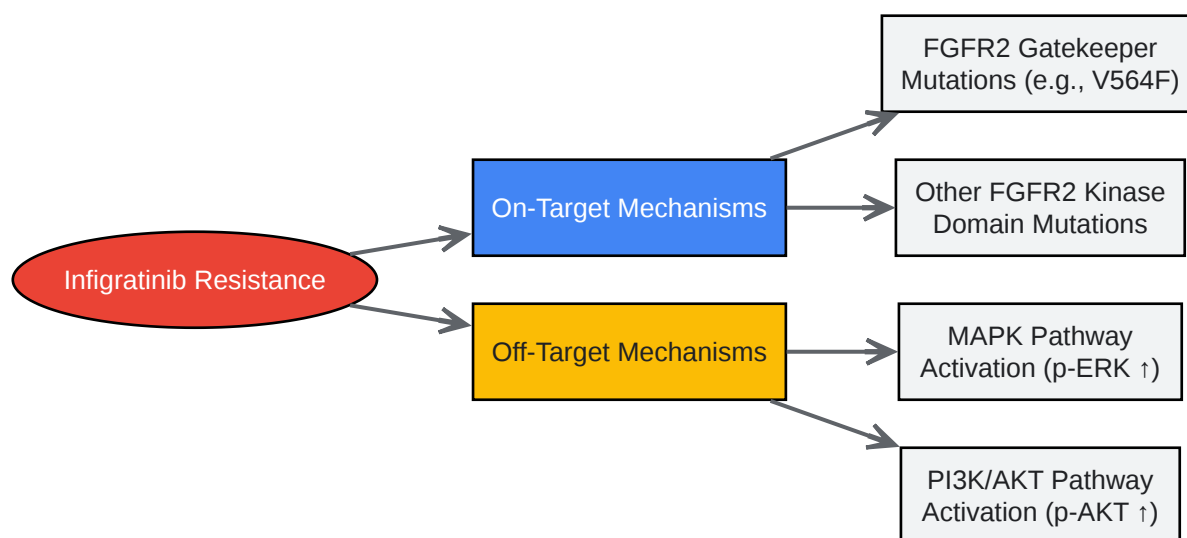

[Click to download full resolution via product page](#)

Caption: Logical relationships of infigratinib resistance mechanisms.

## Experimental Protocols

This section provides an overview of the key experimental methodologies used to investigate infigratinib resistance.

### Generation of Infigratinib-Resistant Cell Lines

- Cell Culture: Start with a parental cancer cell line known to be sensitive to infigratinib (e.g., cholangiocarcinoma cell lines with an FGFR2 fusion).
- Initial Drug Exposure: Treat the cells with infigratinib at a concentration equal to the IC50 value.
- Dose Escalation: Once the cells have adapted and are proliferating steadily, gradually increase the concentration of infigratinib in the culture medium. This is typically done in a stepwise manner, increasing the dose by 1.5- to 2-fold at each step.[7]
- Selection and Expansion: At each concentration, a sub-population of resistant cells will survive and proliferate. These cells are then expanded and used for the next round of dose escalation.

- **Confirmation of Resistance:** After several months of continuous culture with escalating doses of infigratinib, the resistance of the resulting cell line is confirmed by performing a cell viability assay and determining the new, higher IC50 value compared to the parental cell line. [8][9]
- **Clonal Selection:** To ensure a homogenous population, single-cell cloning can be performed by limiting dilution in 96-well plates.[10][11]

## Cell Viability Assay (MTT Assay)

- **Cell Seeding:** Seed cells in 96-well plates at an appropriate density and allow them to adhere overnight.
- **Drug Treatment:** Treat the cells with a serial dilution of infigratinib or other FGFR inhibitors for 72 hours.
- **MTT Addition:** Add MTT (3-(4,5-dimethylthiazol-2-yl)-2,5-diphenyltetrazolium bromide) solution to each well and incubate for 3-4 hours to allow the formation of formazan crystals.
- **Solubilization:** Add a solubilization solution (e.g., DMSO) to dissolve the formazan crystals.
- **Absorbance Measurement:** Measure the absorbance at a wavelength of 570 nm using a microplate reader.
- **IC50 Calculation:** Plot the cell viability against the drug concentration and calculate the IC50 value using a suitable software (e.g., GraphPad Prism).

## Western Blotting for Bypass Pathway Activation

- **Protein Extraction:** Lyse the sensitive and resistant cells to extract total protein.
- **Protein Quantification:** Determine the protein concentration of each lysate using a protein assay (e.g., BCA assay).
- **SDS-PAGE:** Separate the proteins by sodium dodecyl sulfate-polyacrylamide gel electrophoresis (SDS-PAGE).

- **Protein Transfer:** Transfer the separated proteins to a polyvinylidene difluoride (PVDF) membrane.
- **Blocking:** Block the membrane with a suitable blocking buffer (e.g., 5% non-fat milk or bovine serum albumin in TBST) to prevent non-specific antibody binding.
- **Primary Antibody Incubation:** Incubate the membrane with primary antibodies specific for total and phosphorylated forms of ERK and AKT overnight at 4°C.
- **Secondary Antibody Incubation:** Wash the membrane and incubate with a horseradish peroxidase (HRP)-conjugated secondary antibody.
- **Detection:** Detect the protein bands using an enhanced chemiluminescence (ECL) detection system.
- **Quantification:** Quantify the band intensities using densitometry software (e.g., ImageJ) and normalize the phosphorylated protein levels to the total protein levels.<sup>[5][6][12]</sup>

## Conclusion

Resistance to infogratinib is a multifaceted problem involving both on-target genetic alterations and the activation of bypass signaling pathways. A thorough understanding of these mechanisms is paramount for the development of effective strategies to overcome resistance and improve patient outcomes. This guide provides a comparative overview of the key resistance mechanisms, supported by quantitative data and experimental protocols, to aid researchers in this endeavor. Future research should focus on the development of next-generation FGFR inhibitors with activity against common resistance mutations and on the rational design of combination therapies that co-target key bypass signaling pathways.

### *Need Custom Synthesis?*

*BenchChem offers custom synthesis for rare earth carbides and specific isotopic labeling.*

*Email: [info@benchchem.com](mailto:info@benchchem.com) or [Request Quote Online](#).*

## References

- 1. [onclive.com](https://onclive.com) [onclive.com]
- 2. Targeted Therapy for Advanced or Metastatic Cholangiocarcinoma: Focus on the Clinical Potential of Infigratinib - PMC [pmc.ncbi.nlm.nih.gov]
- 3. Landscape of Clinical Resistance Mechanisms to FGFR Inhibitors in FGFR2-Altered Cholangiocarcinoma - PMC [pmc.ncbi.nlm.nih.gov]
- 4. Characterization of the cholangiocarcinoma drug pemigatinib against FGFR gatekeeper mutants - PMC [pmc.ncbi.nlm.nih.gov]
- 5. Convergent MAPK Pathway Alterations Mediate Acquired Resistance to FGFR Inhibitors in Cholangiocarcinoma with FGFR Fusions - PMC [pmc.ncbi.nlm.nih.gov]
- 6. Combined FGFR and Akt pathway inhibition abrogates growth of FGFR1 overexpressing EGFR-TKI-resistant NSCLC cells - PMC [pmc.ncbi.nlm.nih.gov]
- 7. Development of Drug-resistant Cell Lines for Experimental Procedures - PMC [pmc.ncbi.nlm.nih.gov]
- 8. Protocol to identify small-molecule inhibitors against cancer drug resistance - PMC [pmc.ncbi.nlm.nih.gov]
- 9. [researchgate.net](https://researchgate.net) [researchgate.net]
- 10. [knowledge.lonza.com](https://knowledge.lonza.com) [knowledge.lonza.com]
- 11. [youtube.com](https://youtube.com) [youtube.com]
- 12. [researchgate.net](https://researchgate.net) [researchgate.net]
- To cite this document: BenchChem. [Navigating Infigratinib Resistance: A Comparative Guide for Researchers]. BenchChem, [2026]. [Online PDF]. Available at: [https://www.benchchem.com/product/b12377363/docs#navigating-infigratinib-resistance-a-comparative-guide-for-researchers]

---

### Disclaimer & Data Validity:

The information provided in this document is for Research Use Only (RUO) and is strictly not intended for diagnostic or therapeutic procedures. While BenchChem strives to provide accurate protocols, we make no warranties, express or implied, regarding the fitness of this product for every specific experimental setup.

**Technical Support:** The protocols provided are for reference purposes. Unsure if this reagent suits your experiment?

**Need Industrial/Bulk Grade?** [Request Custom Synthesis Quote](#)

## BenchChem

Our mission is to be the trusted global source of essential and advanced chemicals, empowering scientists and researchers to drive progress in science and industry.

### Contact

Address: 3281 E Guasti Rd  
Ontario, CA 91761, United States  
Phone: (601) 213-4426  
Email: [info@benchchem.com](mailto:info@benchchem.com)

[Contact our Ph.D. Support Team for a compatibility check](#)